

Features

- Defrost mode for frozen bread
- Reheat mode
- Operating voltage: 3.5~5.5V
- Few external components
- DIP-8 and SOIC-8 package

Description

The PT8A2511 is a CMOS LSI chip designed for toaster. Besides normal heating, it also provides defrost and reheat work modes. It provides low cost solution for toaster.

Applications

- Toaster

Pin Configuration

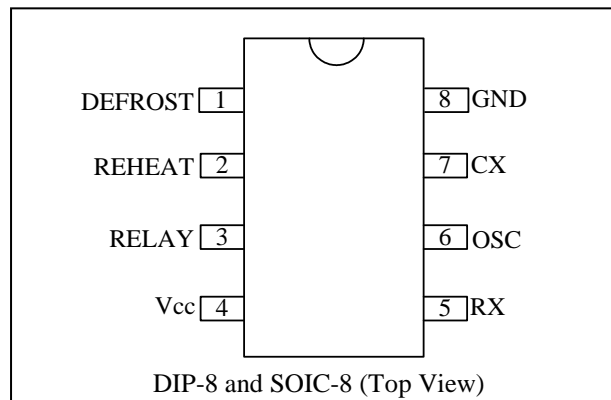

Pin Description

Name	Pin No.	Type	Description
DEFROST	1	I/O	As input, requires a negative pulse to active "Defrost" function. As output, gives a "Defrost" function indicator
REHEAT	2	I/O	As input, requires a negative pulse to active "Reheat" function. As output, gives a "Reheat" function indicator
RELAY	3	O	RELAY drive output. High active.
Vcc	4	-	Power supply
RX	5	O	Shorts to VCC once an active negative pulse appears at Reheat
OSC	6	I/O	Oscillator input/output, oscillator's Frequency of 1024Hz with an external R1,C1
CX	7	O	Shorts to GND once an active negative pulse appears at Defrost
GND	8	-	Power Ground

Block Diagram

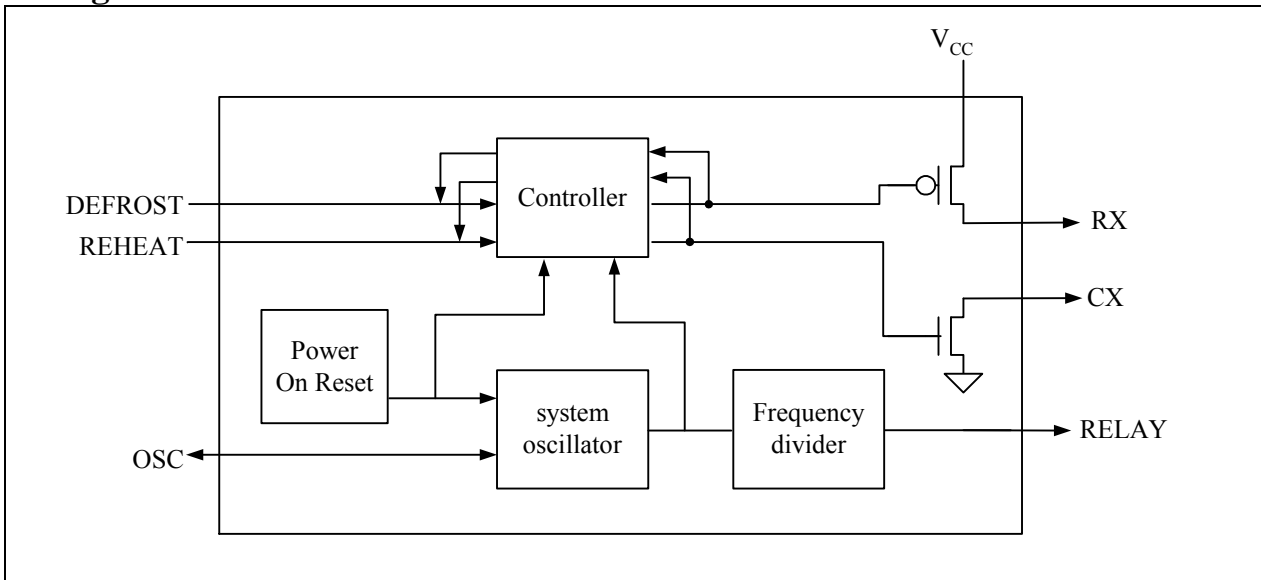

Maximum Ratings

Storage Temperature	-40°C to +125°C
Ambient Temperature with Power Applied	0 °C to +85 °C
Supply Voltage to Ground Potential (Inputs & V _{CC} Only).....	-0.5 to +5.5V
Supply Voltage to Ground Potential (Outputs & D/O Only)	-0.5 to +5.5V
DC Input Voltage.....	-0.5 to +5.5V
DC Output Current	20mA
Power Dissipation	500mW

Note:

Stresses greater than those listed under MAXIMUM RATINGS may cause permanent damage to the device. This is a stress rating only and functional operation of the device at these or any other conditions above those indicated in the operational sections of this specification is not implied. Exposure to absolute maximum rating conditions for extended periods may affect reliability.

Recommended operation conditions

Symbol	Description	Min	Type	Max	Unit
T _A	Operation Temperature	0	25	+85	°C
V _{CC}	Supply voltage	3.5	4.0	5.5	V
V _{IH}	Input High Voltage	0.8V _{CC}	-	0	V
V _{IL}	Input Low Voltage	0	-	0.35V _{CC}	V

Electrical Characteristics (T_A = 0 ~ 85 °C, unless otherwise noted)

Symbol	Description	Test Conditions		Min	Type	Max	Unit
V _{IL}	Input High Voltage	PIN: DEFROST, REHEAT	V _{CC} =4.0V	-	-	2.0	V
I _{OH}	Output Source Current	PIN: DEFROST, REHEAT	V _{CC} =3.5V V _{OH} =3.0V	-2.0	-	-	mA
I _{OL}	Output Sink Current	PIN: DEFROST, REHEAT	V _{CC} =3.5V V _{OL} =0.5V	4	-	-	mA
I _{OH}	Output Source Current	PIN: RELAY	V _{CC} =3.5V V _{OH} =2.0V	-15	-	-	mA
I _{OL}	Output Sink Current	PIN: RELAY	V _{CC} =3.5V V _{OL} =0.5V	0.5	-	-	mA
I _{IH}	Input High Leakage Current	-	V _{CC} =4.0V V _{IH} =3.5V	-	-	-1	µA
I _{IL}	Input Low Leakage Current	-	V _{CC} =4.0V V _{IL} =0.5V	-	-	1	µA
OSC	Frequency of normal oscillator	V _{CC} =4.0V, R1=56kΩ, C1=223		952	1024	1096	Hz
I _{CC}	Power supply Current	V _{CC} =4.0V, R1=56kΩ, C1=223, all output floating		-	-	100	µA

Application Circuit

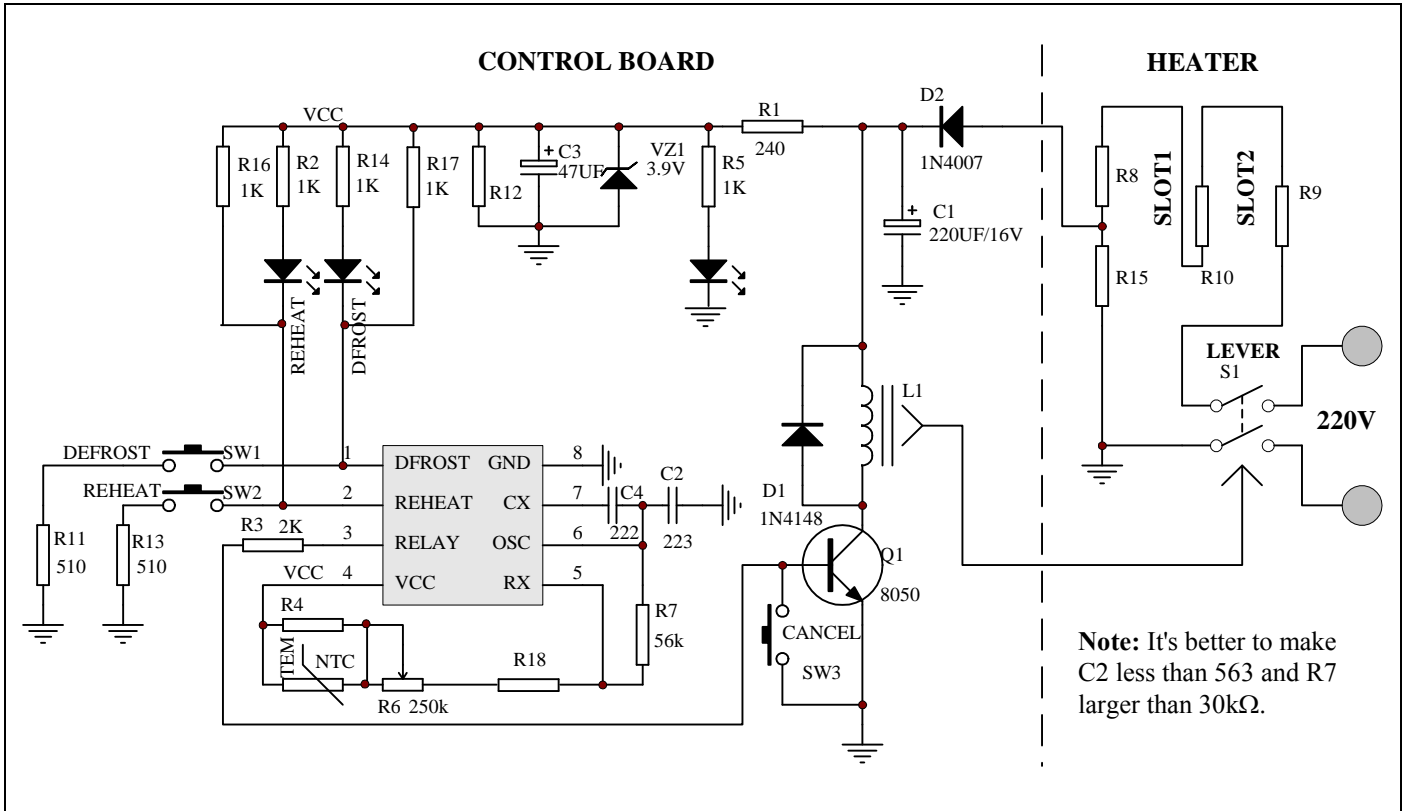

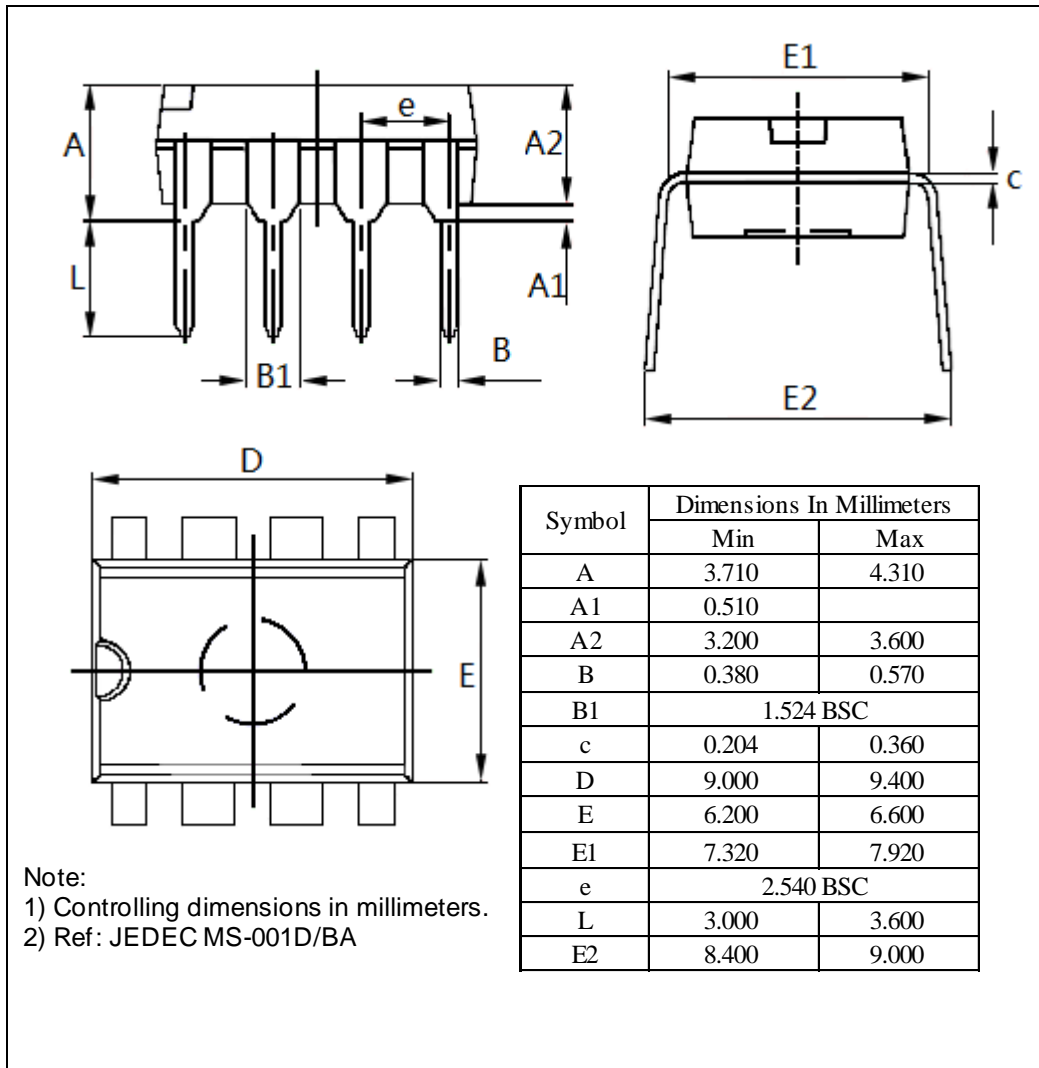
Mechanical Information
PE (DIP-8)

WE (SOIC-8)

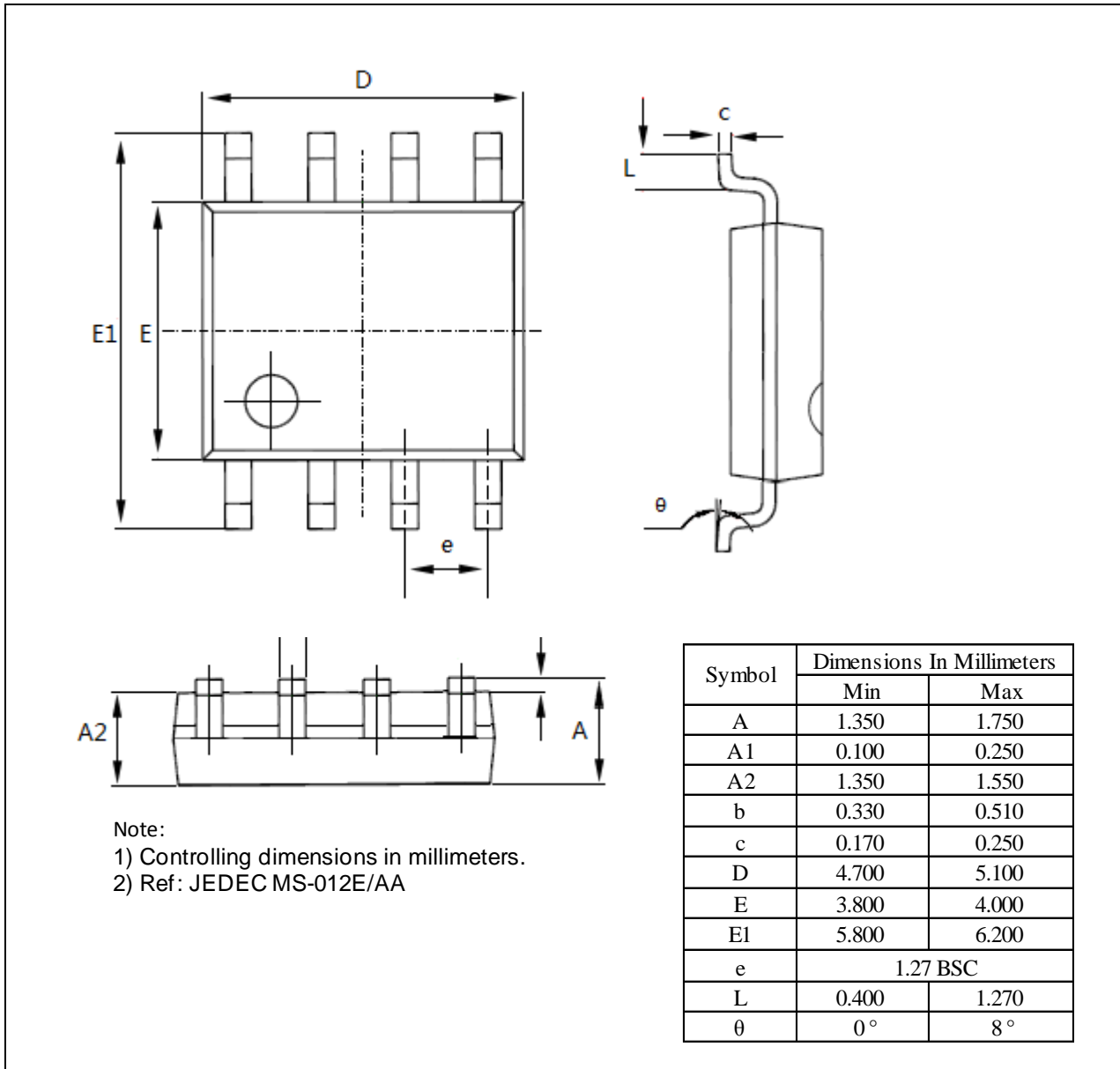

Ordering Information

Part No.	Package Code	Package
PT8A2511PE	P	Lead free 8-pin DIP
PT8A2511WE	W	Lead free and Green 8-pin SOIC

Note:

- E = Pb-free or Pb-free and Green
- Adding X Suffix= Tape/Reel

Pericom Semiconductor Corporation • 1-800-435-2336 • www.pericom.com

Pericom Technology Incorporation reserves the right to make changes to its products or specifications at any time, without notice, in order to improve design or performance and to supply the best possible product. Pericom Technology does not assume any responsibility for use of any circuitry described other than the circuitry embodied in Pericom Technology product. The company makes no representations that circuitry described herein is free from patent infringement or other rights, of Pericom Technology Incorporation.

X-ON Electronics

Largest Supplier of Electrical and Electronic Components

Click to view similar products for [Timers & Support Products](#) category:

Click to view products by [Diodes Incorporated](#) manufacturer:

Other Similar products are found below :

[MIC1557YD5-TR](#) [NLV14541BDG](#) [PT8A2515TAEX](#) [PT8A2514APE](#) [S-35710M01I-E8T3U](#) [S-35720C01A-K8T2U](#) [SY87700ALZG](#)
[Z84C3006PEG](#) [SA555S-13](#) [SE556J](#) [S-1410H30-K8T2U4](#) [S-35710C01I-K8T2U](#) [S-35720C01I-K8T2U](#) [S-35720C02I-K8T2U](#) [S-35730C01I-](#)
[K8T2U](#) [S-35740C01I-K8T2U](#) [S-1410G29-K8T2U4](#) [S-1410A28-K8T2U4](#) [S-1410I45-K8T2U4](#) [ALD555PAL](#) [ALD7555PAL](#) [AD807A-](#)
[155BRZ](#) [AD808-622BRZ](#) [ADN2807ACPZ](#) [ADN2819ACPZ-CML](#) [SE555QS-13](#) [ZSCT1555N8TA](#) [XD556](#) [NJM567D](#) [NE555L-D08-T](#)
[NE555N](#) [NE555N](#) [XD555](#) [XD7555](#) [XD551](#) [LMC555N](#) [LM555N](#) [TLC555N](#) [ICM7555CD](#) [ICM7242IPAZ](#) [ICM7555IPAZ](#) [ICM7242IPA+](#)
[ICM7555IPA+](#) [ICM7556IPD+](#) [ALD2502SBL](#) [MC14541BDG](#) [ICM7556ISD+](#) [MC14541BDR2G](#) [ICM7556ISD+T](#) [ICM7240IWE+](#)