

## Features

- Operation Range: 1.6~5.5V
- 20 $\mu$ A Maximum Standby Supply Current
- Thermal and Short-Circuit Protection
- Less than 100m $\Omega$  High-side MOSFET
- Filter for key input
- 1.5A current driver
- Protection for over temperature
- Protection for over current
- Battery under-voltage indicate
- Battery over discharge protect
- Lock function
- Low cost 8-pin SOIC and 5-pin SOT23 package

## Description

The PT8A2767x is a mixed signal CMOS LSI chip designed as a simple power switch circuit for shaver, toothbrush and other electrical devices. It can drive motor directly and detect battery lacking. ON/OFF button control work status, and LED1, LED2 indicates work status. It has lock function.

## Applications

- Shaver
- Toothbrush

## Pin Configuration

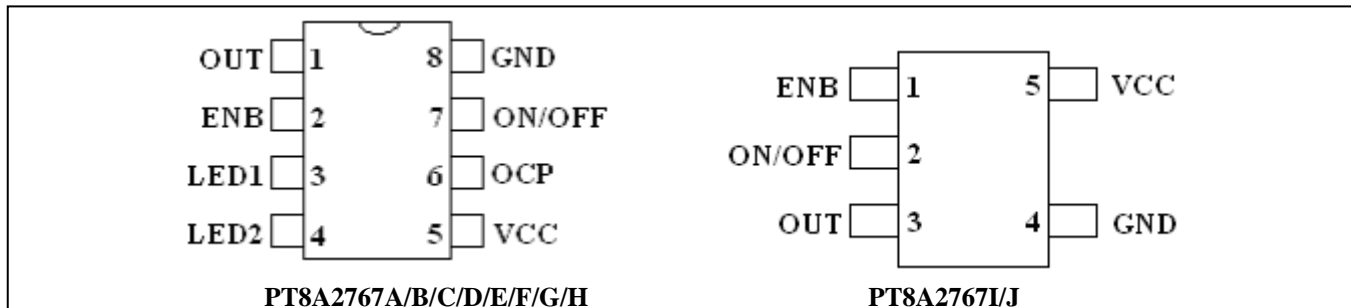

## Pin Description

### PT8A2767A/B/C/D/E/F/G/H

Pin Name	Pin No.	Type	Descriptions
OUT	1	O	Output to drive motor
ENB	2	I	Enable input, active low.
LED1	3	O	LED1 indicator output.
LED2	4	O	LED2 indicator output.
VCC	5	Power	Power supply.
OCF	6	I	Over current protection input
ON/OFF	7	I	Key input, active low; this pin can also adjust the protection voltage of battery discharge.
GND	8	Power	Ground.

### PT8A2767I/J

Pin Name	Pin No.	Type	Descriptions
ENB	1	I	Enable input, active low.
ON/OFF	2	I	Key input, active low; this pin can also adjust the protection voltage of battery discharge.
OUT	3	O	Output to drive motor
GND	4	Power	Ground.
VCC	5	Power	Power supply.

## Block Diagram

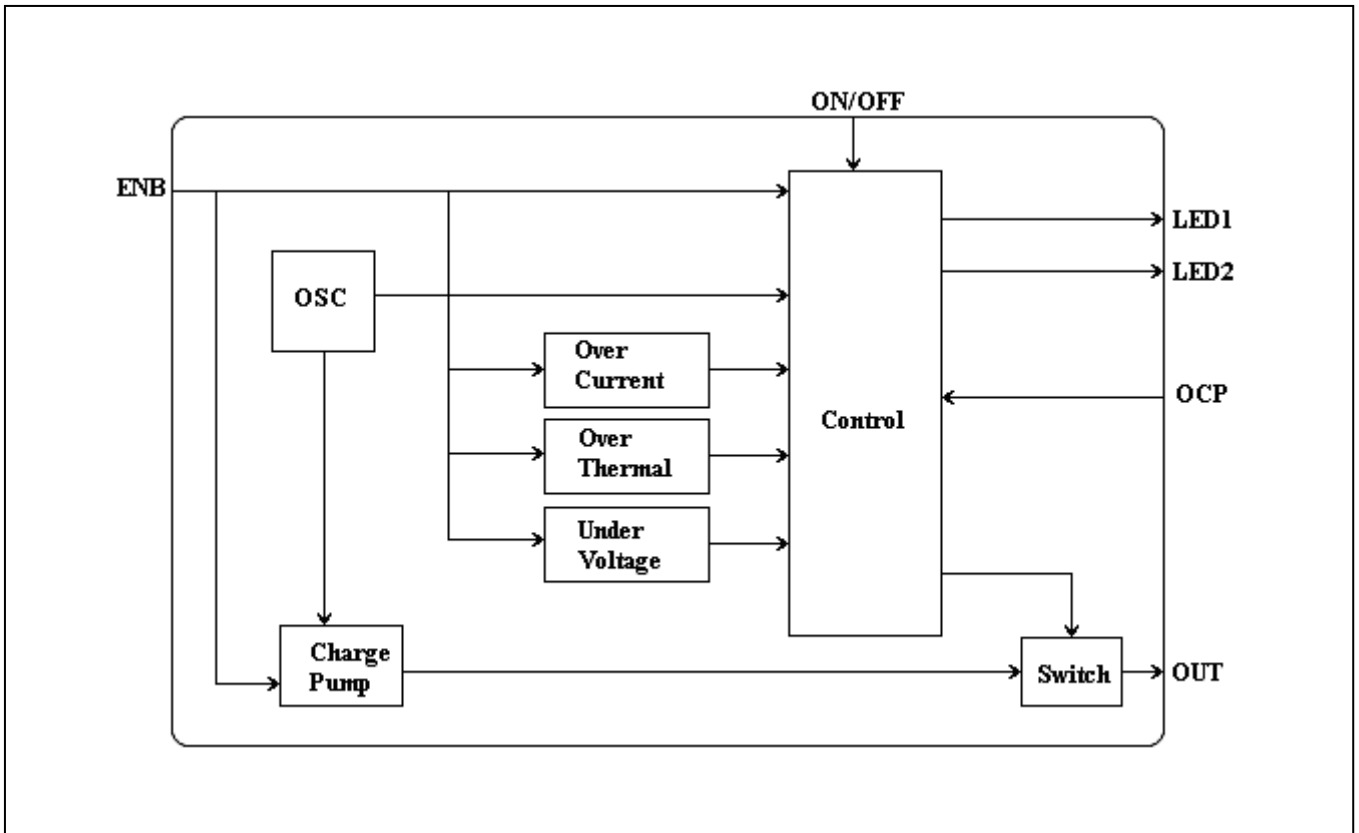

## Maximum Ratings

Storage Temperature.....	-40°C to +125°C
Supply Voltage to Ground Potential (Input & V <sub>CC</sub> Only).....	-0.5V to +5.5V
Supply Voltage to Ground Potential (Outputs Only).....	-0.5V to +5.5V
DC Input Voltage .....	-0.5V to +5.5V
DC Output Current.....	5A
Power Dissipation.....	1W

### Note:

Stresses greater than those listed under MAXIMUM RATINGS may cause permanent damage to the device. This is a stress rating only and functional operation of the device at these or any other conditions above those indicated in the operational sections of this specification is not implied. Exposure to absolute maximum rating conditions for extended periods may affect reliability.

## Recommended operation conditions

Symbol	Parameter	Min	Typ	Max	Unit
V <sub>CC</sub>	Operating Voltage	1.6	2.4	5.5	V
V <sub>IH</sub>	“H” Input Voltage	0.7V <sub>CC</sub>	-	-	V
V <sub>IL</sub>	“L” Input Voltage	-	-	0.3 V <sub>CC</sub>	V
T <sub>A</sub>	Operating temperature	0	25	85	°C

## Electrical Characteristics

( $T_A = 0 \sim 85^\circ\text{C}$ , unless otherwise noted)

Symbol	Parameter	Test Conditions		Min	Typ	Max	Unit
		V <sub>CC</sub>	Conditions				
I <sub>CCQ</sub>	Standby current	2.4V	Floating	-	-	20.	μA
I <sub>OUT</sub>	OUT output current	2.4V	T <sub>aul</sub> =50mS	-5.0	-	-	A
		2.4V	V <sub>OUT</sub> =0.15V	-1.5	-	-	A
VT1	Battery lacking	-	No pull low resistor in Pin: ON/OFF	2.1	2.2	2.3	V
VT2	Battery over discharge	-	No pull low resistor in Pin: ON/OFF. Auto off	1.8	1.9	2.0	V
VT3	Over Current Protect	2.4V	Pin: OCP	2.22	2.25	2.28	V
VT4	ON/OFF Trigger Voltage		Pin: ON/OFF	0.3	0.8	1.1	V
T1	Short click button	-	Pin: ON/OFF	40	70	90	mS
T2	Long click button	-	Pin: ON/OFF	2.8	3.4	4.1	S
T3	Over current protection	-	V <sub>OCP</sub> <VT3	2.0	3.0	4.0	S
T4	Over temperature protection	-	-	130	-	-	°C
Rth(j-a)	Junction to ambient (DC)		SOIC-8 package	-	42	-	°C/W
			SOT23-5 package	-	86	-	

## Functional Description

- ON/OFF Button**

The button will be toggled ON or OFF state by pushing it less than 3 seconds, and toggling lock or unlock state by pushing it over 3 seconds. Description is as below:

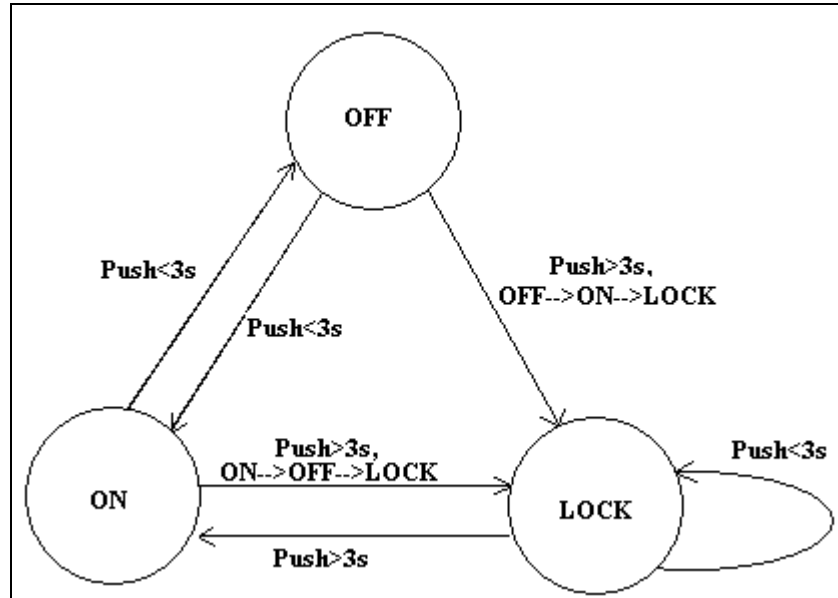

- LED Indicator**

LED1, LED2 work status is as below:

Work Status		Mode1		Mode2	
		LED1	LED2	LED1	LED2
Off		Off	Off	Off	Off
On	Normal	On	Off	On	Off
	Under voltage	Off	On	Flash1 *	Off
Lock	Normal	Flash2*	Off	Off	Flash2*
	Under voltage	Off	Flash2*	Off	Flash2*

**Note:** 1. Flash1: LED flashes by 1.5Hz;  
2. Flash2: LED flashes by 1.5Hz, but only 5 times.

- Reset**

After power on, the chip will be reset by internal POR circuit. LED1 and LED2 pin will output low level and OUT pin will output high-impedance state.

- Over Current Protect**

When Output current from pin OUT is over spec, the IC will turn to OFF state.

- Over Temperature Protect**

When IC junction temperature is over spec, pin OUT will turn to high-impedance state and the system is still in ON State.

- Battery Over Discharge Protect**

During on state, the IC will auto off when the battery voltage is under spec (VT2). If the process repeats three times continuously, the IC will be always in off state and ON/OFF button will be locked unless reset pin ENB.

- Under Voltage Protection**

During on state, the IC will turn to under voltage mode when the battery voltage is under spec (VT1).

**Application Circuit**

PT8A2767A/B/C/D/E/F/G/H

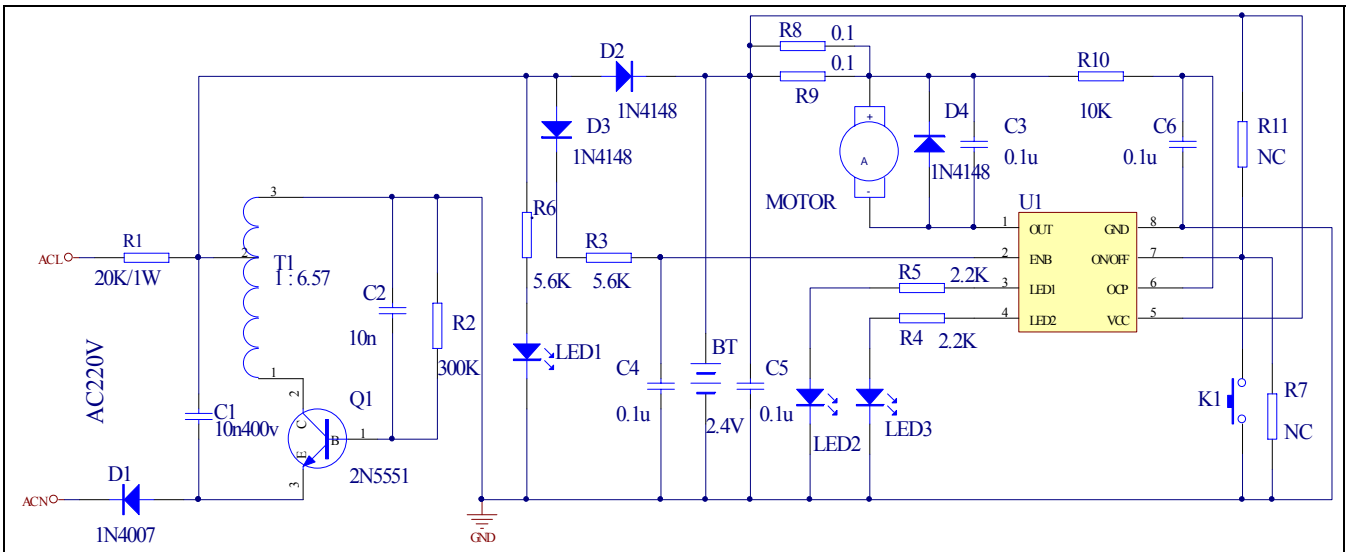

PT8A2767I/J

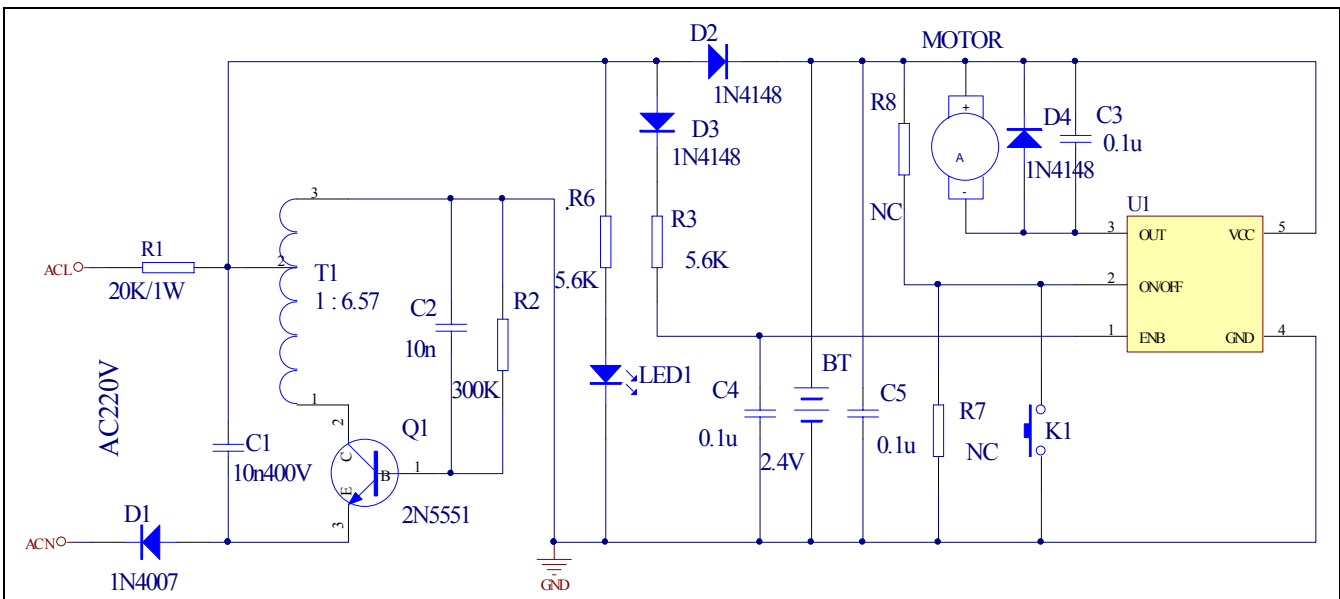

**Mechanical Information**

WE (SOIC-8)

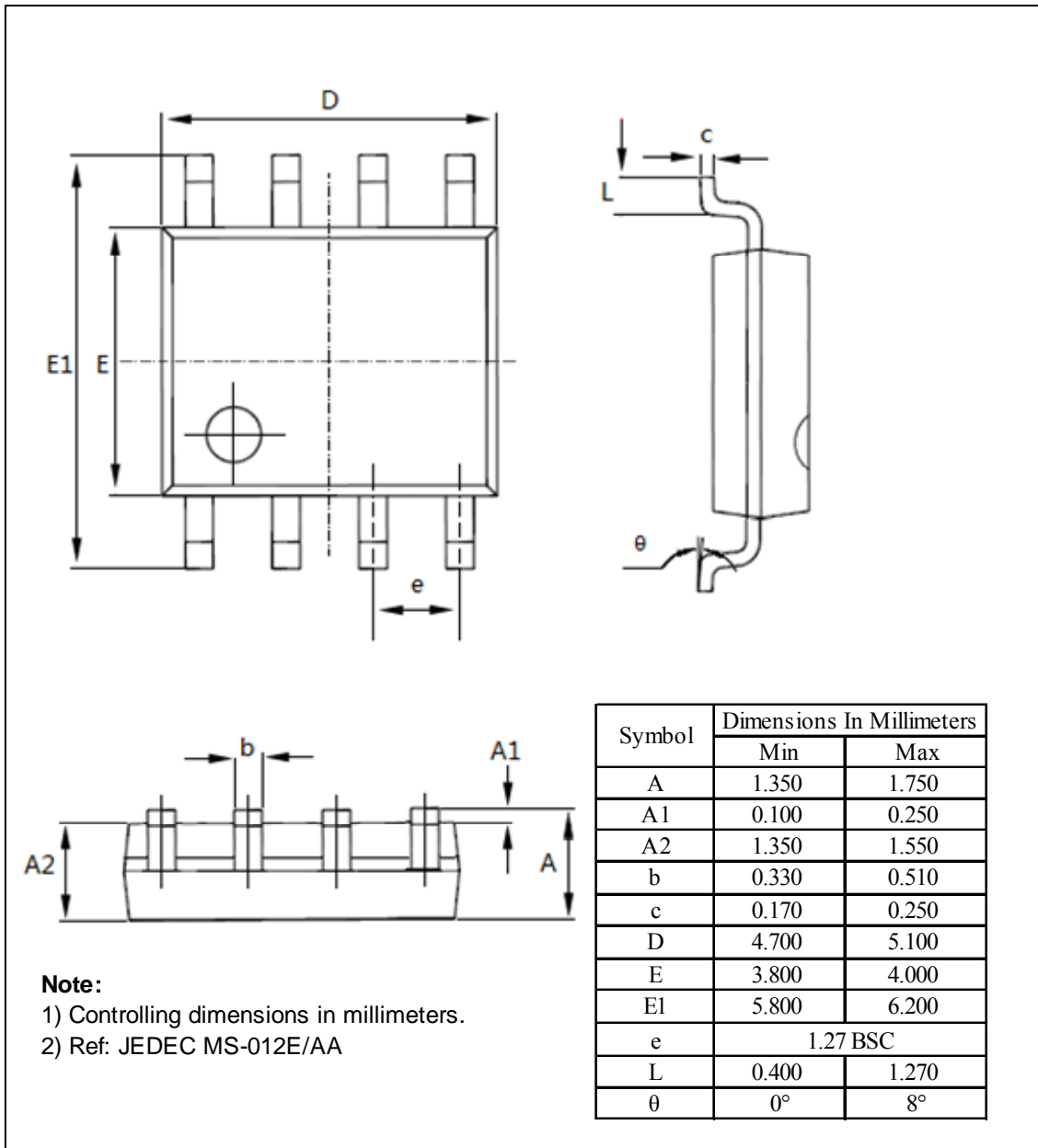

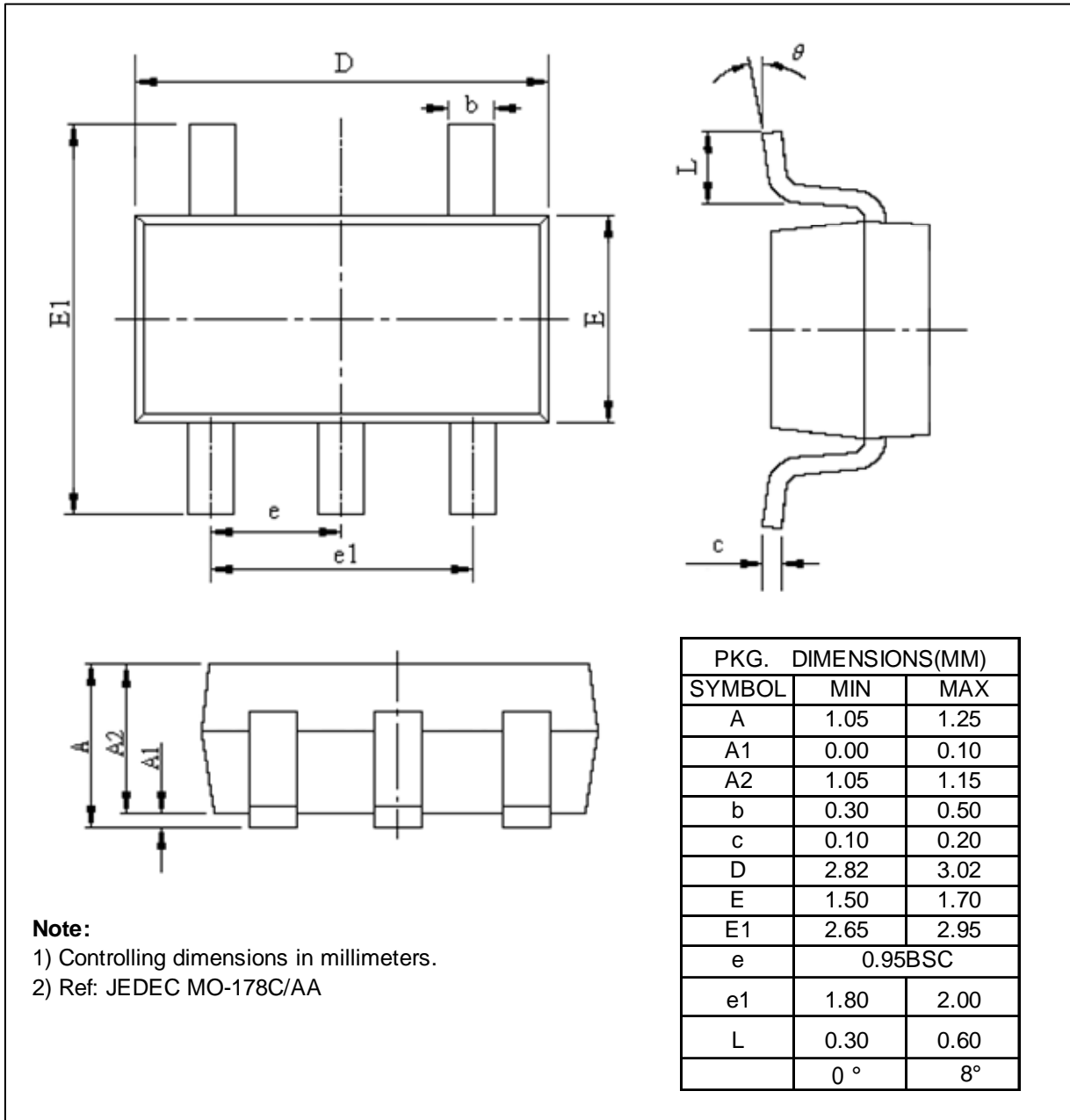
**TAE (SOT23-5L)**

### Ordering Information

Part No.	Package Code	Package
PT8A2767xWE	W	Lead free and Green 8-Pin SOIC
PT8A2767ITAE*	TA	Lead free and Green 5-Pin SOT23
PT8A2767JTAE*	TA	Lead free and Green 5-Pin SOT23

**Note:**

- “x” shows A~H with different function. See *Function Comparison Table*.
- E = Pb-free and Green
- Adding X Suffix= Tape/Reel
- \*Contact Pericom for availability

### Function Comparison Table

Part No	Disable when charging	Key lock	LED flash for battery low	LED Mode	Package
PT8A2767A*	Y	N	N	1	SOIC-8
PT8A2767B*	Y	N	Y	2	SOIC-8
PT8A2767C*	Y	Y	N	1	SOIC-8
PT8A2767D*	Y	Y	Y	2	SOIC-8
PT8A2767E*	N	N	N	1	SOIC-8
PT8A2767F	N	N	Y	2	SOIC-8
PT8A2767G*	N	Y	N	1	SOIC-8
PT8A2767H*	N	Y	Y	2	SOIC-8
PT8A2767I*	Y	N	N	1	SOT23-5
PT8A2767J*	N	N	N	1	SOT23-5

**Note:** \* Contact Pericom for availability.



## X-ON Electronics

Largest Supplier of Electrical and Electronic Components

*Click to view similar products for [Motor/Motion/Ignition Controllers & Drivers](#) category:*

*Click to view products by [Diodes Incorporated](#) manufacturer:*

Other Similar products are found below :

[FSB50550TB2](#) [FSBF15CH60BTH](#) [MSVGW45-14-2](#) [MSVGW54-14-3](#) [MSVGW54-14-5](#) [NTE7043](#) [LA6565VR-TLM-E](#) [LB11650-E](#)  
[LB1837M-TLM-E](#) [LB1845DAZ-XE](#) [LC898300XA-MH](#) [SS30-TE-L-E](#) [26700](#) [LV8281VR-TLM-H](#) [BA5839FP-E2](#) [IRAM236-1067A](#)  
[LA6584JA-AH](#) [LB11847L-E](#) [NCV70501DW002R2G](#) [STK672-630CN-E](#) [TND315S-TL-2H](#) [FNA23060](#) [FSB50250AB](#) [FNA41060](#) [MSVB54](#)  
[MSVBTC50E](#) [MSVCPM4-63-12](#) [MSVTA120](#) [FSB50550AB](#) [NCV70501DW002G](#) [LC898301XA-MH](#) [LV8413GP-TE-L-E](#) [MSVGW45-14-3](#)  
[MSVGW45-14-4](#) [MSVGW45-14-5](#) [MSVGW54-14-4](#) [STK984-091A-E](#) [SLA7026M](#) [MP6519GQ-Z](#) [LB11651-E](#) [IRSM515-025DA4](#)  
[LV8127T-TLM-H](#) [NCP81382MNTXG](#) [TDA21801](#) [LB11851FA-BH](#) [NCV70627DQ001R2G](#) [LB1938FAGEVB](#) [IGCM04G60GAXKMA1](#)  
[IKCM15H60HA](#) [TB6569FTG,8,EL](#)