



Actual Size = 7 x 5mm



### Product Features

- 5V CMOS/TTL compatible logic levels
- Pin-compatible with standard 7x5mm packages
- Designed for standard reflow and washing techniques
- Output Tri-state function
- Pb-free and RoHS/Green compliant (seam seal package only)

### Product Description

The S1700 and S1750 are 5V crystal clock oscillators. The output clock signal is compatible with CMOS/TTL logic levels. The device, available on tape and reel, is contained in a 7x5mm surface-mount ceramic package.

### Applications

The S1700 and S1750 are an ideal reference clock for SMT applications requiring 5V CMOS & TTL logic levels

- PCs, notebooks, palmtop computers
- Portable applications
- PCMCIA cards and HDD

### Packaging Outline

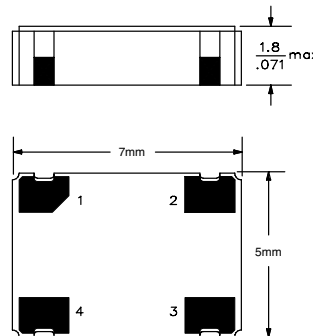

### Pin Functions

Pin	Function
1	OE Function
2	Ground
3	Clock Output
4	V <sub>DD</sub>

### Common Frequencies

Contact SaRonix for additional frequencies

3.6864 MHz	22.0000 MHz	40.0000 MHz
8.0000 MHz	24.5760 MHz	48.0000 MHz
10.0000 MHz	25.0000 MHz	50.0000 MHz
14.3181 MHz	32.0000 MHz	60.0000 MHz
16.0000 MHz	32.7680 MHz	66.0000 MHz
18.4320 MHz	33.0000 MHz	66.6667 MHz
20.0000 MHz	35.3280 MHz	75.0000 MHz

### Ordering Information

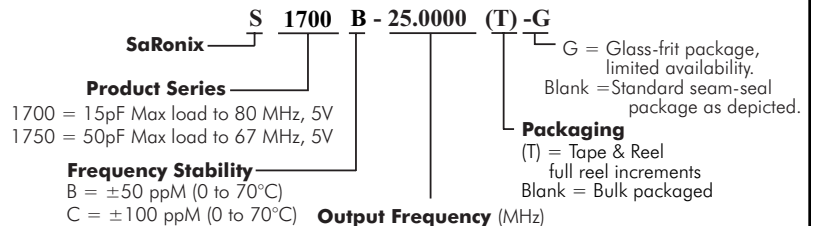

\*Note: Legacy glass frit package may continue to ship until inventory is depleted. See S1615 series to guarantee seam seal package.

### Electrical Performance

Parameter		Min.	Typ.	Max.	Units	Notes
Output frequency		1.8432		80	MHz	S1750 Max Frequency 67 MHz
Supply voltage		+4.5	+5.0	+5.5	V DC	
Supply current, output enabled 1700				15	mA	1.8 to 35 MHz
				30		>35 to 66.0 MHz
				50		>66 to 80.0 MHz
Supply current, output enabled 1750				20	mA	1.8 to 20 MHz
				35		>20 to 50 MHz
				60		>50 to 67.0 MHz
Frequency stability				±50 to ±100	ppM	See Note 1 below
Operating temperature		0		+70	°C	
Output logic 0, VOL				10% V <sub>DD</sub>	V	HCMOS
				0.5	V	TTL, S1750 only
Output logic 1, VOH		90% V <sub>DD</sub>			V	HCMOS
		2.5			V	TTL, S1750 only
Output load				15	pF	S1700
				50	pF	S1750
				5	TTL	TTL, S1750 only
Duty cycle	CMOS	45		55	%	0 to 70°C measured 50%V <sub>DD</sub>
	TTL	40		60	%	0 to 70°C measured 1.5V, S1750 only
Rise and fall time	CMOS			10	ns	measured 20/80% of waveform
	TTL			5	ns	measured 0.5V to 2.5V, S1750 only

**Note:**  
 1. As specified. Stability includes all combinations of operating temperature, load changes, rated input (supply) voltage changes, initial calibration tolerance (25°C), aging (1 year at 25°C average effective ambient temperature), shock and vibration.

### Output Enable / Disable Function

Parameter		Min.	Typ.	Max.	Units	Notes
Input Voltage (pin 1), Output Enable (HCMOS)		90% V <sub>DD</sub>			V	or open
Input voltage (pin 1), Output Disable (HCMOS)				10% V <sub>DD</sub>	V	Output is Hi-Z
Input voltage (pin 1), Output Enable (TTL)		2.2			V	or open
Input voltage (pin 1), Output Disable (TTL)				0.8	V	Output is Hi-Z
Internal pullup resistance		50			kΩ	
Output disable delay				100	ns	
Output enable delay				100	ns	

**Absolute Maximum Ratings**

Parameter	Min.	Typ.	Max.	Units	Notes
Storage temperature	-55		+125	°C	

**Test Circuit**

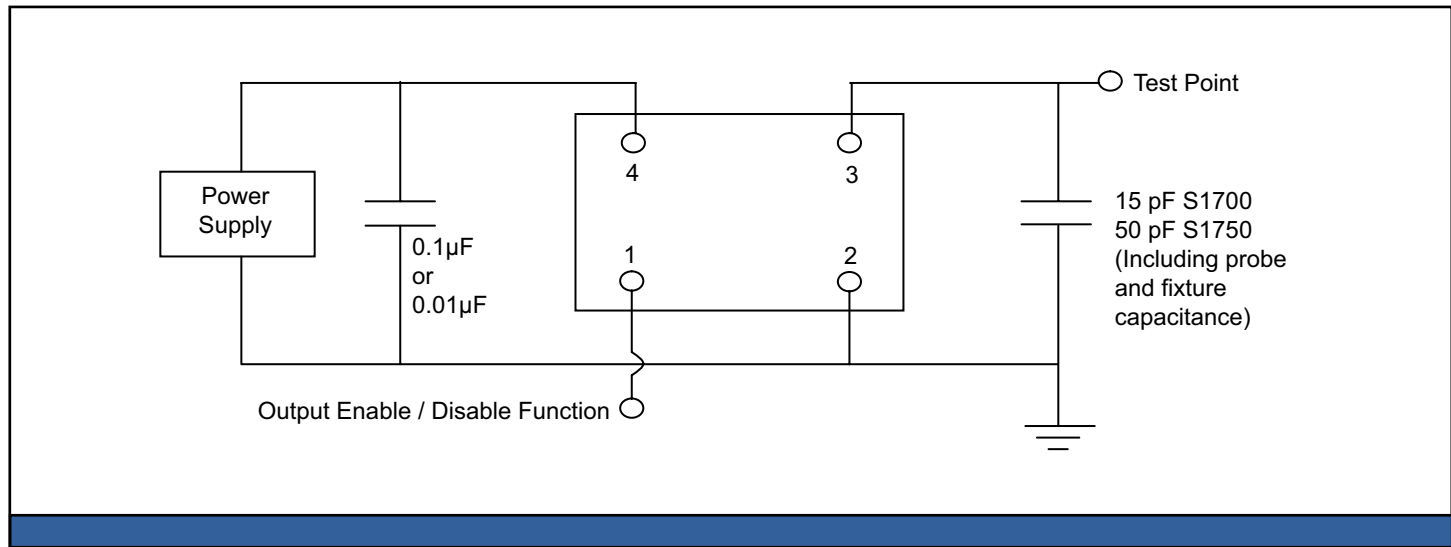

**Reliability Test Ratings**

This product is rated to meet the following test conditions (Applies to seam-seal package only):

Type	Parameter	Test Condition
Mechanical	Shock	MIL-STD-883, Method 2002, Condition B
Mechanical	Solderability	JESD22-B102-D Method 2 (Preconditioning E)
Mechanical	Terminal strength	MIL-STD-883, Method 2004, Condition D
Mechanical	Gross leak	MIL-STD-883, Method 1014, Condition C
Mechanical	Fine leak	MIL-STD-883, Method 1014, Condition A2 ( $R_1 = 2 \times 10^{-8}$ atm cc/s)
Mechanical	Solvent resistance	MIL-STD-202, Method 215
Environmental	Thermal shock	MIL-STD-883, Method 1011, Condition A
Environmental	Moisture resistance	MIL-STD-883, Method 1004
Environmental	Vibration	MIL-STD-883, Method 2007, Condition A
Environmental	Resistance to soldering heat	J-STD-020C Table 5-2 Pb-free devices (2 cycles max)

**Output Waveform**

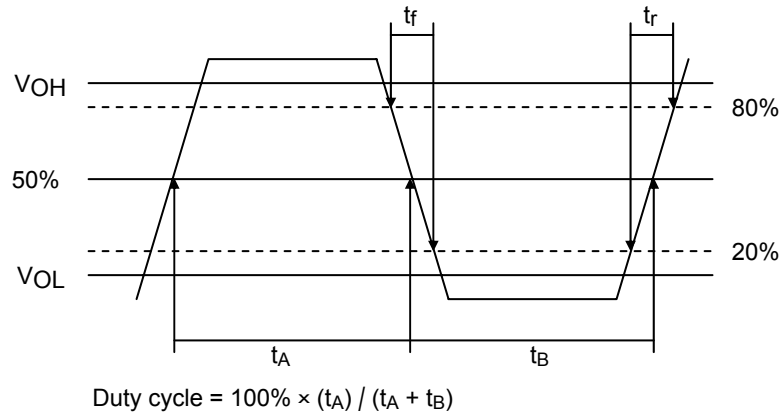

**Reflow Soldering Profile (Applies to seam-seal package only)**

As per IPC/JEDEC J-STD-020C

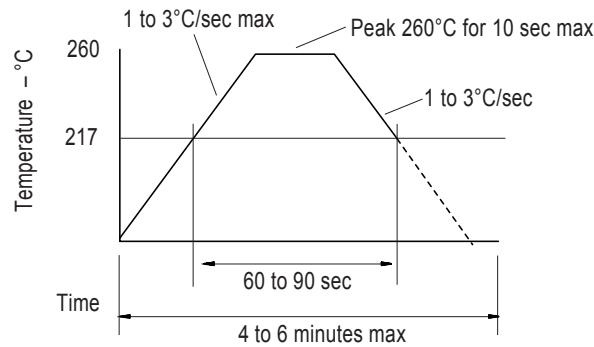

**Mechanical Drawings**

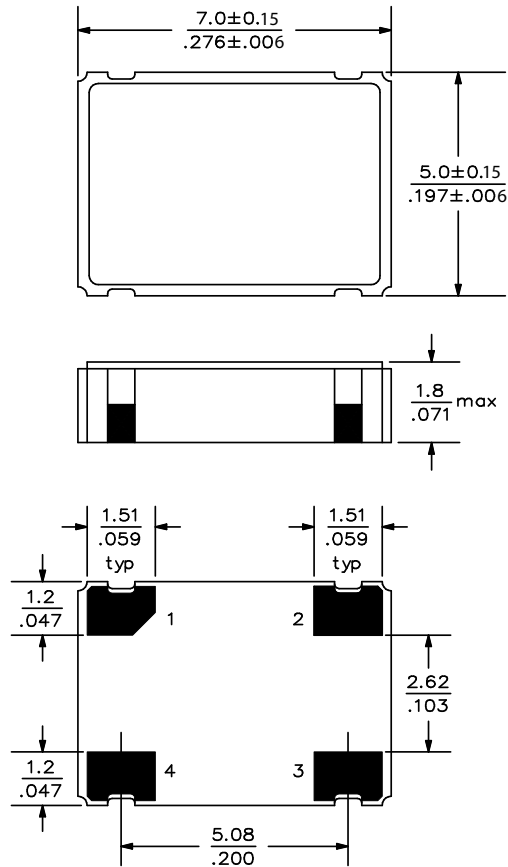

**Note:** Seam-seal package is depicted. Legacy glass-frit package has limited availability, please inquire if needed.

**Recommended Land Pattern\***

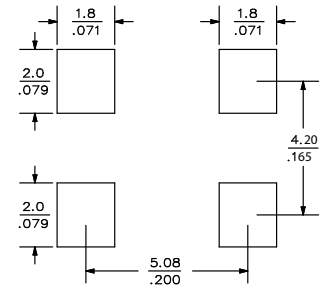

\*External high-frequency power decoupling is recommended. (see test circuit for minimum recommendation). To ensure optimal performance, do not route traces beneath the package.

Scale: None. Dimensions are in mm/inches.

**Marking LINE 1:** S XX YY WW X (SaRonix, Model, Stability, Year, Week, Origin)  
**Marking LINE 2:** • Frequency (Pin #1, Frequency code)

Note: S2YYYYWWX S1700  
S7YYYYWWX S1750

\*\*Exact location of markings may vary.

## X-ON Electronics

Largest Supplier of Electrical and Electronic Components

*Click to view similar products for [Standard Clock Oscillators](#) category:*

*Click to view products by [Diodes Incorporated](#) manufacturer:*

Other Similar products are found below :

[601252](#) [F335-12](#) [F335-25](#) [F535L-33.333](#) [F535L-50](#) [ASV-20.000MHZ-LR-T](#) [ECS-2018-160-BN-TR](#) [EL13C7-H2F-125.00M](#) [MXO45HS-2C-66.6666MHZ](#) [SiT8209AI-32-33E-125.000000](#) [SM4420TEV-40.0M-T1K](#) [F335-24](#) [F335-40](#) [F535L-10](#) [F535L-16](#) [F535L-24](#) [F535L-27](#) [F535L-48](#) [PE7744DW-100.0M](#) [CSX-750FCC14745600T](#) [ASF1-3.686MHZ-N-K-S](#) [XO57CTECNA3M6864](#) [ECS-2100A-147.4](#) [601251](#) [EP16E7E2H26.000MTR](#) [SIT8918AA-11-33S-16.000000G](#) [XO3003](#) [9120AC-2D2-33E212.500000](#) [9102AI-243N25E100.00000](#) [8208AC-82-18E-25.00000](#) [ASDK2-32.768KHZ-LR-T3](#) [8008AI-72-XXE-24.545454E](#) [8004AC-13-33E-133.33000X](#) [AS-4.9152-16-SMD-TR](#) [ASFL1-48.000MHZ-LC-T](#) [SIT8920AM-31-33E-25.0000](#) [DSC1028DI2-019.2000](#) [9121AC-2C3-25E100.00000](#) [9102AI-233N33E100.00000X](#) [9102AI-233N25E200.00000](#) [9102AI-232H25S125.00000](#) [9102AI-133N25E200.00000](#) [9102AC-283N25E200.00000](#) [9001AC-33-33E1-30.000](#) [3921AI-2CF-33NZ125.000000](#) [5730-1SF](#) [PXA000010](#) [SIT1602BC-83-33E-10.000000Y](#) [8003AI-12-33S-40.00000Y](#) [1602BI-13-33S-19.200000E](#)