

DIO1268

Ultra Low On-Resistance Dual, SPDT Analog Switch

Features

- Switch Type: SPDT(2X)
- Voltage Operation: 1.6V to 4.2V
- Ultra-Low On Resistance: 0.75Ω @ 4.2V
- -3dB Bandwidth: 75MHz
- High Off-isolation: -78dB@100kHz
- Low Crosstalk: -100dB@100kHz
- Excellent On Resistance Matching: 0.03Ω
- Low Total Harmonic Distortion (THD)
- Rail-to-Rail Input and Output Operation
- Break-Before-Make Switching
- Green Packaged: 10-DQFN, QFN-10
- 8kV HBM ESD

Applications

- Cell-Phone/PDA
- MP3/MP4/PMP
- Portable Instrumentation
- Battery Powered Communications
- Computer Peripherals

Descriptions

The DIO1268 is a dual Single-Pole, Double-Throw (SPDT) analog switch. DIO1268 operates from a single 1.6V to 4.2V supply and features an ultra-low on resistance of 0.75Ω at a 4.2V supply and $T_A = 25^\circ\text{C}$. This device is fabricated with sub-micron CMOS technology to achieve fast switching speeds and is designed for break-before-make operation.

DIO1268 guarantees 0.03Ω on-resistance matching between switches, on-resistance flatness over the signal range, high off-isolation and low crosstalk, which ensures excellent linearity and low distortion when switching audio signals. DIO1268 consists of two normally open and two normally close switches.

DIO1268 provides packages with Green 10-lead DQFN, 10-lead QFN.

Block Diagram

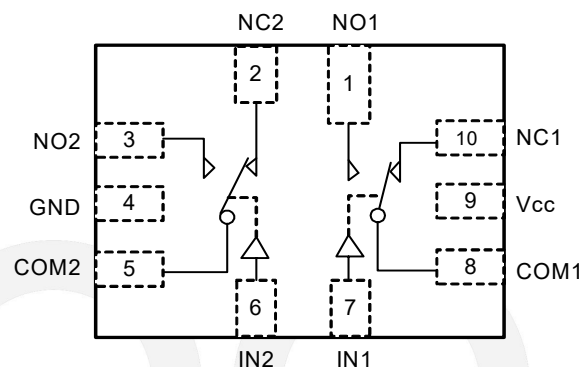

Ordering Information

Order Part Number	Top Marking		T_A	Package	
DIO1268LP10	YWGA	Green	-40 to 85°C	DQFN-10	Tape & Reel, 3000
DIO1268QN10	YWGA	Green	-40 to 85°C	QFN-10	Tape & Reel, 3000

Pin Assignment

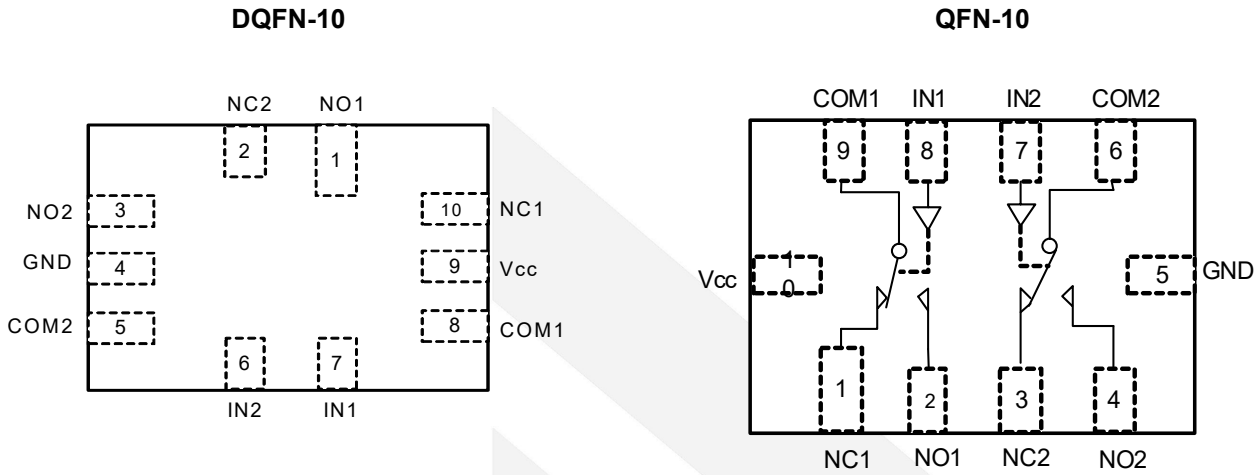

Figure 1 Top View

Pin Descriptions

Pin Name	Description
V _{cc} /GND	Power Supply
IN1, IN2	Digital control pin to connect the COM terminal to the NO or NC terminals
COM1, COM2	Common terminal
NO1, NO2	Normally-open terminal
NC1, NC2	Normally-closed terminal

Truth Table

IN1, IN2	NO	NC
L	OFF	ON
H	ON	OFF



DIO1268

Absolute Maximum Ratings

Stresses beyond those listed under “Absolute Maximum Rating” may cause permanent damage to the device. These are stress ratings only and functional operation of the device at these or any other condition beyond those indicated in the operational sections of the specifications is not implied. Exposure to absolute maximum rating conditions for extended periods may affect device reliability.

Symbol	Parameter	Min.	Max.	Unit
V_{CC}	Supply Voltage	-0.3	4.6	V
V_{CNTRL}	DC input Voltage	-0.3	$(V_{CC}) + 0.3$	V
V_{SW}	DC input I/O Voltage	-0.3	$(V_{CC}) + 0.3$	V
I_{IK}	DC input Diode current		-50	mA
T_{STG}	Storage Temperature	-65	150	°C
ESD	HBM, JEDEC: JESD22-A114		8000	V
	CDM, JEDEC : JESD22-C101		2000	

Recommend Operating Conditions

The Recommended Operating Conditions table defines the conditions for actual device operation. Recommended Operating conditions are specified to ensure optimal performance to the datasheet specifications. DIOO does not Recommend exceeding them or designing to Absolute Maximum Ratings.

Symbol	Parameter	Min.	Max.	Unit
V_{CC}	Supply voltage	1.6	4.2	V
V_{CNTRL}	Control input voltage (IN1/IN2)	0	V_{CC}	V
V_{SW}	Switch I/O voltage	0	V_{CC}	V
T_A	Operating Temperature	-40	85	°C



DIO1268

Ultra Low On-Resistance Dual, SPDT Analog Switch

Electrical Characteristics

All typical value are at $V_{CC}=4.2V$, $GND=0V$, $V_{IH}=1.5V$, $V_{IL}=0.5V$, $T_A=25^\circ C$ unless otherwise specified.

Symbol	Parameter	Conditions	V_{CC}/V	Temp	Min	Typ	Max	Unit
Analog Switch Characteristics								
R_{ON}	On-Resistance	V_{NO} , V_{NC} , or $V_{COM}=1V$, $I_{COM} = -100mA$	4.2	25°C		0.75	0.85	Ω
				-40 to 85°C			0.95	Ω
ΔR_{ON}	On-Resistance Match Between Channels	V_{NO} , V_{NC} or $V_{COM}=1V$, $I_{COM} = -100mA$	4.2	25°C		0.03	0.15	Ω
				-40 to 85°C			0.20	Ω
$R_{FLAT(ON)}$	On-Resistance Flatness	V_{NO} , V_{NC} or $V_{COM}=1V$, 2.5V $I_{COM} = -100mA$	4.2	25°C		0.15	0.23	Ω
				-40 to 85°C			0.30	Ω
$I_{NC(OFF)}$, $I_{NO(OFF)}$	Source OFF Leakage Current	V_{NO} , $V_{NC}=3.3V$, 0.3V $V_{COM} = 0.3V/3.3V$	4.2	-40 to 85°C			50	nA
$I_{NC(ON)}$, $I_{NO(ON)}$, $I_{COM(ON)}$	Channel ON Leakage Current	V_{NO} , $V_{NC}=3.3V$, 0.3V or floating $V_{COM} = 0.3V/3.3V$	4.2	-40 to 85°C			50	nA
Digital Inputs								
V_{INH}	Input High Voltage			-40 to 85°C	1.5			V
V_{INL}	Input Low Voltage			-40 to 85°C			0.5	V
I_{IN}	Input Leakage Current	$V_{CC}=4.2V$, $V_{IN}=0V$, or 4.2V		-40 to 85°C			1	μA
Dynamic Characteristics								
t_{ON}	Turn-On Time	$V_{IN}=2.1V$ to 0V, $R_L=50 \Omega$, $C_L=35pF$, V_{NO1} or V_{NO2} or $V_{NC2}=2.1V$,		25°C		25		ns
t_{OFF}	Turn-Off Time	$V_{IN}=2.1V$ to 0V, $R_L=50 \Omega$, $C_L=35pF$, V_{NO1} or V_{NO2} or $V_{NC2}=2.1V$,		25°C		35		ns



DIO1268

Ultra Low On-Resistance Dual, SPDT Analog Switch

t_D	Break-Before-Make Time Delay	$V_{IN}=2.1V$ to $0V$, $R_L=50\ \Omega$, $C_L=35pF$, V_{NO1} or V_{NO2} or $V_{NC2}=2.1V$,		$25^\circ C$		45		ns
O_{ISO}	Off Isolation	$V_{BIAS}=2.1V$, Signal=0dBm	100kHz	$25^\circ C$		-78		dB
			1MHz			-58		
X_{TALK}	Channel-to-Channel Crosstalk	$V_{BIAS}=2.1V$, Signal=0dBm	100kHz	$25^\circ C$		-100		dB
			1MHz			-75		
BW	-3dB Bandwidth	$V_{BIAS}=2.1V$, Signal=0dBm		$25^\circ C$		75		MHz
THD	Total Harmonic Distortion	$f=20Hz$ to $20kHz$, $R_L=32\ \Omega$, $V_{SW}=1V_{PP}$		$25^\circ C$		0.02		%
Q	Charge Injection Select Input to Common I/O	$V_G=0V$, $R_S=0\ \Omega$, $C_L=1.0nF$		$25^\circ C$		4.0		pC
C_{ON}	Channel ON Capacitance			$25^\circ C$		106		pF

Electrical Characteristics

All typical value are at $V_{CC}=4.2V$, $GND=0V$, $V_{IH}=1.5V$, $V_{IL}=0.5V$, $T_A=25^\circ C$ unless otherwise specified.

Symbol	Parameter	Conditions	V_{CC}/V	Temp	Min	Typ	Max	Unit
Power Requirements								
V_{CC}	Power Supply Range			-40 to $85^\circ C$	1.6		4.2	V
I_{CC}	Quiescent Supply Current	$V_{IN}=0V$ or V_{CC}	4.2	-40 to $85^\circ C$			500	nA
I_{CCT}	Increase in I_{CC} per Input	Input at 2.6V	4.2	-40 to $85^\circ C$			5	μA
		Input at 1.6V					10	

Specifications subject to change without notice.

Test Diagrams

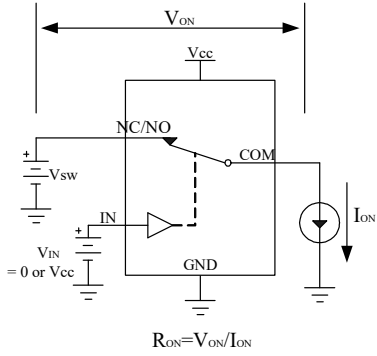

Figure 2 Switch on resistor

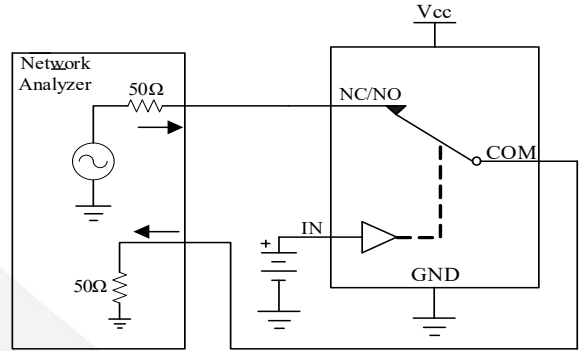

Figure 5 Bandwidth

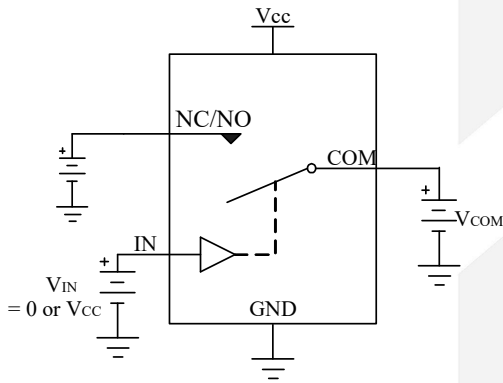

Figure 3 Switch Off Leakage

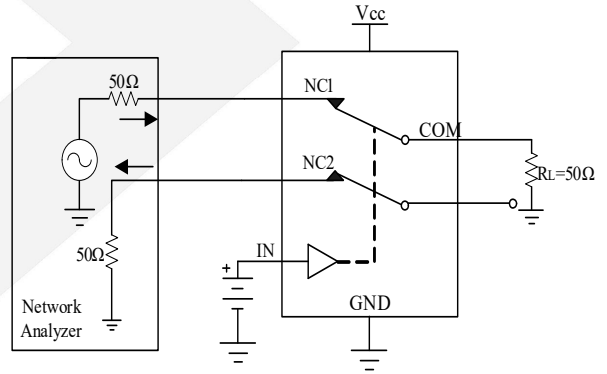

Figure 6 Channel-to-channel crosstalk

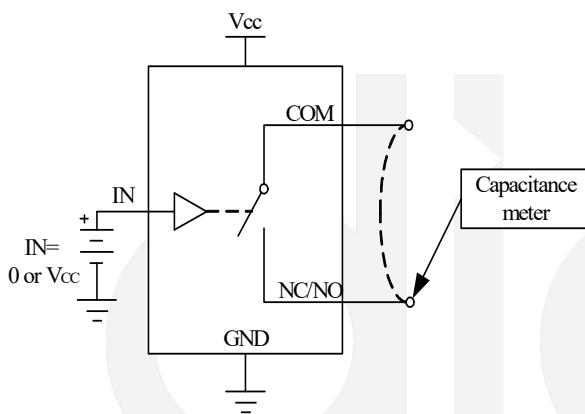

Figure 4 On/off Capacitance test

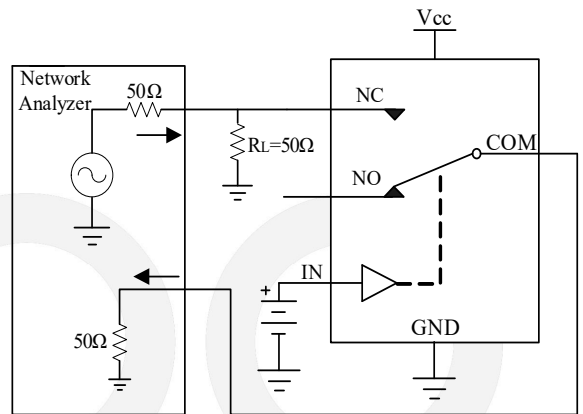

Figure 7 Off-isolation

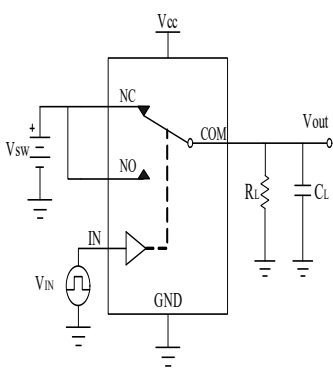

Figure 8 Break-Before-Make

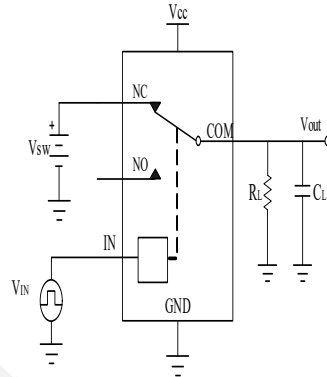
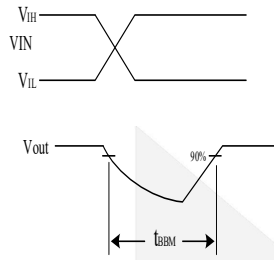
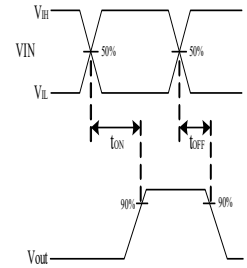

Figure 9 Turn-On/Turn-Off



dioo



DIO1268

Ultra Low On-Resistance Dual, SPDT Analog Switch

CONTACT US

Dioo is a professional design and sales corporation for high-quality and performance analog semiconductors. The company focuses on industry markets, such as, cell phone, handheld products, laptop, and medical equipment and so on. Dioo's product families include analog signal processing and amplifying, LED drivers and charger IC. Go to <http://www.dioo.com> for a complete list of Dioo product families.

For additional product information, or full datasheet, please contact with our Sales Department or Representatives.

dioo

X-ON Electronics

Largest Supplier of Electrical and Electronic Components

Click to view similar products for [Analogue Switch ICs category](#):

Click to view products by [Dioo manufacturer](#):

Other Similar products are found below :

[FSA3051TMX](#) [NLVAS4599DTT1G](#) [MAX4992EVB+T](#) [MAX4684ETB+T](#) [BCM6522IPBG](#) [BCM65300IFSBG](#) [MAX14764ETA+T](#)
[TMUX1113RSVR](#) [TMUX1112RSVR](#) [ADG1436TRUZ-EP](#) [BL4684C](#) [PE423422A](#) [PE42359SCAA](#) [PE42540F](#) [RS550YUCM12](#)
[ADGS1414DBCCZ](#) [ADG658YRUZ-REEL7](#) [RS2117YUTQK10](#) [RS2118YUTQK10](#) [RS2227XUTQK10](#) [SP2526A-1EN-L/TR](#) [FSA4157P6X](#)
[BA7603F-E2](#) [MAX4702EUE+](#) [MAX4617CUE+](#) [MAX4599EUT+T](#) [MAX4066ESD+](#) [MAX4052ACSE+](#) [MAX396CAI+](#) [MAX391CPE+](#)
[MAX4730EXT+T](#) [MAX314CPE+](#) [MAX4051AEEE+](#) [BU4066BCFV-E2](#) [MAX313CPE+](#) [BU4S66G2-TR](#) [TS3A4751PWR](#)
[NCN1154MUTAG](#) [DG444DY-E3](#) [NLAS4157DFT2G](#) [NLAS4599DFT2G](#) [NLAS7242MUTBG](#) [NLASB3157DFT2G](#) [NLAST4599DFT2G](#)
[NLAST4599DTT1G](#) [DG403DY-T1-E3](#) [MAX4714EXTT](#) [MAX392CPE](#) [BGSX22G2A10E6327XTSA1](#) [ADG1611BRUZ-REEL7](#)