

# DIO1567

## Low Power, Dual SIM Card Analog Switch

### Features

- Switch Type: SPDT(4X)
- Voltage Operation: 1.6V to 4.5V
- Low On Resistance: 0.65Ω at SIM path;  
2.7Ω at other path
- Bandwidth >200MHz
- 10pF C<sub>ON</sub> at DAT/CLK/RST path
- Low power consumption
- Packaged: 16-Lead DQFN and  
16-Lead TQFN
- 6kV HBM ESD

### Descriptions

The DIO1567 is a quad Single-Pole, Double-Throw (SPDT) analog switch targeted at dual SIM card multiplexing. DIO1567 operates from a single 1.6V to 4.5V supply and features an ultra-low on resistance of 0.65Ω at SIM path to ensure minimal voltage drop in other path. This device is fabricated with sub-micron CMOS technology to achieve fast switching speeds and is designed for break-before-make operation.

DIO1567 features very low quiescent current even when the control voltage is lower than the V<sub>CC</sub> supply. This allows mobile handset applications direct interface with the baseband processor general-purpose I/Os.

DIO1567 provides two packages with Green DQFN-16 and TQFN-16.

### Applications

- Cell-Phone/PDA
- Set-Top Box
- Digital Camera
- Notebook
- TV/ LCD Monitor

### Block Diagram

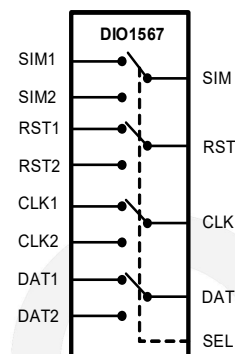

### Ordering Information

Order Part Number	Top Marking		T <sub>A</sub>	Package	
DIO1567LN16	D15	Green	-40 to 85°C	DQFN-16	Tape & Reel, 3000
DIO1567CL16	D1567	Green	-40 to 85°C	TQFN-16	Tape & Reel, 5000

## Pin Assignment

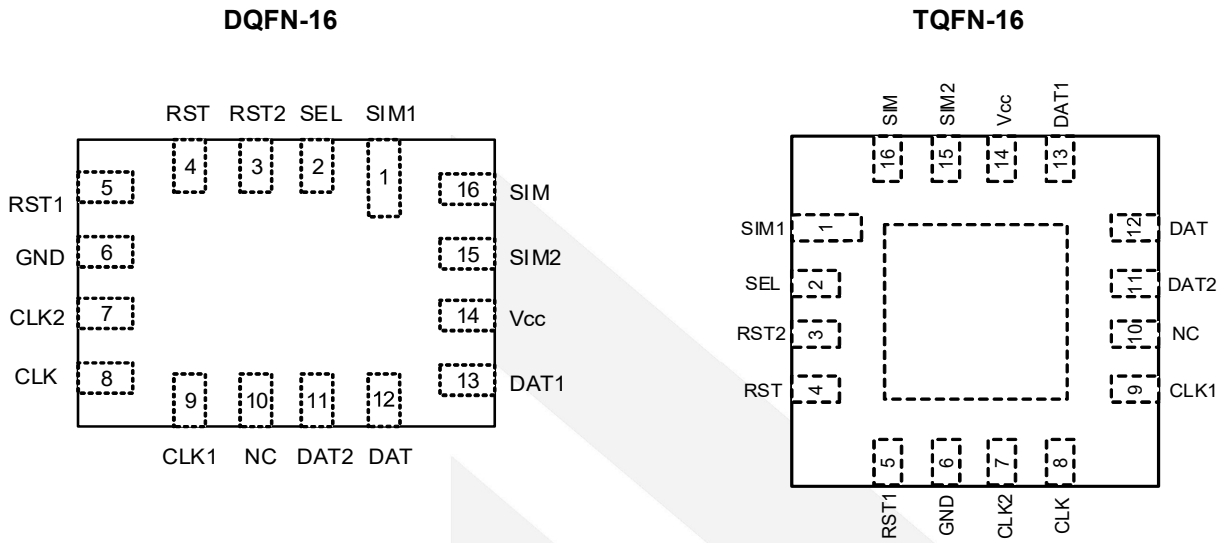

Figure 1 Top View

## Pin Descriptions

Pin Name	Description
DATn, RSTn, CLKn	Data Input
SIMn	SIM Input
SIM, DAT, CLK, RST	Common Port
SEL	Select
V <sub>cc</sub> / GND	Power

## Truth Table

SEL	Function
L	SIM=SIM1, DAT=DAT1, RST=RST1, CLK=CLK1
H	SIM=SIM2, DAT=DAT2, RST=RST2, CLK=CLK2



# DIO1567

## Absolute Maximum Ratings

Stresses beyond those listed under "Absolute Maximum Rating" may cause permanent damage to the device. These are stress ratings only and functional operation of the device at these or any other condition beyond those indicated in the operational sections of the specifications is not implied. Exposure to absolute maximum rating conditions for extended periods may affect device reliability

Symbol	Parameter	Min.	Max.	Unit
V <sub>CC</sub>	Supply Voltage	-0.5	5.25	V
V <sub>S</sub>	Switch Voltage	-0.5	V <sub>CC</sub> +0.3	V
V <sub>IN</sub>	DC input I/O Voltage	-0.5	V <sub>CC</sub>	V
I <sub>IK</sub>	DC input Diode current	-50		mA
I <sub>OUT</sub>	DC output current (DAT, CLK, RST, SIM)		400	mA
I <sub>Peak</sub>	Peak current(pulsed at 1ms,10% duty cycle)		500	mA
P <sub>D</sub>	Continuous Power Dissipation(T <sub>A</sub> =85°C) (15.6mW/°C above 85°C)		1.25	W
T <sub>STG</sub>	Storage Temperature Range	-65	150	°C
T <sub>J</sub>	Junction Temperature		150	°C
	Lead Temperature(soldering 10s)		260	°C
ESD	HBM, JEDEC: JESD22-A114		6	kV

## Recommend Operating Conditions

The Recommended Operating Conditions table defines the conditions for actual device operation. Recommended Operating conditions are specified to ensure optimal performance to the datasheet specifications. DIOO does not Recommend exceeding them or designing to Absolute Maximum Ratings.

Symbol	Parameter	Min.	Max.	Unit
V <sub>CC</sub>	Supply voltage	1.6	4.5	V
V <sub>IN</sub>	Control input voltage (1S,2S)	0	V <sub>CC</sub>	V
V <sub>S</sub>	Switch I/O voltage	0	V <sub>CC</sub>	V
I <sub>OUT</sub>	DC output current (DAT, CLK, RST)		50	mA
I <sub>SIM</sub>	DC output current (SIM)		150	mA
T <sub>A</sub>	Operating Temperature	-40	85	°C



# DIO1567

Low Power, Dual SIM Card Analog Switch

## DC Electrical Characteristics

All typical value is at 25°C unless otherwise specified.

Symbol	Parameter	Conditions	V <sub>CC</sub> (V)	Temp.	Min.	Typ.	Max.	Unit
V <sub>IH</sub>	Input voltage high		4.5	-40 to 85°C	1.7			V
			2.7		1.3			
V <sub>IL</sub>	Input voltage low		4.5	-40 to 85°C			0.6	V
			2.7				0.4	
I <sub>IN</sub>	Control input leakage	V <sub>SW</sub> =0 to V <sub>CC</sub>	4.5	25°C	-1		1	nA
I <sub>NC(OFF)</sub> I <sub>NO(OFF)</sub>	Off Leakage Current	RSTn, DATn, CLKn, SIMn=0.3 or 3.6V	4.5	25°C	-80		80	nA
I <sub>NC(ON)</sub> I <sub>NO(ON)</sub>	ON Leakage Current	RSTn, DATn, CLKn, SIMn=0.3 or 3.6V	4.5	25°C	-80		80	nA
I <sub>CC</sub>	Quiescent supply current	V <sub>IN</sub> =0V to V <sub>CC</sub> , I <sub>OUT</sub> =0V	4.5	25°C		5	500	nA
R <sub>OND</sub>	RST, DAT, CLK, Resistance	I <sub>OUT</sub> =-20mA, V <sub>SW</sub> =2.3V	2.7	-40 to 85°C		2.7		Ω
R <sub>ONS</sub>	SIM Resistance	I <sub>OUT</sub> =-100mA, V <sub>SW</sub> =2.3V	2.7	-40 to 85°C		0.65		Ω
ΔR <sub>ON</sub>	Delta On Resistance	V <sub>SW</sub> =0V, I <sub>ON</sub> =-20mA	2.7	-40 to 85°C		0.2		Ω
R <sub>FLAT(ON)</sub>	On Resistance Flatness	I <sub>OUT</sub> =100mA, nB <sub>0</sub> , nB <sub>1</sub> =0 to V <sub>CC</sub>	2.7	-40 to 85°C			0.8	Ω
I <sub>CCCT</sub>	Increase in I <sub>CC</sub> Current Per Control Voltage and V <sub>CC</sub>	V <sub>IN</sub> =1.8V	4.5	25°C		7		μA
		V <sub>IN</sub> =2.6V	4.5	25°C		3		μA

## Capacitance

Symbol	Parameter	Conditions	Temp.	Min.	Typ.	Max.	Unit
C <sub>IN</sub>	Control Pin Input Capacitance		-40 to 85°C		2		pF
C <sub>OND</sub>	DAT, CLK, RST On Capacitance	f=1MHz	-40 to 85°C		10		pF
C <sub>ONS</sub>	SIM On Capacitance	f=1MHz	-40 to 85°C		100		pF
C <sub>OFFD</sub>	DAT, CLK, RST Off Capacitance	f=1MHz	-40 to 85°C		5		pF
C <sub>OFFS</sub>	SIM Off Capacitance	f=1MHz	-40 to 85°C		30		pF



# DIO1567

Low Power, Dual SIM Card Analog Switch

## AC Electrical Characteristics

All typical value are for  $V_{CC} = 3.3V$  at  $25^{\circ}C$  unless otherwise specified.

Symbol	Parameter	Conditions	$V_{CC}(V)$	Temp.	Min.	Typ.	Max.	Unit
$t_{OND}$	Turn-On time (DAT, CLK, RST)	$R_L=50\Omega$ , $C_L=35pF$ , $V_{SW}=1.5V$	2.7 to 3.6	-40 to $85^{\circ}C$		57		ns
$t_{OFFD}$	Turn-Off time (DAT, CLK, RST)	$R_L=50\Omega$ , $C_L=35pF$ , $V_{SW}=1.5V$	2.7 to 3.6	-40 to $85^{\circ}C$		55		ns
$t_{ONS}$	Turn-On time (SIM)	$R_L=50\Omega$ , $C_L=35pF$ , $V_{SW}=1.5V$	2.7 to 3.6	-40 to $85^{\circ}C$		57		ns
$t_{OFFS}$	Turn-Off time (SIM)	$R_L=50\Omega$ , $C_L=35pF$ , $V_{SW}=1.5V$	2.7 to 3.6	-40 to $85^{\circ}C$		55		ns
$t_{BBMD}$	Break-Before-Make	$R_L=50\Omega$ , $C_L=35pF$ , $V_{SW}=1.5V$	2.7 to 3.6	$25^{\circ}C$		38		ns
$t_{PD}$	Propagation delay (DAT, CLK, RST)	$R_L=50\Omega$ , $C_L=35pF$	3.3	$25^{\circ}C$			0.5	ns
OIRR	Off Isolation (DAT, CLK, RST)	$R_L=50\Omega$ , $f=10MHz$ ,	2.7 to 3.6	$25^{\circ}C$		-52		dB
Xtalk	Non-Adjacent Channel Crosstalk (DAT, CLK, RST)	$R_L=50\Omega$ , $f=10MHz$	2.7 to 3.6	$25^{\circ}C$		-75		dB
BW	-3dB bandwidth (DAT, CLK, RST)	$R_L=50\Omega$ , $C_L=5pF$ ,	2.7 to 3.6	$25^{\circ}C$		200		MHz
	-3dB bandwidth (SIM)	$R_L=50\Omega$ , $C_L=5pF$ ,	2.7 to 3.6	$25^{\circ}C$		37		MHz

Specifications subject to change without notice.

Test Diagrams

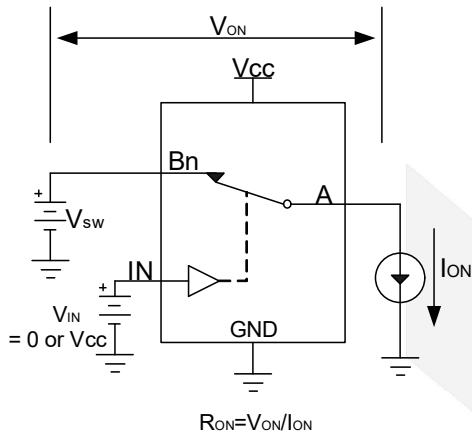

Figure 2 Switch on resistor

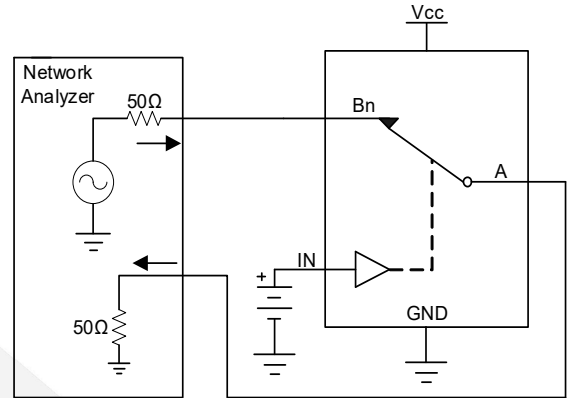

Figure 5 Bandwidth

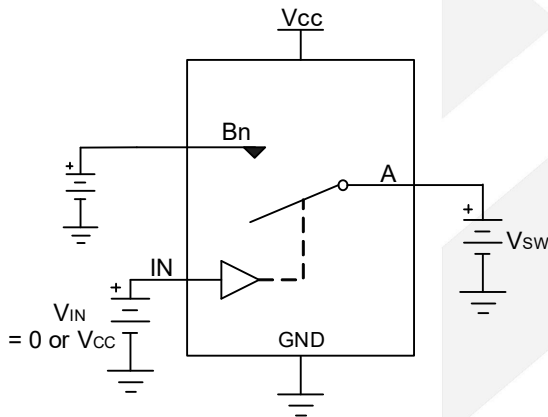

Figure 3 Switch Off Leakage

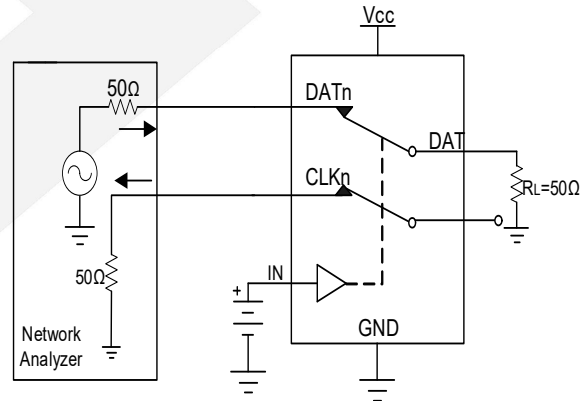

Figure 6 Channel-to-channel crosstalk

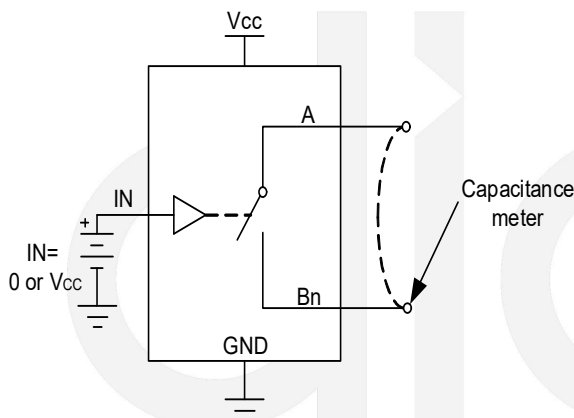

Figure 4 On/off Capacitance test

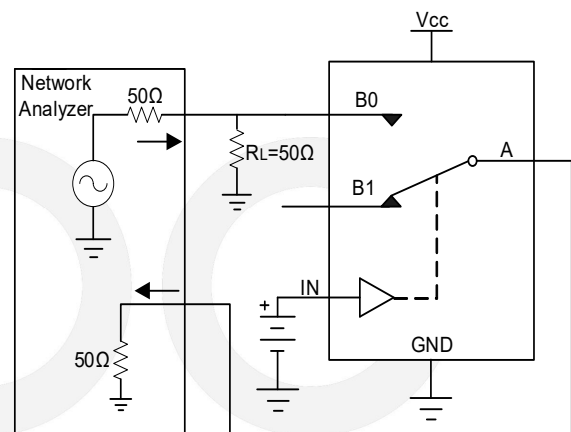

Figure 7 Off-isolation

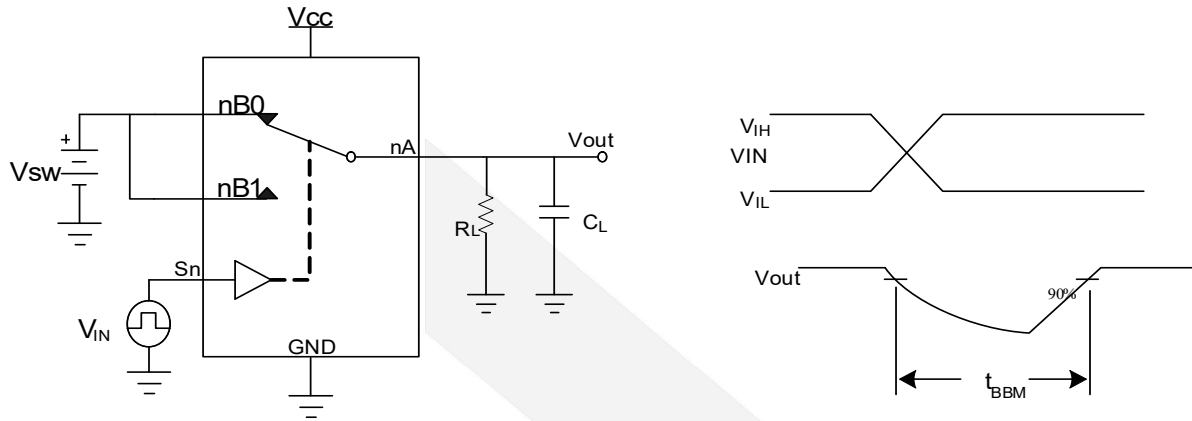

Figure 8 Break-Before-Make

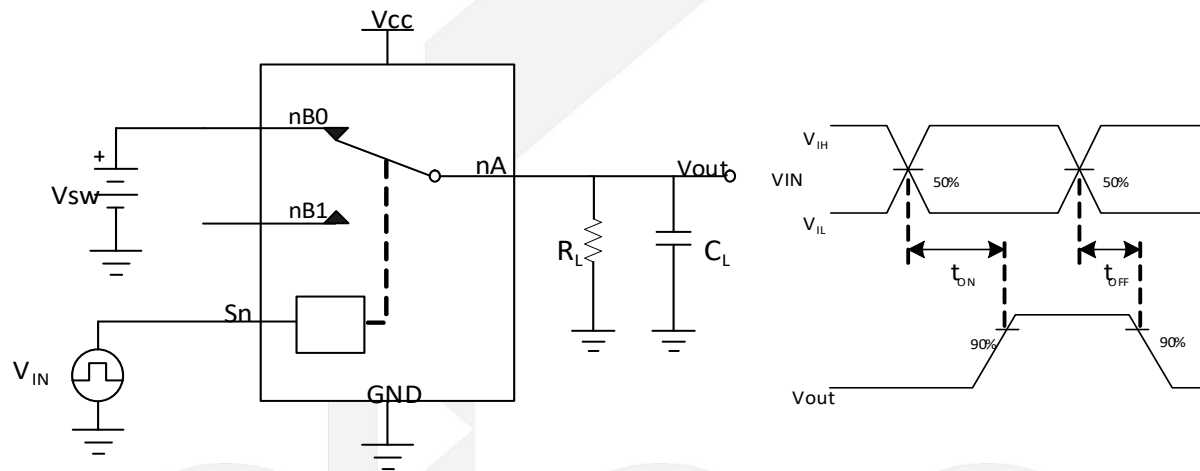

Figure 9 Turn-On/Turn-Off

## CONTACT US

Dioo is a professional design and sales corporation for high-quality and performance analog semiconductors. The company focuses on industry markets, such as, cell phone, handheld products, laptop, and medical equipment and so on. Dioo's product families include analog signal processing and amplifying, LED drivers and charger IC. Go to <http://www.dioo.com> for a complete list of Dioo product families.

For additional product information, or full datasheet, please contact with our Sales Department or Representatives.





## X-ON Electronics

Largest Supplier of Electrical and Electronic Components

*Click to view similar products for [Analogue Switch ICs category](#):*

*Click to view products by [Dioo manufacturer](#):*

Other Similar products are found below :

[FSA3051TMX](#) [NLAS5223BLMNR2G](#) [NLX2G66DMUTCG](#) [TC74HC4066AFTEL](#) [425541DB](#) [DG403DY](#) [099044FB](#) [MAX4762ETB+](#)  
[NLAS3799BMNR2G](#) [NLAS5123MNR2G](#) [ISL84684IR](#) [PI5A4157CEX](#) [PI5A4599BCEX](#) [NLAS4717EPFCT1G](#) [PI5A3167CCEX](#)  
[SLAS3158MNR2G](#) [PI5A392AQE](#) [ADG714BCPZ-REEL7](#) [DG333ALDW-T1-E3](#) [ISL43113IB](#) [ISL43140IB](#) [ISL43140IBZ-T](#) [ISL43143IR](#)  
[ISL43L120IR](#) [ISL43L121IR](#) [ISL43L122IR](#) [ISL43L220IR](#) [ISL43L410IR](#) [ISL43L420IR](#) [ISL43L710IR](#) [ISL43L711IR](#) [ISL43L712IR](#)  
[ISL84053IA](#) [ISL84514IB](#) [ISL84516IB](#) [ISL84684IUZ-T](#) [LNLASB3157DFT2G](#) [NLAS324US](#) [NLASTV4599DFT2G](#) [TPW4053-SR](#)  
[WAS4642Q-24/TR](#) [WAS4766C-9/TR](#) [WAS7227Q-10/TR](#) [WAS4646C-36/TR](#) [WAS4735Q-16/TR](#) [BL1532TQFN](#) [RS2233YS16](#)  
[TMUX1248DCKR](#) [TMUX7236RUMR](#) [ADG836YRMZ-REEL](#)