

DIO2022x

190μA, 3MHz RRIO CMOS Amplifier

Features

- Rail-to-Rail Input and Output
- $\pm 1\text{mV}$ Typical offset (V_{OS})
- V_{OSMAX} Specificity: $\pm 5\text{mV}$
- Low Distortion
- Gain Bandwidth Product: 3MHz
- Wide supply range: 2.5V to 5.5V
- 190μA/Amplifier typical supply current
- Slew rate: 1.7V/μs
- Small size packaging best for portable applications.
- DIO20221: Available in SC70-5, SOT23-5
DIO20222: Available in MSOP-8, SOIC-8
DIO20224: Available in SOIC-14 and TSSOP-14

Applications

- Portable Equipment
- Active Filters
- Data Acquisition
- Portable Equipment
- Test Equipment
- Broadband Communication
- Process Control
- Audio and Video Processing

Ordering Information

Order Part Number	Top Marking		T_A	Package	
DIO20221SC5	YWXC	RoHS or Green	-40 to 125°C	SC70-5	Tape & Reel, 3000
DIO20221ST5	YWXC	RoHS or Green	-40 to 125°C	SOT23-5	Tape & Reel, 3000
DIO20222MP8	DIO2022	RoHS or Green	-40 to 125°C	MSOP-8	Tape & Reel, 3000
DIO20222SO8	DIO2022	RoHS or Green	-40 to 125°C	SOIC-8	Tape & Reel, 2500
DIO20224CS14	DIO2024	RoHS or Green	-40 to 125°C	SOIC-14	Tape & Reel, 2500
DIO20224CT14	DIO2024	RoHS or Green	-40 to 125°C	TSSOP-14	Tape & Reel, 2500

Descriptions

The DIO2022x is a rail-to-rail I/O operational amplifier which allows low load impedances to be driven. With a 3MHz unity-gain frequency and low noise, low distortion and high output current capability, the DIO2022x provides excellent choice for high quality systems. The input common-mode voltage range includes ground, and the maximum input offset voltage is $\pm 1\text{mV}$ (guaranteed). They are also capable of comfortably driving large capacitive loads.

DIO2022x is offered in RoHS or Green package and ESD (HBM) 8kV. It is specified over the extended -40 to 125°C

Typical Application

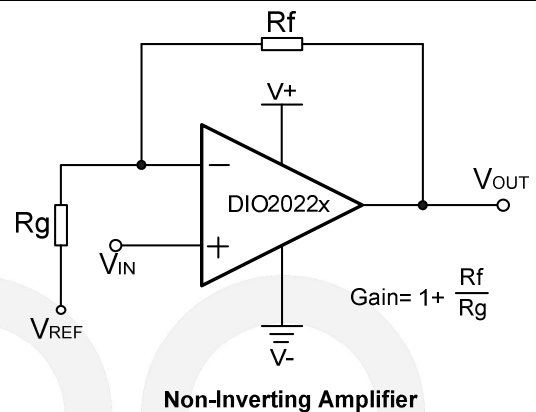

Pin Assignments

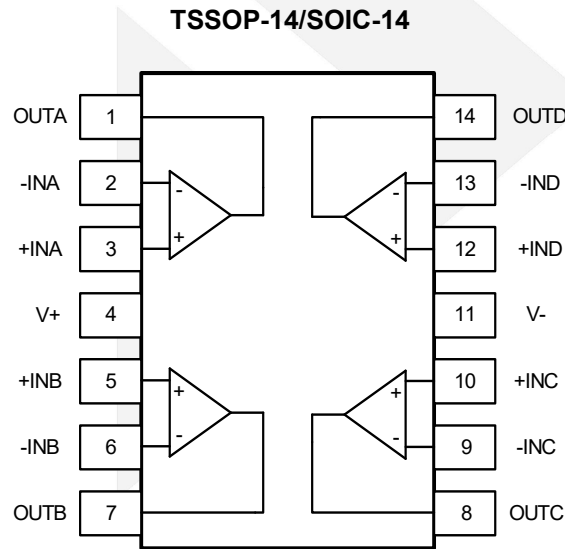
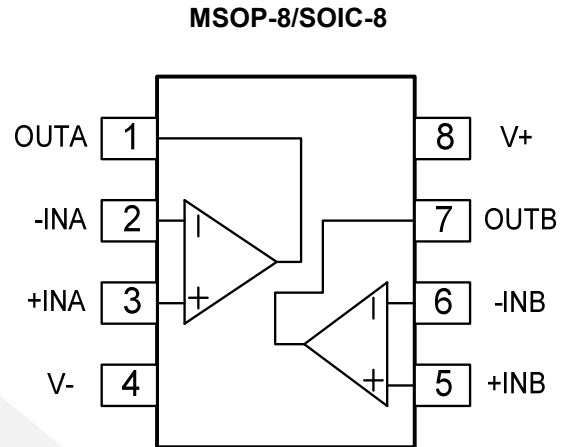
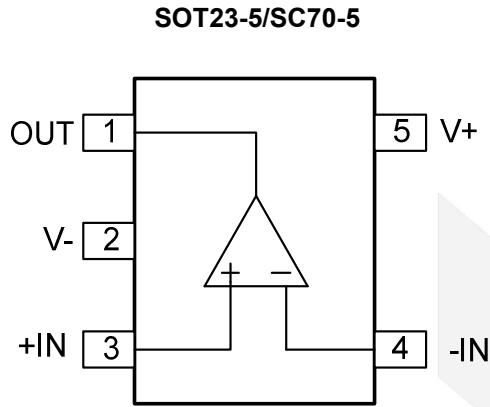

Figure 1 Pin Assignment (Top View)

Pin Description

Pin name	Description
V+	Positive supply
V-	Negative supply
+INX	Positive Input
-INX	Negative Input
OUTX	Output

Absolute Maximum Ratings

Stresses beyond those listed under “Absolute Maximum Rating” may cause permanent damage to the device. These are stress ratings only and functional operation of the device at these or any other condition beyond those indicated in the operational sections of the specifications is not implied. Exposure to absolute maximum rating conditions for extended periods may affect device reliability.

Parameter		Rating	Unit
Supply Voltage		7.5	V
Input Voltage		(V ₋)-0.5 to (V ₊)+0.5	V
Storage Temperature Range		-65 to 150	°C
Junction Temperature		150	°C
Lead Temperature Range		260	°C
ESD	HBM, JEDEC: JESD22-A114	8	kV
	CDM, JEDEC: JESD22-C101	2	

Recommended Operating Conditions

The Recommended Operating Conditions table defines the conditions for actual device operation to ensure optimal performance to the datasheet specifications. DIOO does not recommend exceeding them or designing to Absolute Maximum Ratings.

Parameter		Rating	Unit
Supply Voltage		2.5 to 5.5	V
Input Voltage		0 to 5	V
Operating Temperature Range		-40 to 125	°C



Electrical Characteristics

Typical value: $V_+ = 5V$, $R_L = 100k\Omega$ to $V_+/2$, $T_A = 25^\circ C$, unless otherwise specified.

Symbol	Parameter	Conditions	Min.	Typ.	Max.	Unit
INPUT CHARACTERISTICS						
V_{OS}	Input Offset Voltage	$-40^\circ C \leq T_A \leq 125^\circ C$, $V_+ = 2.5V$ to $5.5V$		± 1.0	± 5.0	mV
I_B	Input Bias Current	$-40^\circ C \leq T_A \leq 125^\circ C$, $V_+ = 2.5V$ to $5.5V$		1.0	10	pA
I_{OS}	Input Offset Current	$-40^\circ C \leq T_A \leq 125^\circ C$, $V_+ = 2.5V$ to $5.5V$		1.0	10	pA
V_{CM}	Common Mode Voltage Range	$V_+ = 5.5V$	-0.1		(V_+) +0.1	V
CMRR	Common Mode Rejection Ratio	$-40^\circ C \leq T_A \leq 125^\circ C$, $V_{CM} = -0.1$ to $5.6V$, $V_+ = 5.5V$	80	120		dB
A_{OL}	Open Loop Voltage Gain	$R_L = 600\Omega$, $V_o = 0.1$ to 4.9	90	120		dB
$\Delta V_{OS}/\Delta T$	Input Offset Voltage Drift	$-40^\circ C \leq T_A \leq 125^\circ C$		2.5		$\mu V/^\circ C$
OUTPUT CHARACTERISTICS						
	Output Voltage Swing from Rail	$R_L = 600\Omega$ $-40^\circ C \leq T_A \leq 125^\circ C$			0.1	V
		$R_L = 10k\Omega$ $-40^\circ C \leq T_A \leq 125^\circ C$			0.015	
I_{OUT}	Output Current	$V_+ = 5V$	80	85		mA
		$V_+ = 2.5V$	5	15		
R_o	Closed Loop Output Impedance	$f = 100kHz$, $G = +1$, $V_+ = 5V$		2.0		Ω
		$f = 100kHz$, $G = +1$, $V_+ = 2.5V$		4.2		
POWER SUPPLY						
PSRR	Power Supply Rejection Ration		70	80		dB
I_S	Supply Current per Channel/Amp	$V_+ = 5V$, $-40^\circ C \leq T_A \leq 125^\circ C$		190	300	μA
		$V_+ = 2.5V$, $-40^\circ C \leq T_A \leq 125^\circ C$		160	280	
DYNAMIC PERFORMANCE						
GBP	Gain Bandwidth Product	$R_L = 10k\Omega$		3.0		MHz
SR	Slew Rate	$R_L = 600\Omega$, $G = 1$, 2V Output Step		1.7		V/ μs
t_s	Setting Time	$R_L = 600\Omega$, $G = 1$, 2V Output Step			1.0	μs
X_{talk}	Channel Separation	$f = 1kHz$, $R_L = 10k\Omega$		110		dB
	Overload Recovery Time	$V_{IN} \times Gain = V_+$		1.0		μs
NOISE PERFORMANCE						
THD	Total Harmonic Distortion	$f = 10kHz$, 1V Output Step, $R_L = 600\Omega$ and $100pF$		0.015		%
e_n	Voltage Noise Density	$f = 1kHz$, $V_+ = 5V$		27		nV/ \sqrt{Hz}
		$f = 10kHz$, $V_+ = 5V$		18		

Specifications subject to change without notice.

Typical Performance Characteristics

Supply Current vs. Supply Voltage Per Channel

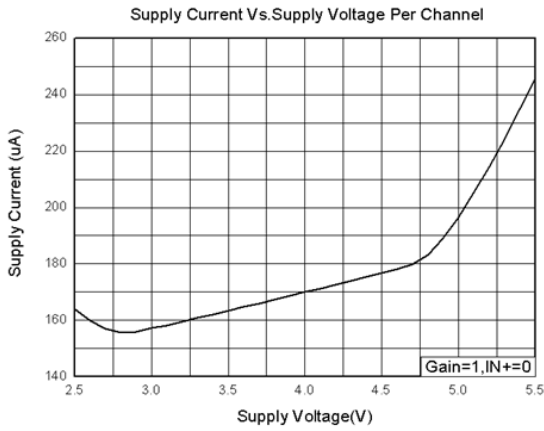

Supply Current vs. Temperature

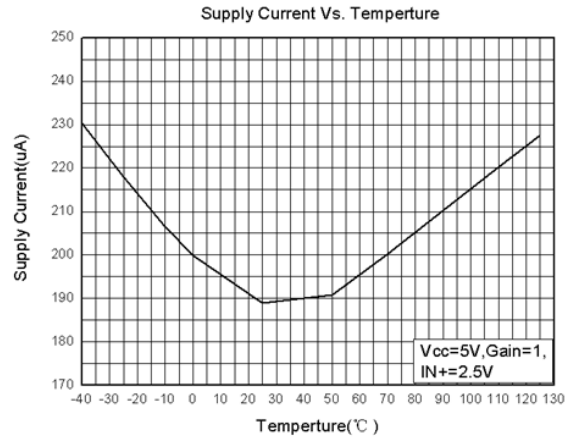

Gain vs. Frequency

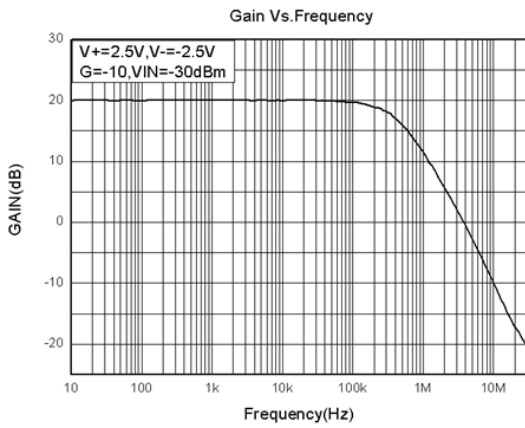

Input Offset Voltage vs. Temperature

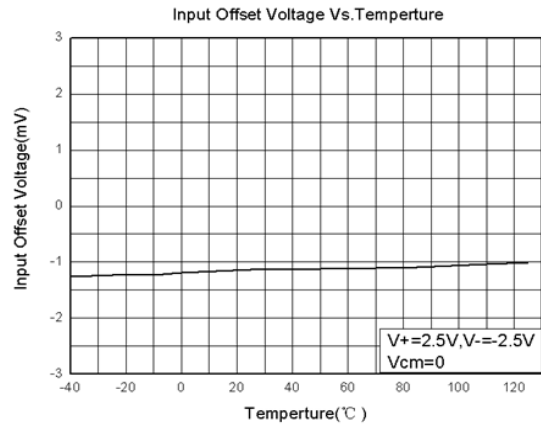

Input Offset Voltage vs. Supply Voltage

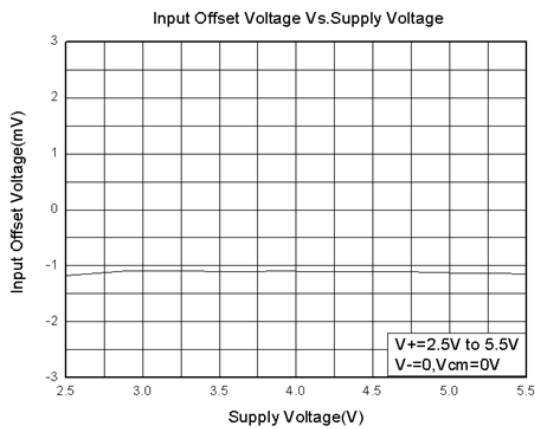

Input Offset Voltage vs. Common Voltage

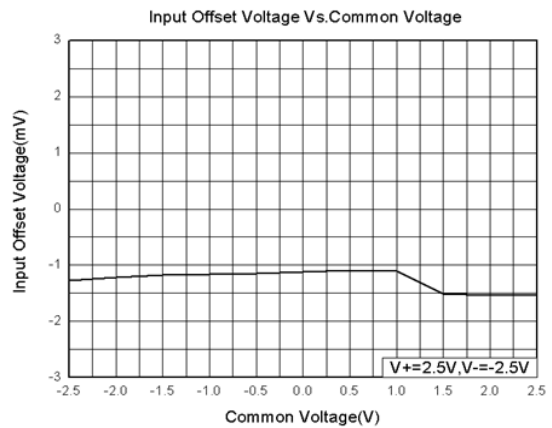

Small-signal Response ($V_+=5V$, $C_L=200pF$)

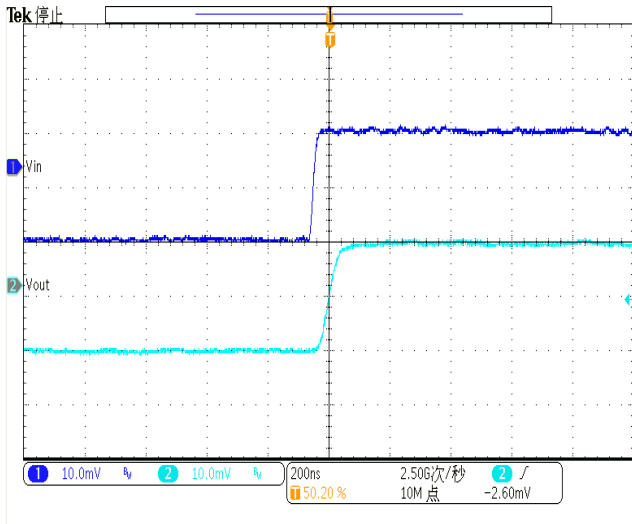

Small-signal Response ($V_+=5V$, $C_L=200pF$)

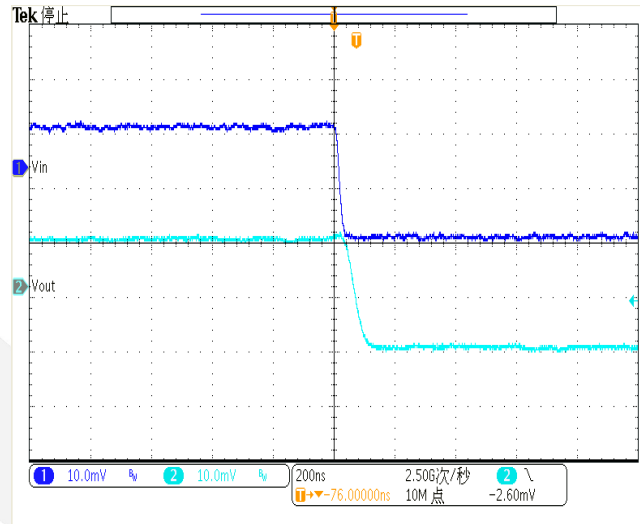

Large-Signal Response ($V_+=5V$, $R_L=1M\Omega$)

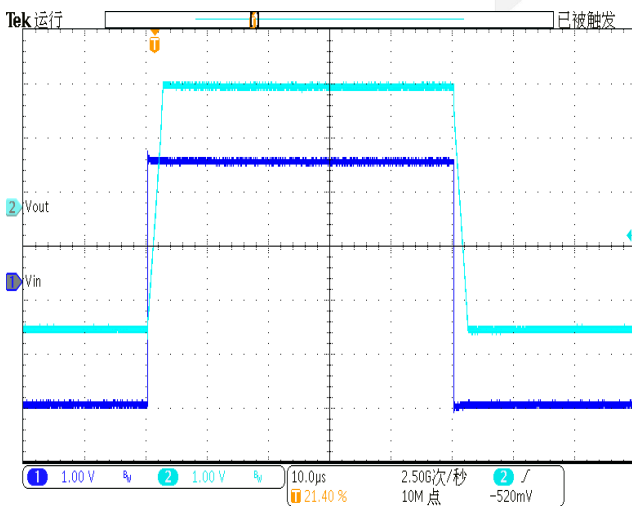

CONTACT US

Dioo is a professional design and sales corporation for high-quality and performance analog semiconductors. The company focuses on industry markets, such as, cell phone, handheld products, laptop, and medical equipment and so on. Dioo's product families include analog signal processing and amplifying, LED drivers and charger IC. Go to <http://www.dioo.com> for a complete list of Dioo product families.

For additional product information, or full datasheet, please contact with our Sales Department or Representatives.



X-ON Electronics

Largest Supplier of Electrical and Electronic Components

Click to view similar products for [Operational Amplifiers - Op Amps](#) category:

Click to view products by [Dioo](#) manufacturer:

Other Similar products are found below :

[NCV33072ADR2G](#) [LM258AYDT](#) [LM358SNG](#) [430227FB](#) [UPC824G2-A](#) [LT1678IS8](#) [042225DB](#) [058184EB](#) [UPC822G2-A](#) [UPC259G2-A](#)
[UPC258G2-A](#) [NCV33202DMR2G](#) [NTE925](#) [AZV358MTR-G1](#) [AP4310AUMTR-AG1](#) [HA1630D02MMEL-E](#) [HA1630S01LPEL-E](#)
[SCY33178DR2G](#) [NJU77806F3-TE1](#) [NCV5652MUTWG](#) [NCV20034DR2G](#) [LM324EDR2G](#) [LM2902EDR2G](#) [NTE7155](#) [NTE778S](#) [NTE871](#)
[NTE924](#) [NTE937](#) [MCP6V17T-E/MNY](#) [MCP6V19-E/ST](#) [MXD8011HF](#) [MCP6V16UT-E/OT](#) [MCP6V17T-E/MS](#) [MCP6V19T-E/ST](#)
[SCY6358ADR2G](#) [ADA4523-1BCPZ](#) [LTC2065HUD#PBF](#) [ADA4523-1BCPZ-RL7](#) [2SD965T-R](#) [RS6332PXK](#) [BDM8551](#) [BDM321](#) [MD1324](#)
[COS8052SR](#) [COS8552SR](#) [COS8554SR](#) [COS2177SR](#) [COS2353SR](#) [COS724TR](#) [LM2902M/TR](#)