

## DIO2031/2032/2033/2034/2036

### 500 $\mu$ A, 6MHz, Rail-to-Rail I/O CMOS Operational Amplifiers

#### Features

- Supply Voltage Range: 2.5V to 5.5V
- Low Supply Current: 500 $\mu$ A Typically
- Rail-to-Rail Input and Output
- 6MHz High Gain-Bandwidth Product
- High Slew Rate: 3.6V/ $\mu$ s
- Settling Time to 0.1% with 2V Step: 2.1 $\mu$ s
- Overload Recovery Time: 0.9 $\mu$ s
- Packages:  
 DIO2031 Available in: SOT23-5/SOIC-8  
 DIO2032 Available in:  
 SOIC-8/MSOP-8/TSSOP-8  
 DIO2033 Available in: SOT23-6/SOIC-8  
 DIO2034 Available in: TSSOP-14/SOIC-14  
 DIO2036 Available in: QFN4\*4-20

#### Applications

- Audio Output
- Sensor Interface
- Active Filters
- A/D Converters
- Cellular and Cordless Phones
- Laptops and PDAs
- Photodiode Amplification
- Battery-Powered Instrumentation

#### Ordering Information

Order Part Number	Top Marking		T <sub>A</sub>	Package	
DIO2031ST5	YWXH	RoHS/Green	-40 to +125°C	SOT23-5	Tape & Reel, 3000
DIO2031SO8	DIO2031	RoHS/Green	-40 to +125°C	SOIC-8	Tape & Reel, 2500
DIO2032SO8	DIO2032	RoHS/Green	-40 to +125°C	SOIC-8	Tape & Reel, 2500
DIO2032MP8		RoHS/Green	-40 to +125°C	MSOP-8	Tape & Reel, 3000
DIO2032TP8		RoHS/Green	-40 to +125°C	TSSOP-8	Tape & Reel, 3000
DIO2033SO8	DIO2033	RoHS/Green	-40 to +125°C	SOIC-8	Tape & Reel, 2500
DIO2033ST6	YWXM	RoHS/Green	-40 to +125°C	SOT23-6	Tape & Reel, 3000
DIO2034SO14	DIO2034	RoHS/Green	-40 to +125°C	SOP-14	Tape & Reel, 2500
DIO2034TP14		RoHS/Green	-40 to +125°C	TSSOP-14	Tape & Reel, 2500
DIO2036QN20	DIO2036	RoHS/Green	-40 to +125°C	QFN4*4-20	Tape & Reel, 5000

#### Descriptions

The DIO2031 (single), DIO2032 (dual), DIO2033 (single with shutdown), DIO2034 (quad) and DIO2036 (Triple) are amplifiers with very low noise, low voltage, and low power operational. The DIO2031/2/3/4/6 has a high gain-bandwidth product of 6MHz, a slew rate of 3.6V/ $\mu$ s, and a quiescent current of 500 $\mu$ A/amplifier at 5V typically.

The DIO2031/2/3/4/6 is designed to provide optimal performance in low voltage and low noise systems. All these chips provide rail-to-rail output swing into heavy loads. The input common-mode voltage range includes ground, and the maximum input offset voltage is 3.5mV for DIO2031/2/3/4/6.

The DIO2033 has a power-down disable feature that reduces the supply current to 90nA individually.

They are specified over the extended industrial temperature range (-40 °C to +125 °C). The operating range is from 2.5V to 5.5V.

Pin Assignments

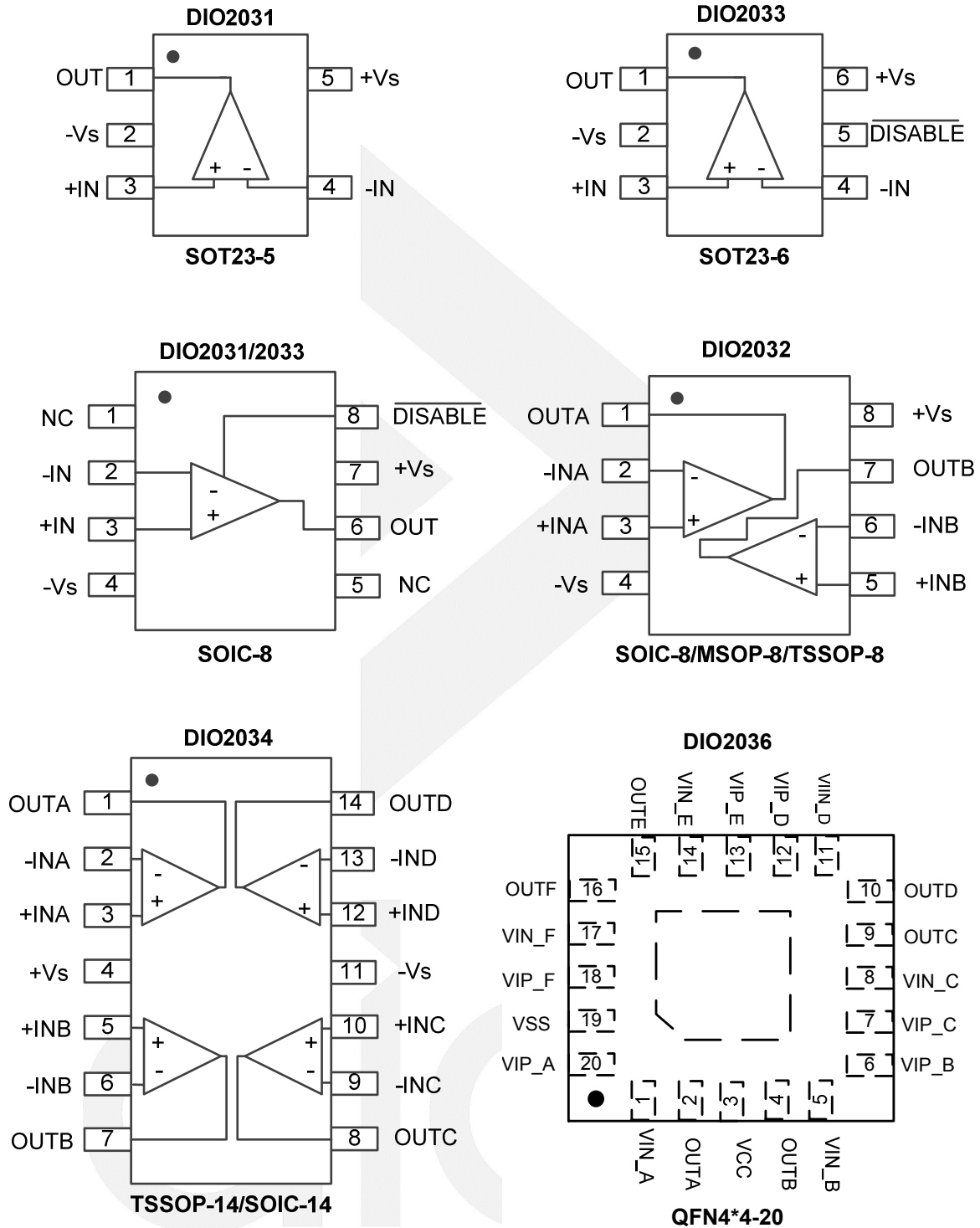



Figure 1 Pin assignment (Top View)

## Pin Description

Pin name	Description
+Vs	Positive supply
-Vs	Negative supply
+IN (+INA/+INB/+INC/+IND)	Positive Input (channel A/B/C/D)
-IN (-INA/-INB/-INC/-IND)	Negative Input (channel A/B/C/D)
OUT (OUTA/OUTB/OUTC/OUTD)	Output (channel A/B/C/D)
 DISABLE	High worked, Low not work.
NC	Not Connect

## Absolute Maximum Ratings

Stresses beyond those listed under "Absolute Maximum Rating" may cause permanent damage to the device. These are stress ratings only and functional operation of the device at these or any other condition beyond those indicated in the operational sections of the specifications is not implied. Exposure to absolute maximum rating conditions for extended periods may affect device reliability.

Parameter	Rating	Unit
Supply Voltage	7.5	V
Input Voltage	(V-)-0.5 to (V+)+0.5	V
Storage Temperature Range	-65 to 150	°C
Junction Temperature	150	°C
Lead Temperature Range	260	°C
ESD	HBM, JEDEC: JESD22-A114	kV
	CDM, JEDEC: JESD22-C101	

## Recommended Operating Conditions

The Recommended Operating Conditions table defines the conditions for actual device operation to ensure optimal performance to the datasheet specifications. DIOO does not recommend exceeding them or designing to Absolute Maximum Ratings.

Parameter	Rating	Unit
Supply Voltage	2.5 to 5.5	V
Input Voltage	0 to 5	V
Operating Temperature Range	-40 to 125	°C

## Electrical Characteristics

Typical value:  $V_+ = 5V$ ,  $R_L = 100k\Omega$  to  $V_+/2$ ,  $T_A = 25^\circ C$ , unless otherwise specified.

Symbol	Parameter	Conditions	Min.	Typ.	Max.	Unit
<b>INPUT CHARACTERISTICS</b>						
$V_{OS}$	Input Offset Voltage	$T_A = 25^\circ C$	-3.5	0.7	3.5	mV
$I_B$	Input Bias Current	$-40^\circ C \leq T_A \leq 125^\circ C$ , $V_+ = 2.5V$ to $5.5V$		1	10	pA
$I_{OS}$	Input Offset Current	$-40^\circ C \leq T_A \leq 125^\circ C$ , $V_+ = 2.5V$ to $5.5V$		1	10	pA
$V_{CM}$	Common Mode Voltage Range	$V_+ = 5.5V$	-0.1		5.6	V
$CMRR$	Common Mode Rejection Ratio	$-40^\circ C \leq T_A \leq 125^\circ C$ , $V_S = 5.5V$ , $V_{CM} = -0.1V$ to $4V$	75	90		dB
		$-40^\circ C \leq T_A \leq 125^\circ C$ , $V_S = 5.5V$ , $V_{CM} = -0.1V$ to $5.6V$	66	90		dB
$A_{OL}$	Open Loop Voltage Gain	$R_L = 600\Omega$ , $V_O = 0.15V$ to $4.85V$	92	100		dB
		$R_L = 10k\Omega$ , $V_O = 0.05V$ to $4.95V$	100	110		dB
$\Delta V_{OS}/\Delta T$	Input Offset Voltage Drift	$-40^\circ C \leq T_A \leq 125^\circ C$		2.7		$\mu V/^\circ C$
<b>OUTPUT CHARACTERISTICS</b>						
	Output Voltage Swing from Rail	$R_L = 600\Omega$ $-40^\circ C \leq T_A \leq 125^\circ C$			0.1	V
		$R_L = 10k\Omega$ $-40^\circ C \leq T_A \leq 125^\circ C$			0.015	
$I_{OUT}$	Output Current	$V_+ = 5V$	45	48		mA
$R_o$	Closed Loop Output Impedance	$F = 100kHz$ , $G = +1$		2.6		$\Omega$
<b>POWER-DOWN DISABLE</b>						
	Turn-On Time			6.2		nS
	Turn-Off Time			1.4		nS
	DISABLE Voltage Off				1.9	V
	DISABLE Voltage On		2			V
<b>POWER SUPPLY</b>						
	Operating Voltage Range		2.5		5.5	V
PSRR	Power Supply Rejection Ration		70	94		dB
$I_S$	Supply Current per Channel/Amp	$V_+ = 5V$ , $-40^\circ C \leq T_A \leq 125^\circ C$		350		$\mu A$
		$V_+ = 2.5V$ , $-40^\circ C \leq T_A \leq 125^\circ C$		320		
<b>DYNAMIC PERFORMANCE</b>						
GBP	Gain Bandwidth Product	$R_L = 10k\Omega$		6		MHz
SR	Slew Rate	$R_L = 600\Omega$ , $G = 1$ , 2V Output Step		3.6		V/ $\mu s$
$t_s$	Setting Time	$R_L = 600\Omega$ , $G = 1$ , 2V Output Step			1	$\mu s$
<b>NOISE PERFORMANCE</b>						
THD	Total Harmonic Distortion	$f = 10kHz$ , 1V Output Step, $R_L = 600\Omega$ and $100pF$		0.015		%
$e_n$	Voltage Noise Density	$f = 1kHz$ , $V_+ = 5V$		20		$nV/\sqrt{Hz}$
		$f = 10kHz$ , $V_+ = 5V$		12		

Specifications subject to change without notice.

Typical Application

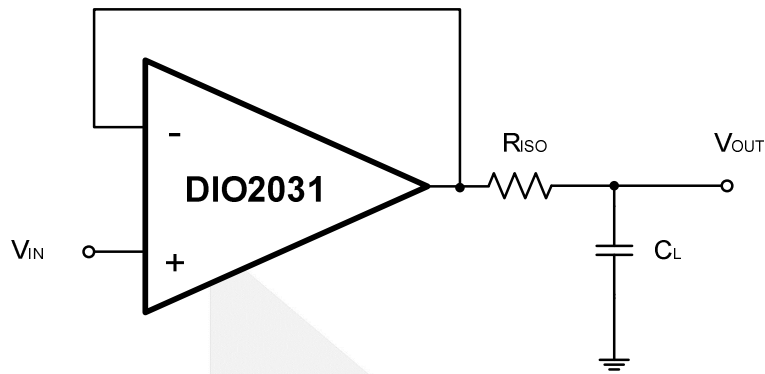

Figure 2 Indirectly Driving Heavy Capacitive Load

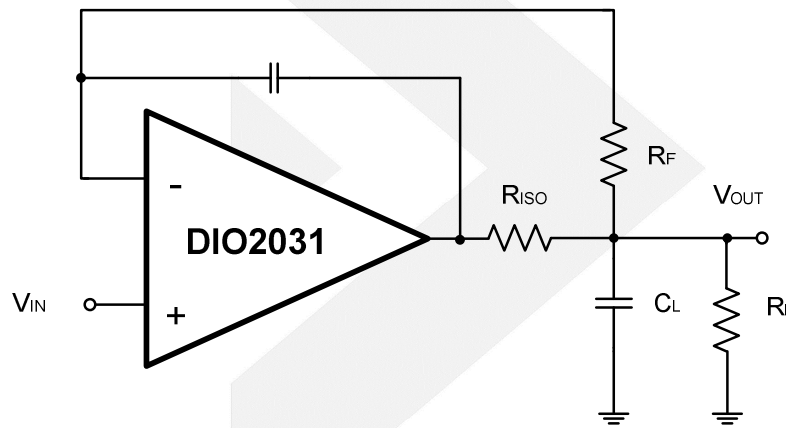

Figure 3 Indirectly Driving Heavy Capacitive Load with DC Accuracy

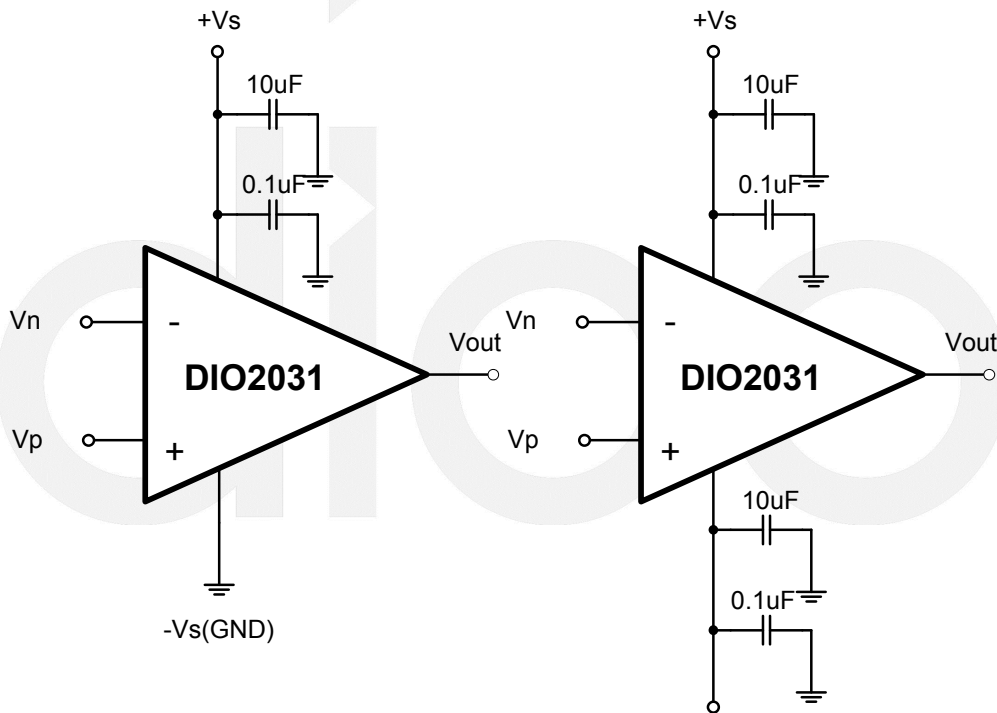
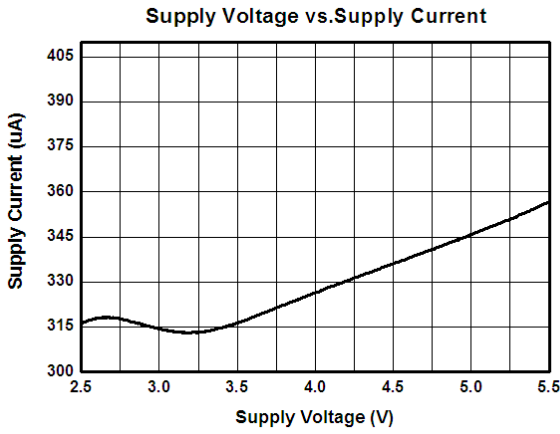

Figure 4 Amplifier with Bypass Capacitors

# Typical Performance Characteristics

Typical value:  $V_+ = 5V$ ,  $R_L = 100k\Omega$  to  $V_+/2$ ,  $T_A = 25^\circ C$ , unless otherwise specified.

Supply Voltage vs. Supply Current



Temperature vs. Supply Current

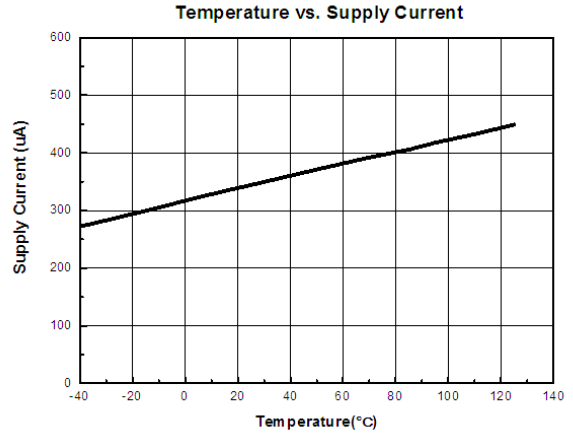

Input Voltage vs. Supply Current

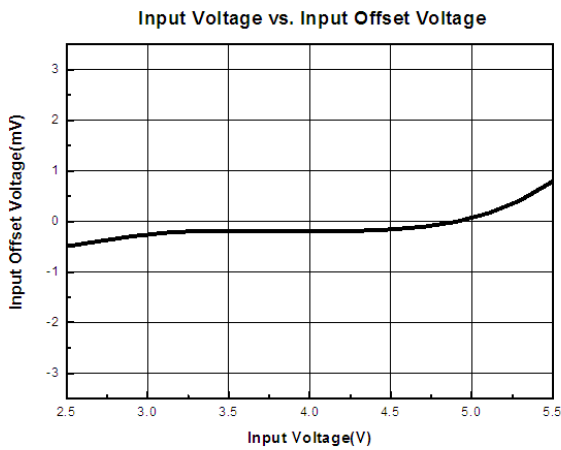

Common Mode Voltage vs. Input Offset Current

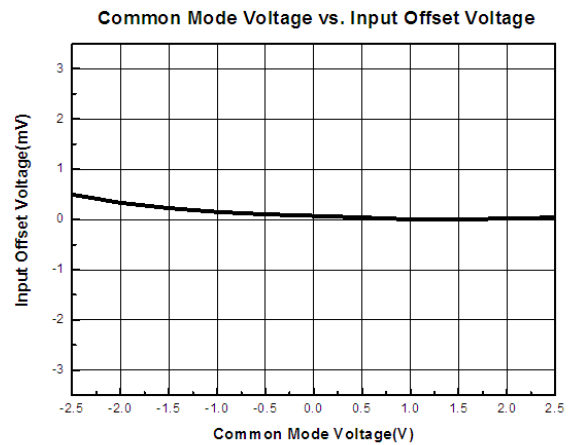

Temperature vs. Input Offset Voltage

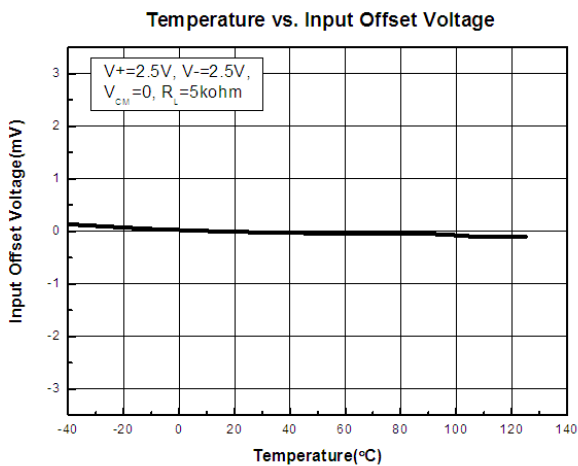

CMRR vs. Frequency

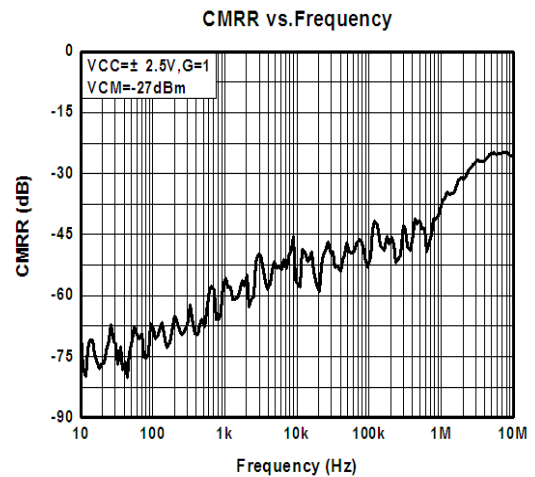



Maximum Output Voltage Swing vs. Frequency

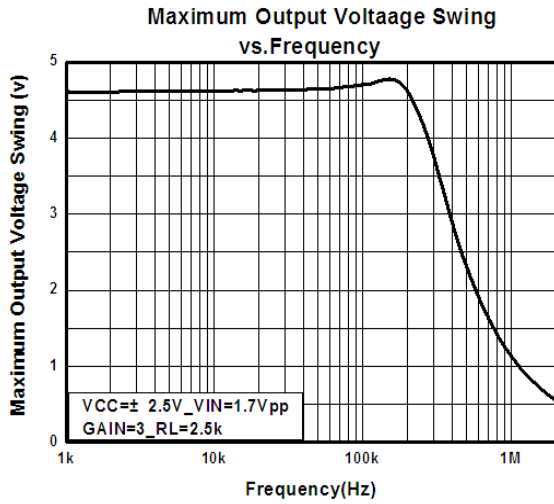

Maximum Output Voltage vs. Operating Voltage

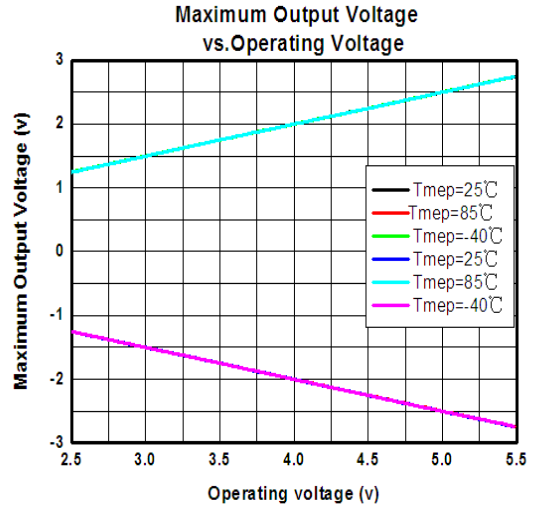

GBW vs. Frequency

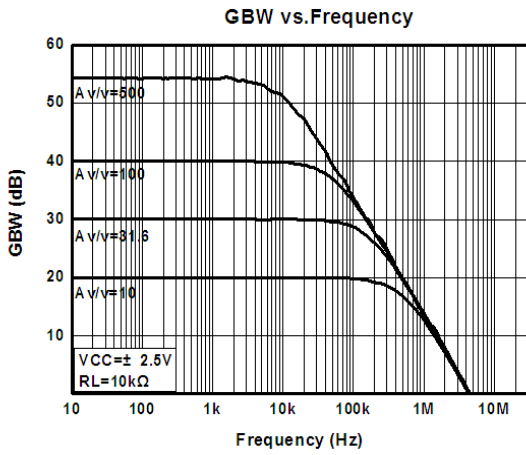

Slew Rate

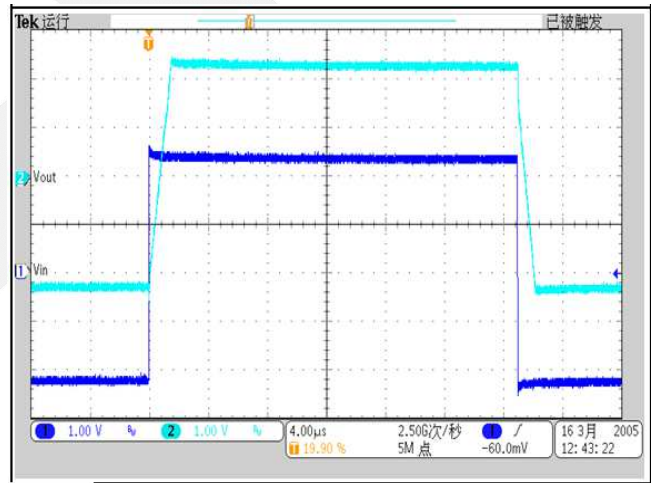

Over Load Recover(Positive)

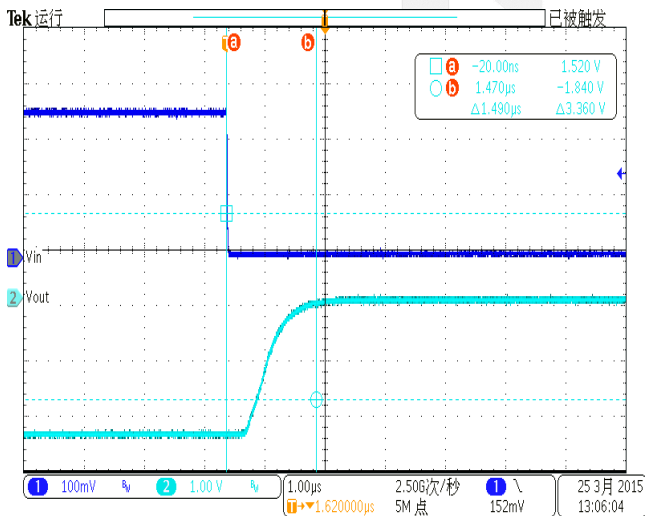

Over Load Recover(Negative)

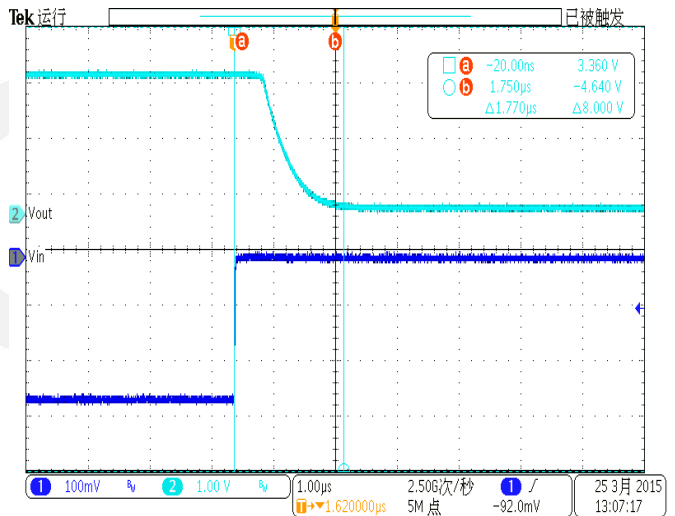

Physical Dimensions: SOT-23-5

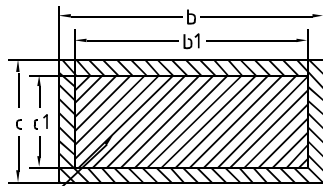
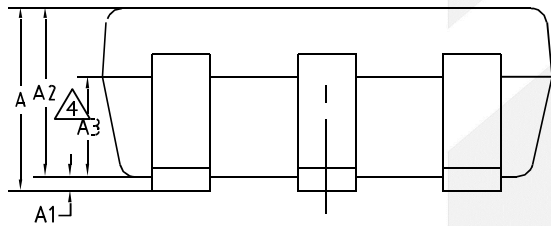
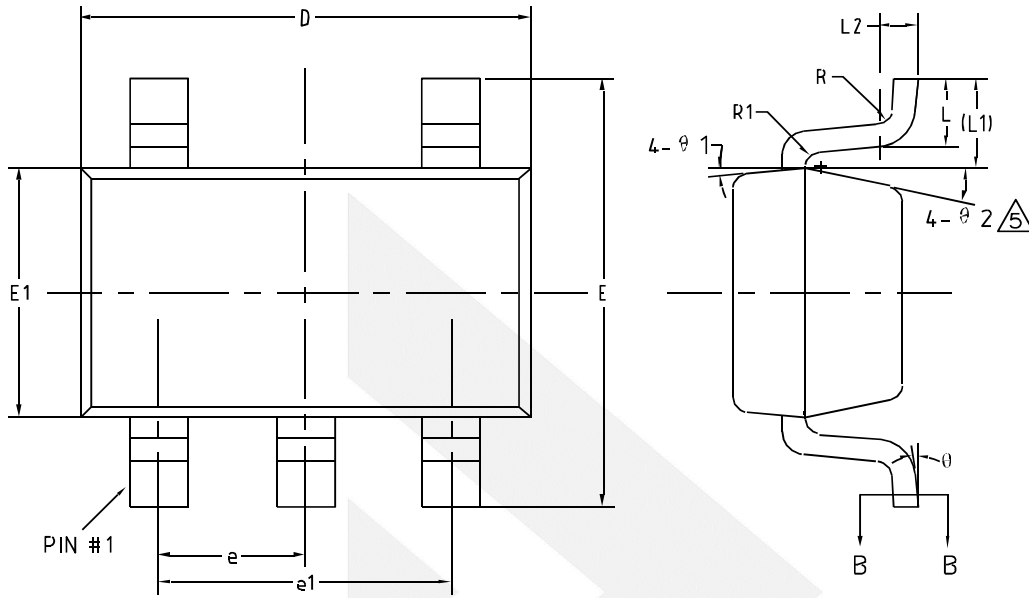

BASE METAL SECTION B-B

COMMON DIMENSIONS (UNITS OF MEASURE=MILLIMETER)			
Symbol	MIN	NOM	MAX
A	-	-	1.25
A1	0	-	0.15
A2	1.00	1.10	1.20
A3	0.60	0.65	0.70
b	0.36	-	0.50
b1	0.36	0.38	0.45
c	0.14	-	0.20
c1	0.14	0.15	0.16
D	2.826	2.926	3.026
E	2.60	2.80	3.00
E1	1.526	1.626	1.726
e	0.90	0.95	1.00
e1	1.80	1.90	2.00
L	0.35	0.45	0.60
L1	0.59REF		
L2	0.25BSC		
R	0.10	-	-
R1	0.10	-	0.25
θ	0°	-	8°
θ1	3°	5°	7°
θ2	6°	-	14°



Physical Dimensions: SOT-23-6

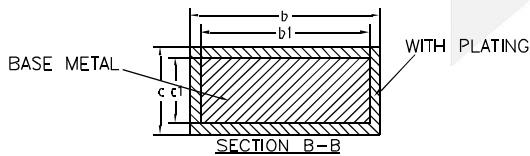
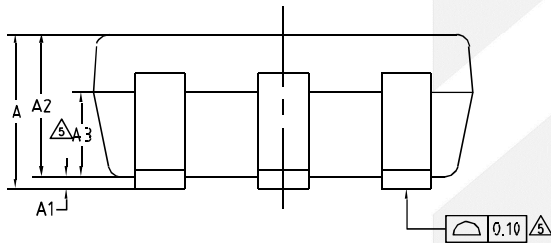
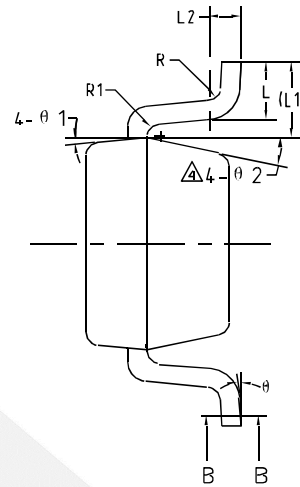
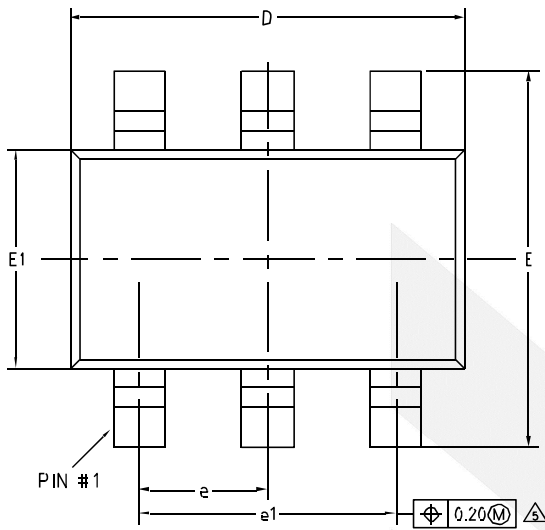

COMMON DIMENSIONS (UNITS OF MEASURE=MILLIMETER)			
Symbol	MIN	NOM	MAX
A	-	-	1.25
A1	0	-	0.15
A2	1.00	1.10	1.20
A3	0.60	0.65	0.70
b	0.36	-	0.50
b1	0.36	0.38	0.45
c	0.14	-	0.20
c1	0.14	0.15	0.16
D	2.826	2.926	3.026
E	2.60	2.80	3.00
E1	1.526	1.626	1.726
e	0.90	0.95	1.00
e1	1.80	1.90	2.00
L	0.35	0.45	0.60
L1	0.59REF		
L2	0.25BSC		
R	0.10	-	-
R1	0.10	-	0.25
θ	0°	-	8°
θ1	3°	5°	7°
θ2	6°	-	14°

Physical Dimensions: SOIC-8

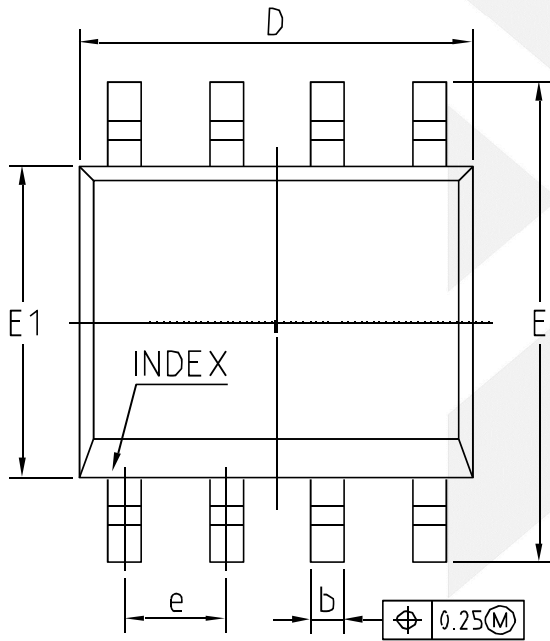
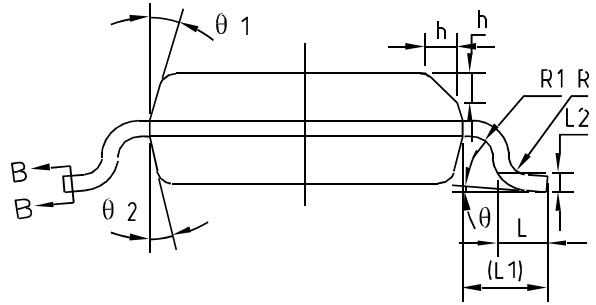
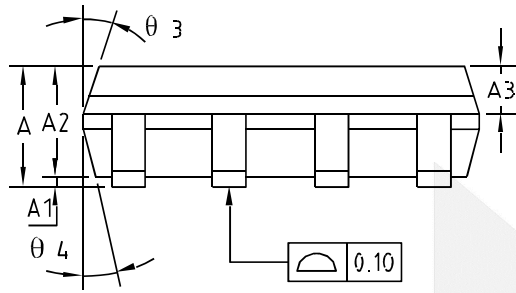

COMMON DIMENSIONS (UNITS OF MEASURE=MILLIMETER)			
Symbol	MIN	NOM	MAX
A	1.35	1.55	1.75
A1	0.10	0.15	0.25
A2	1.25	1.40	1.65
A3	0.50	0.60	0.70
b	0.38	-	0.51
b1	0.37	0.42	0.47
c	0.17	-	0.25
c1	0.17	0.20	0.23
D	4.80	4.90	5.00
E	5.80	6.00	6.20
E1	3.80	3.90	4.00
e	1.27BSC		
L	0.45	0.60	0.80
L1	1.04REF		
L2	0.25BSC		
R	0.07	-	-
R1	0.07	-	-
h	0.30	0.40	0.50
θ	0°	-	8°
θ1	15°	17°	19°
θ2	11°	13°	15°
θ3	15°	17°	19°
θ4	11°	13°	15°

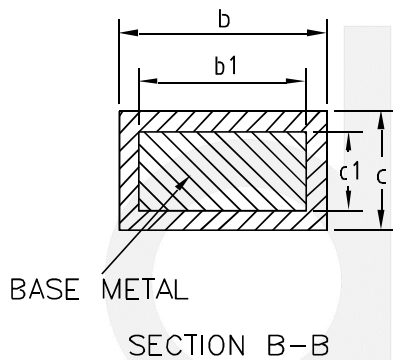

Physical Dimensions: MSOP-8

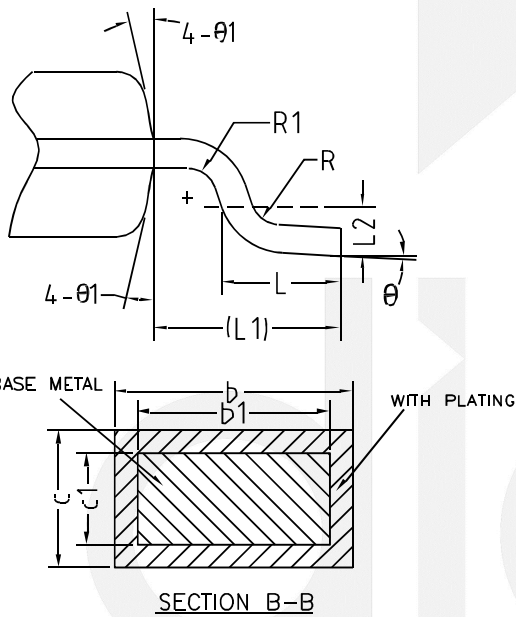
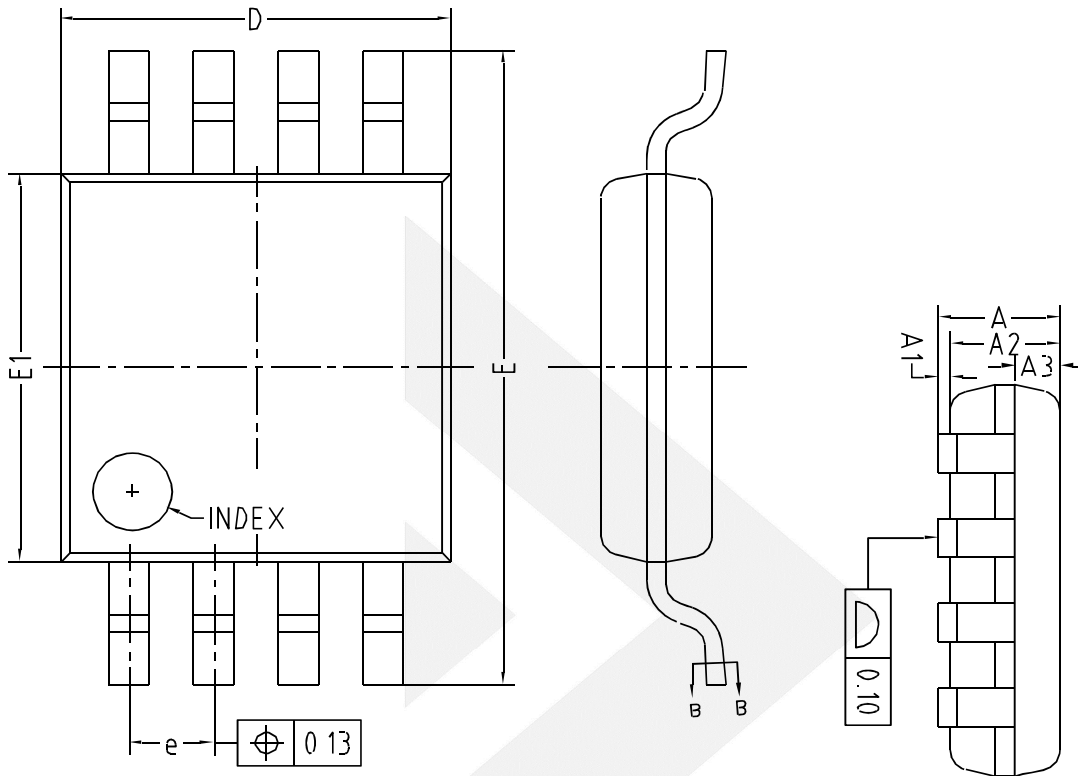

COMMON DIMENSIONS (UNITS OF MEASURE=MILLIMETER)			
Symbol	MIN	NOM	MAX
A	-	-	1.10
A1	0	-	0.15
A2	0.75	0.85	0.95
A3	0.25	0.35	0.39
b	0.28	-	0.37
b1	0.27	0.30	0.33
c	0.15	-	0.20
c1	0.14	0.15	0.16
D	2.90	3.00	3.10
E	4.70	4.90	5.10
E1	2.90	3.00	3.10
e	0.55	0.65	0.75
L	0.40	0.60	0.80
L1	0.95REF		
L2	0.25BSC		
R	0.07	-	-
R1	0.07	-	-
θ	0°	-	8°
θ1	9°	12°	15°

Physical Dimensions: TSSOP-8

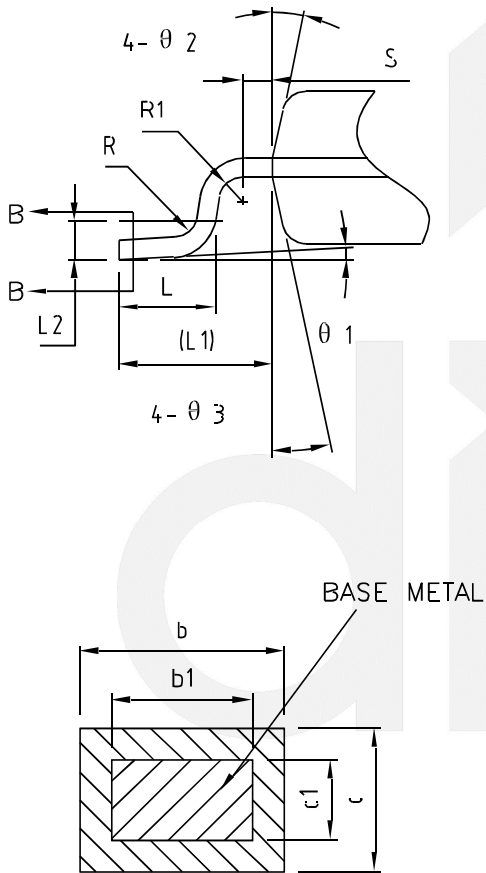
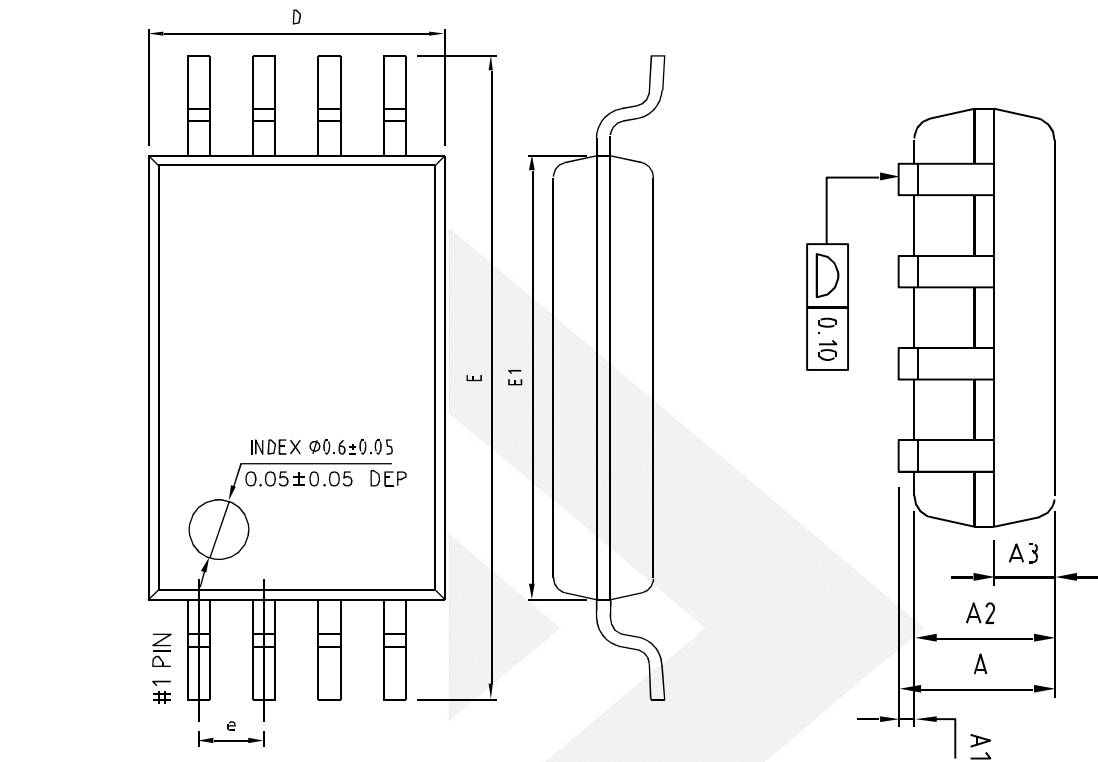

COMMON DIMENSIONS (UNITS OF MEASURE=MILLIMETER)			
Symbol	MIN	NOM	MAX
A	-	-	1.20
A1	0.05	-	0.15
A2	0.90	1.00	1.05
A3	0.34	0.44	0.54
b	0.20	-	0.28
b1	0.20	0.22	0.24
c	0.10	-	0.19
c1	0.10	0.13	0.15
D	2.83	2.93	3.03
E	6.20	6.40	6.60
E1	4.30	4.40	4.50
e	0.65BSC		
L	0.45	0.60	0.75
L1	1.00REF		
L2	0.25BSC		
R	0.09	-	-
R1	0.09	-	-
S	0.20	-	-
θ1	0°	-	8°
θ2	10°	12°	14°
θ3	10°	12°	14°

Physical Dimensions: TSSOP-14

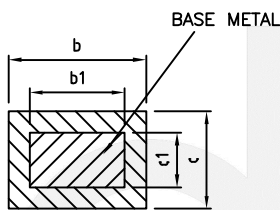
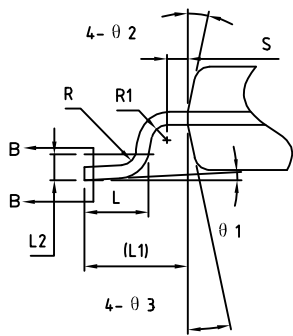
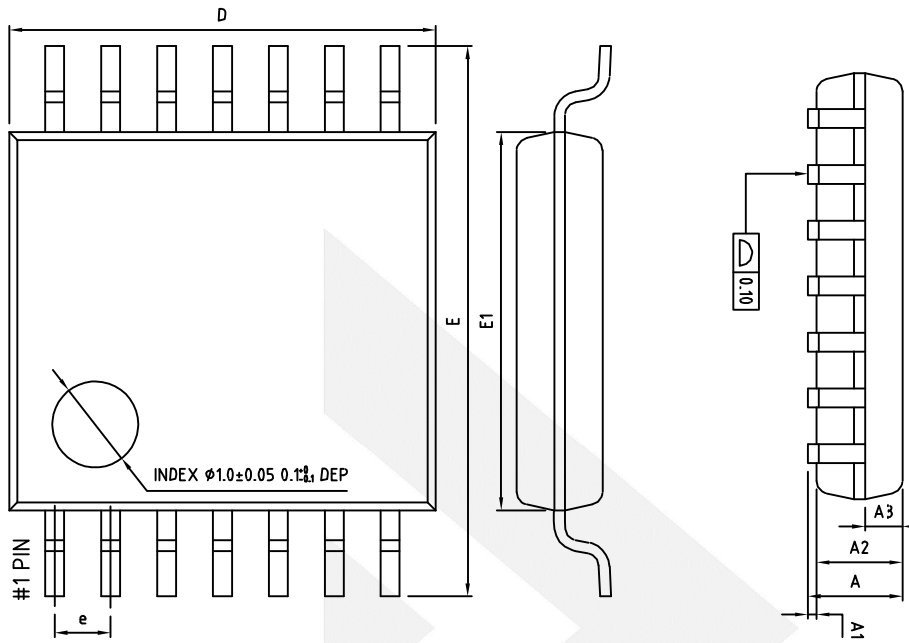

SECTION B-B

COMMON DIMENSIONS (UNITS OF MEASURE=MILLIMETER)			
Symbol	MIN	NOM	MAX
A	-	-	1.20
A1	0.05	-	0.15
A2	0.90	1.00	1.05
A3	0.34	0.44	0.54
b	0.20	-	0.28
b1	0.20	0.22	0.24
c	0.10	-	0.19
c1	0.10	0.13	0.15
D	4.86	4.96	5.06
E	6.20	6.40	6.60
E1	4.30	4.40	4.50
e	0.65BSC		
L	0.45	0.60	0.75
L1	1.00REF		
L2	0.25BSC		
R	0.09	-	-
R1	0.09	-	-
S	0.20	-	-
θ1	0°	-	8°
θ2	10°	12°	14°
θ3	10°	12°	14°

Physical Dimensions: SOIC-14

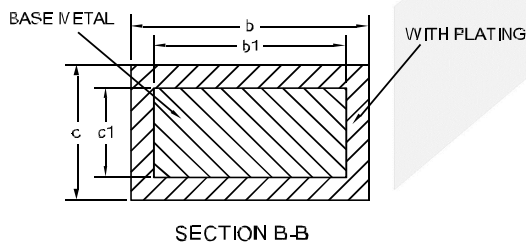
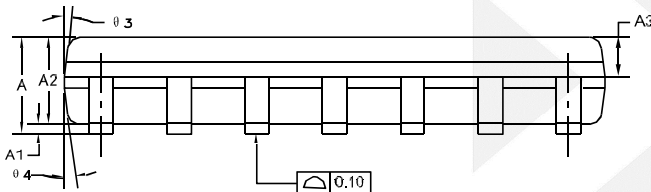
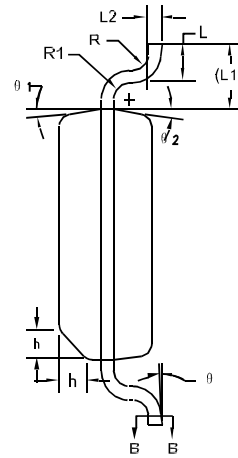
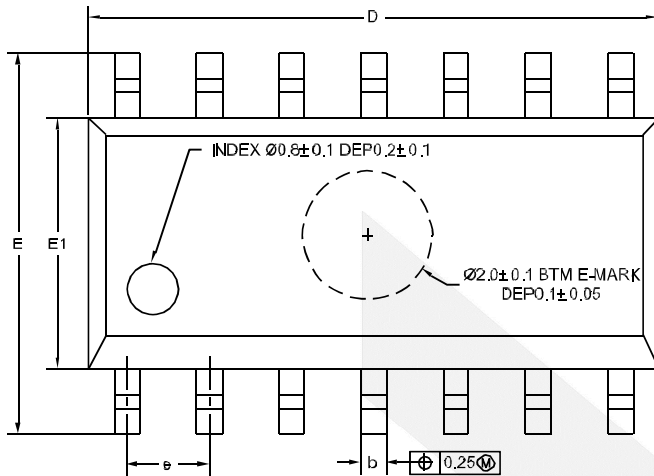

COMMON DIMENSIONS (UNITS OF MEASURE=MILLIMETER)			
Symbol	MIN	NOM	MAX
A	1.35	1.60	1.75
A1	0.10	0.15	0.25
A2	1.25	1.45	1.65
A3	0.55	0.65	0.75
b	0.36	-	0.49
b1	0.35	0.40	0.45
c	0.17	-	0.25
c1	0.17	0.20	0.23
D	8.53	8.63	8.73
E	5.80	6.00	6.20
E1	3.80	3.90	4.00
e	1.27BSC		
L	0.45	0.60	0.80
L1	1.04REF		
L2	0.25BSC		
R	0.07	-	-
R1	0.07	-	-
h	0.30	0.40	0.50
θ	0°	-	8°
θ1	6°	8°	10°
θ2	6°	8°	10°
θ3	5°	7°	9°
θ4	5°	7°	9°

Physical Dimensions: QFN-20

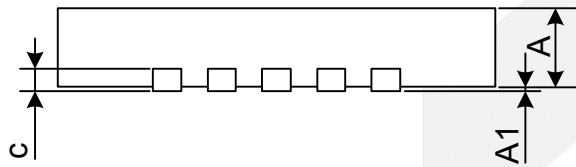
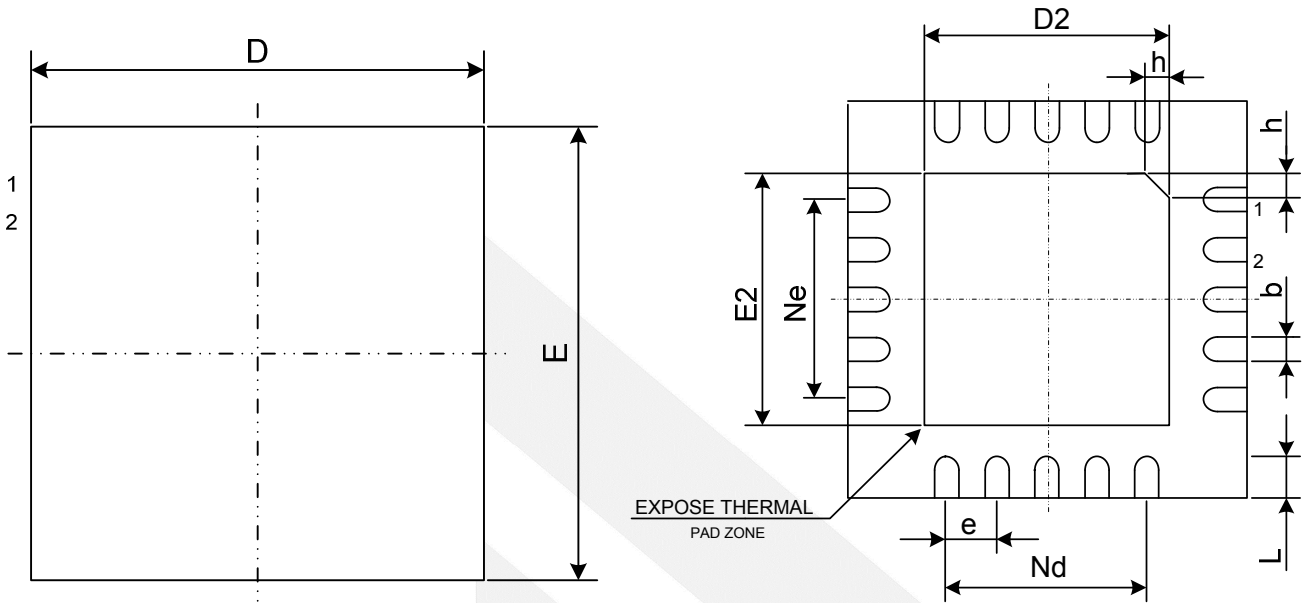

COMMON DIMENSIONS (UNITS OF MEASURE=MILLIMETER)			
Symbol	MIN	NOM	MAX
A	0.70	0.75	0.80
A1	-	0.02	0.05
b	0.18	0.25	0.30
c	0.18	0.20	0.25
D	3.90	4.00	4.10
D2	2.55	2.65	2.75
e	0.50BSC		
Ne	2.00BSC		
Nd	2.00BSC		
E	3.90	4.00	4.10
E2	2.55	2.65	2.75
L	0.35	0.40	0.45
h	0.30	0.35	0.40
L/F 载体尺寸 (mil)	114X114		



## CONTACT US

**Dioo** is a professional design and sales corporation for high-quality and performance analog semiconductors. The company focuses on industry markets, such as, cell phone, handheld products, laptop, and medical equipment and so on. Dioo's product families include analog signal processing and amplifying, LED drivers and charger IC. Go to <http://www.dioo.com> for a complete list of Dioo product families.

For additional product information, or full datasheet, please contact with our Sales Department or Representatives.



## X-ON Electronics

Largest Supplier of Electrical and Electronic Components

*Click to view similar products for [Operational Amplifiers - Op Amps](#) category:*

*Click to view products by [Dioo](#) manufacturer:*

Other Similar products are found below :

[OPA2991IDSGR](#) [OPA607IDCKT](#) [007614D](#) [633773R](#) [635798C](#) [635801A](#) [702115D](#) [709228FB](#) [741528D](#) [NCV33072ADR2G](#)  
[SC2902DTBR2G](#) [SC2903DR2G](#) [SC2903VDR2G](#) [LM258AYDT](#) [LM358SNG](#) [430227FB](#) [430228DB](#) [460932C](#) [AZV831KTR-G1](#) [409256CB](#)  
[430232AB](#) [LM2904DR2GH](#) [LM358YDT](#) [LT1678IS8](#) [042225DB](#) [058184EB](#) [070530X](#) [SC224DR2G](#) [SC239DR2G](#) [SC2902DG](#)  
[SCYA5230DR2G](#) [714228XB](#) [714846BB](#) [873836HB](#) [MIC918YC5-TR](#) [TS912BIYDT](#) [NCS2004MUTAG](#) [NCV33202DMR2G](#)  
[M38510/13101BPA](#) [NTE925](#) [SC2904DR2G](#) [SC358DR2G](#) [LM358EDR2G](#) [AZV358MTR-G1](#) [AP4310AUMTR-AG1](#) [HA1630D02MMEL-E](#)  
[NJM358CG-TE2](#) [HA1630S01LPEL-E](#) [LM324AWPT](#) [HA1630Q06TELL-E](#)