

DIO20721/1D/2/4

Single/Dual/Quad channel, RRIO 10MHz Amplifier

Features

- Rail-to-Rail Input and Output
- 0.5mV Typical offset (V_{OS})
- Low Distortion
- Gain Bandwidth Product: 10MHz
- Wide supply range: 2.5V to 5.5V
- 620 μ A/Amplifier typical supply current
- Slew rate: 6.5V/ μ s
- DIO20721 available in SC70-5, SOT23-5
DIO20721D available in SOT23-6
DIO20722 available in SOIC-8, MSOP-8 and TSSOP-8
DIO20724 available in SOIC-14, TSSOP-14

Applications

- Portable Equipment
- Active Filters
- Data Acquisition
- Portable Equipment
- Test Equipment
- Broadband Communication
- Process Control
- Audio and Video Processing

Ordering Information

Order Part Number	Top Marking		T_A	Package		
DIO20721SC5	YWXX	Green/RoH	-40 to 125°C	SC70-5	MSL3	Tape & Reel, 3000
DIO20721ST5	YWXX	Green/RoH	-40 to 125°C	SOT23-5	MSL3	Tape & Reel, 3000
DIO20721DST6	YWDK	Green/RoH	-40 to 125°C	SOT23-6	MSL3	Tape & Reel, 3000
DIO20722MP8	DIO2072	Green/RoH	-40 to 125°C	MSOP-8	MSL3	Tape & Reel, 3000
DIO20722SO8	DIO2072	Green/RoH	-40 to 125°C	SOIC-8	MSL3	Tape & Reel, 2500
DIO20722TP8	DIO2072	Green/RoH	-40 to 125°C	TSSOP-8	MSL3	Tape & Reel, 3000
DIO20724CS14	DIO2074	Green/RoH	-40 to 125°C	SOIC-14	MSL3	Tape & Reel, 2500
DIO20724TP14	DIO2074	Green/RoH	-40 to 125°C	TSSOP-14	MSL3	Tape & Reel, 2500

Descriptions

The DIO2072x is a single/dual/quad channel, rail-to-rail I/O operational amplifier which allows low load impedances to be driven. With a 10MHz unity-gain frequency and low noise, low distortion and high output current capability, the DIO2072x provides excellent choice for high quality systems. The input common-mode voltage range includes ground, and the maximum input offset voltage is 0.5mV (guaranteed). They are also capable of comfortably driving large capacitive loads.

DIO2072x is offered in Green or RoHS package and ESD (HBM) exceeds 2kV. It is specified over the extended -40 to 125°C.

Typical Application

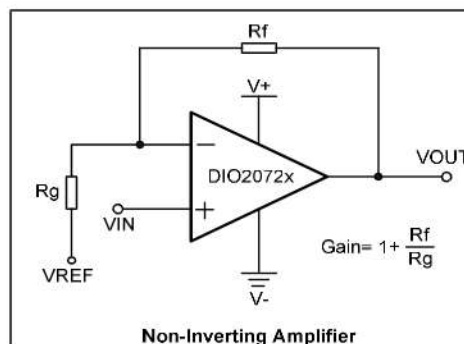

Pin Assignments

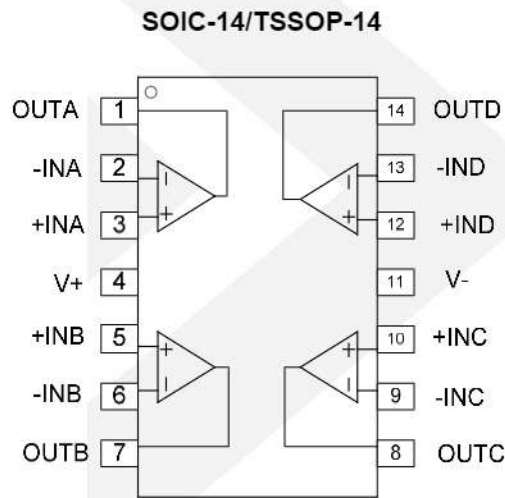
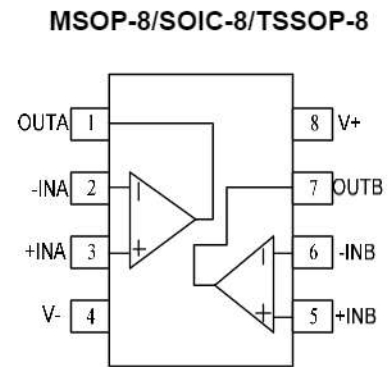
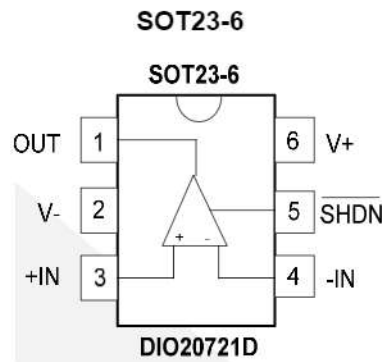
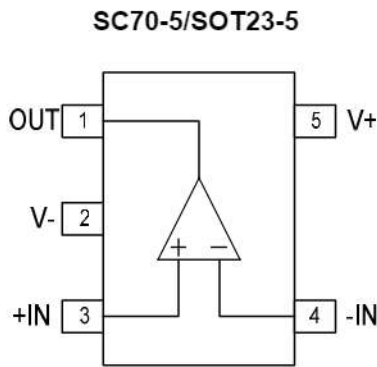

Figure 1 Top View

Pin Description

Pin name	Description
V+	Positive supply
V-	Negative supply
+INx (+INA,+INB,+INC,+IND,)	Positive Input (channel A,B,C,D)
-INx (-INA,-INB,-INC,-IND)	Negative Input (channel A,B,C,D)
OUTx (OUTA,OUTB,OUTC,OUTD)	Output (channel A,B,C,D)
SHDN	Active Low Shutdown



DIO20721/1D/2/4

Single/Dual/Quad channel RRIO 10MHz Amplifier

Absolute Maximum Ratings

Stresses beyond those listed under "Absolute Maximum Rating" may cause permanent damage to the device. These are stress ratings only and functional operation of the device at these or any other condition beyond those indicated in the operational sections of the specifications is not implied. Exposure to absolute maximum rating conditions for extended periods may affect device reliability.

Parameter		Rating	Unit
Supply Voltage		7	V
Input Voltage		(V-)0.5 to 7	V
Storage Temperature Range		-65 to 150	°C
Junction Temperature		150	°C
Lead Temperature Range		260	°C
ESD	HBM, JEDEC: JESD22-A114	2	kV
	CDM, JEDEC: JESD22-C101	1	

Recommended Operating Conditions

The Recommended Operating Conditions table defines the conditions for actual device operation to ensure optimal performance to the datasheet specifications. DIOO does not recommend exceeding them or designing to Absolute Maximum Ratings.

Parameter		Rating	Unit
Supply Voltage		2.5 to 5.5	V
Input Voltage		0 to 5	V
Operating Temperature Range		-40 to 125	°C





DIO20721/1D/2/4

Single/Dual/Quad channel RRIO 10MHz Amplifier

Electrical Characteristics

Typical value: $V_{+}=5V/2.5V$, $V_{CM}=V_{+}/2$, $R_L=600\ \Omega$, $T_A = 25^{\circ}C$, unless otherwise specified.

Symbol	Parameter	Conditions	Min.	Typ.	Max.	Unit
INPUT CHARACTERISTICS						
V_{OS}	Input Offset Voltage	$-40^{\circ}C \leq T_A \leq 125^{\circ}C$, $V_{+}=2.5V$ to $5V$	-5.0	0.5	5.0	mV
I_B	Input Bias Current	$-40^{\circ}C \leq T_A \leq 125^{\circ}C$, $V_{+}=2.5V$ to $5V$		1.0		pA
I_{OS}	Input Offset Current	$-40^{\circ}C \leq T_A \leq 125^{\circ}C$, $V_{+}=2.5V$ to $5V$		1.0		pA
V_{CM}	Common Mode Voltage Range		-0.1		(V+) +0.1	V
CMRR	Common Mode Rejection Ratio	$-40^{\circ}C \leq T_A \leq 125^{\circ}C$, $V_{CM}=-0.1$ to $(V_{+})+0.1$, $V_{+}=5V$	75	90		dB
A_{OL}	Open Loop Voltage Gain	$R_L=600\Omega$, $V_o=0.1$ to $(V_{+})-0.1$	100	130		dB
$\Delta V_{OS}/\Delta T$	Input Offset Voltage Drift	$-40^{\circ}C \leq T_A \leq 125^{\circ}C$			2.0	$\mu V/^{\circ}C$
OUTPUT CHARACTERISTICS						
	Output Voltage Swing from Rail	$R_L=600\Omega$ $-40^{\circ}C \leq T_A \leq 125^{\circ}C$		0.1		V
		$R_L=10k\Omega$ $-40^{\circ}C \leq T_A \leq 125^{\circ}C$		0.015		
I_{OUT}	Output Current	$V_{+}=5V$	80	85		mA
		$V_{+}=2.5V$	20	27		
	Closed Loop Output Impedance	$F=1MHz$, $G=+1$, $V_{+}=5V$		2.8		Ω
		$F=1MHz$, $G=+1$, $V_{+}=2.5V$		4.4		
POWER SUPPLY						
PSRR	Power Supply Rejection Ration		75	110		dB
I_{SHDN}	Shutdown Pin Current			-10		pA
I_S	Supply Current per Channel/Amp	$V_{+}=5V$, $-40^{\circ}C \leq T_A \leq 125^{\circ}C$	480	620	870	μA
		$V_{+}=2.5V$, $-40^{\circ}C \leq T_A \leq 125^{\circ}C$	450	590	830	
I_{LEAK}	Output Leakage Current in Shutdown	$V_{SHDN}=0V$		3.6		pA
V_{IL}	SHDN Input Low Voltage	Disable			0.5	V
V_{IH}	SHDN Input High Voltage	Enable	1.1			V
DYNAMIC PERFORMANCE						
GBP	Gain Bandwidth Product			10.0		MHz
SR	Slew Rat	$G=1$, 2V Output Step		6.5		V/ μs
t_s	Setting Time	$G=1$, 2V Output Step		0.25		μs
X_{talk}	Channel Separation	$F=1kHz$, $R_L=10k\Omega$		110		dB
	Overload Recovery Time	$V_{IN} \cdot Gain=V_{+}$		1.0		μs
NOISE PERFORMANCE						
THD	Total Harmonic Distortion	$f=10kHz$, 2V Output Step, $R_L=600\Omega$, $V_{+}=5V$		0.04		%
e_n	Voltage Noise Density	$f=1kHz$, $V_{+}=5V$		28		nV/ \sqrt{Hz}
		$f=10kHz$, $V_{+}=5V$		20		



DIO20721/1D/2/4

Single/Dual/Quad channel RRIO 10MHz Amplifier

Typical Performance Characteristics

Supply Current vs. Supply Voltage Per Channel

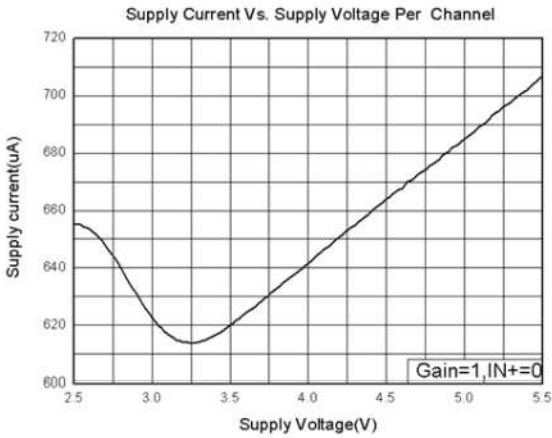

Supply Current vs. Temperature

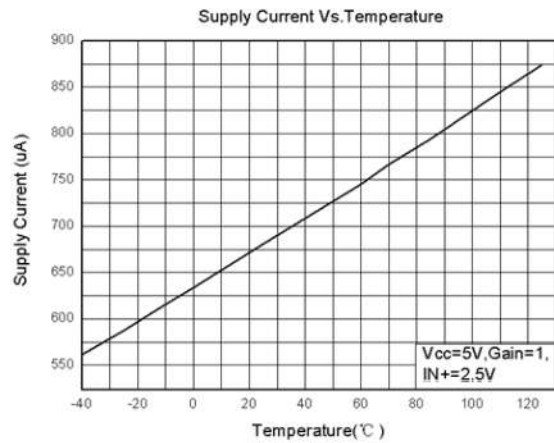

I_{SOURCE} vs. Output Voltage

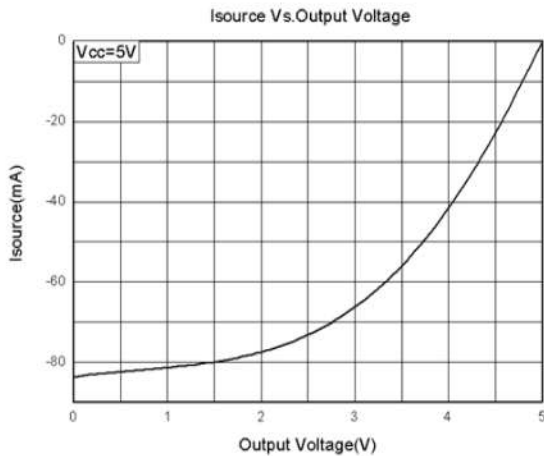

I_{SINK} vs. Output Voltage

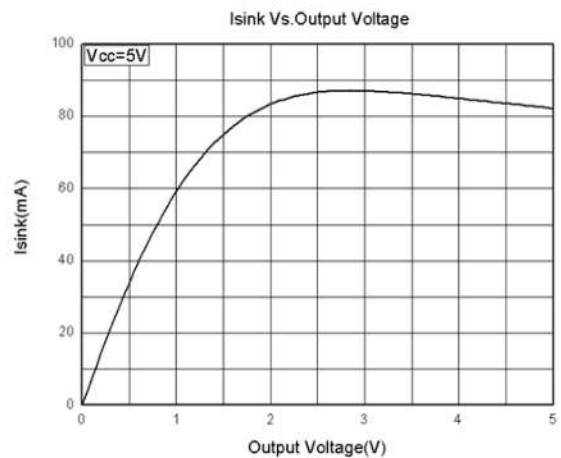

I_{SINK} vs. Output Voltage

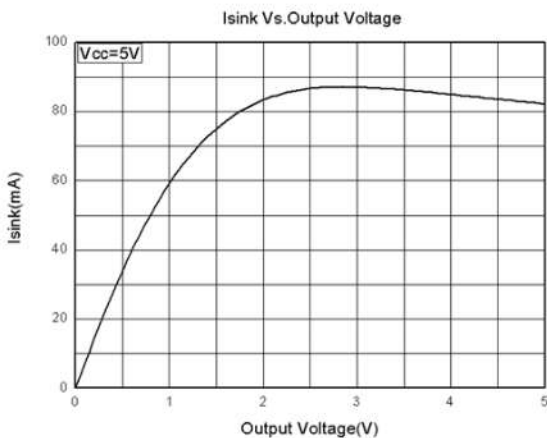

Input Offset Voltage vs. Temperature

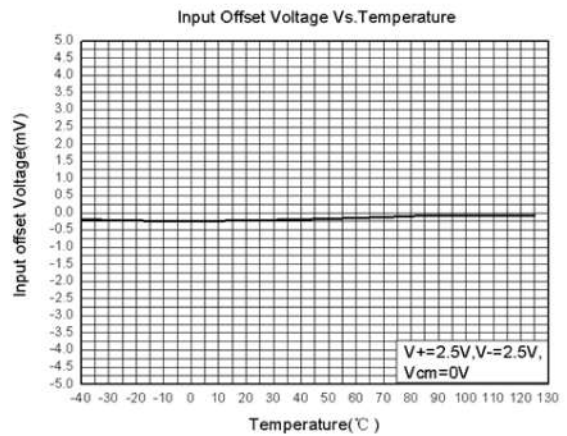



DIO20721/1D/2/4

Single/Dual/Quad channel RRIO 10MHz Amplifier

Input Offset Voltage vs. Supply Voltage

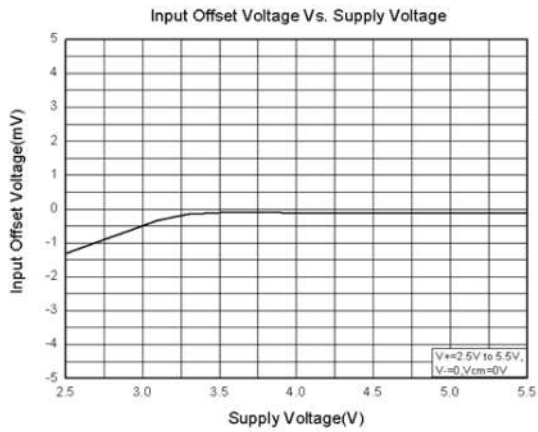

Input Offset Voltage vs. Common Voltage

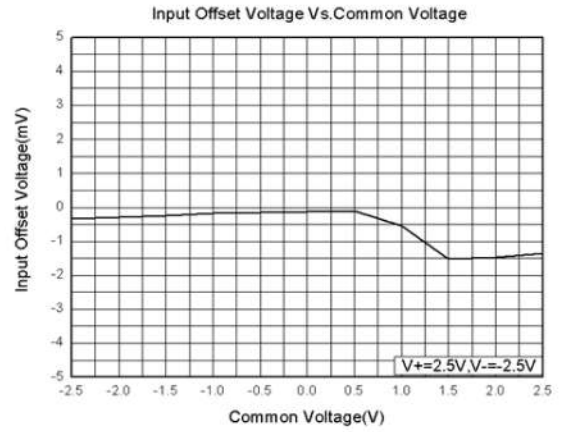

Large-Signal Response ($V+=5V$, $R_L=1M\Omega$)

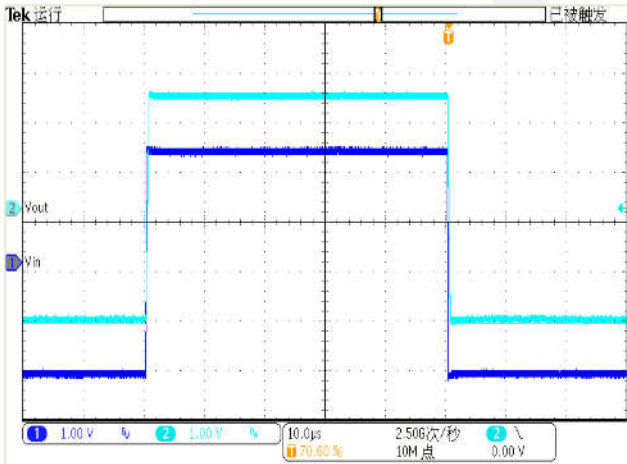



DIO20721/1D/2/4

Single/Dual/Quad channel RRIO 10MHz Amplifier

CONTACT US

Dioo is a professional design and sales corporation for high-quality and performance analog semiconductors. The company focuses on industry markets, such as, cell phone, handheld products, laptop, and medical equipment and so on. Dioo's product families include analog signal processing and amplifying, LED drivers and charger IC. Go to <http://www.dioo.com> for a complete list of Dioo product families.

For additional product information, or full datasheet, please contact with our Sales Department or Representatives.



X-ON Electronics

Largest Supplier of Electrical and Electronic Components

Click to view similar products for [Operational Amplifiers - Op Amps](#) category:

Click to view products by [Dioo](#) manufacturer:

Other Similar products are found below :

[OPA2991IDSGR](#) [OPA607IDCKT](#) [007614D](#) [633773R](#) [635798C](#) [635801A](#) [702115D](#) [709228FB](#) [741528D](#) [NCV33072ADR2G](#)
[SC2902DTBR2G](#) [SC2903DR2G](#) [SC2903VDR2G](#) [LM258AYDT](#) [LM358SNG](#) [430227FB](#) [430228DB](#) [460932C](#) [AZV831KTR-G1](#) [409256CB](#)
[430232AB](#) [LM2904DR2GH](#) [LM358YDT](#) [LT1678IS8](#) [042225DB](#) [058184EB](#) [070530X](#) [SC224DR2G](#) [SC239DR2G](#) [SC2902DG](#)
[SCYA5230DR2G](#) [714228XB](#) [714846BB](#) [873836HB](#) [MIC918YC5-TR](#) [TS912BIYDT](#) [NCS2004MUTAG](#) [NCV33202DMR2G](#)
[M38510/13101BPA](#) [NTE925](#) [SC2904DR2G](#) [SC358DR2G](#) [LM358EDR2G](#) [AZV358MTR-G1](#) [AP4310AUMTR-AG1](#) [HA1630D02MMEL-E](#)
[NJM358CG-TE2](#) [HA1630S01LPEL-E](#) [LM324AWPT](#) [HA1630Q06TELL-E](#)