

## DIO2087X

### Micro-power CMOS input RRIO 1.4V Push-Pull Output Comparator

#### Features

- Ultra Low Power Consumption:  
1.35 $\mu$ A (TYP) at V+ = 1.4V
- Wide Supply Voltage Range: 1.4V to 5.5V
- Propagation Delay: 1.3 $\mu$ s (TYP) at V+ = 1.4V
- Push-Pull Output Current Drive:  
25mA (TYP) at V+ = 5V
- Rail-to-Rail Input
- -40°C to 85°C Operating Temperature Range
- Available in the Green SOT23-5, SC70-5,  
SOIC-8, MSOP-8, SOP-14 and TSSOP-14  
Packages

#### Applications

- RC Timers
- Window Detectors
- IR Receiver
- Multivibrators
- Alarm and Monitoring Circuits

#### Descriptions

The DIO2087X is an ultra low-power comparator with a typical power supply current of 1.35 $\mu$ A. It has the best-in-class power supply current versus propagation delay performance. The propagation delay is as low as 1.3 $\mu$ s with 100mV overdrive at 1.4V supply.

Designed to operate over a wide range of supply voltages, from 1.4V to 5.5V, with guaranteed operation at 1.4V, 2.5V and 5.0V, the DIO2087X is ideal for use in a variety of battery-powered applications. With rail-to-rail common mode voltage range, the DIO2087X is well suited for single-supply operation.

Featuring a push-pull output stage, the DIO2087X allows for operation with absolute minimum power consumption when driving any capacitive or resistive load.

DIO2087X is available in the Green SOT23-5, SC70-5, SOIC-8, MSOP-8, SOP-14 and TSSOP-14 packages. The DIO2087X is ideal for use in handheld electronics and mobile phone applications. It is rated over the -40°C to 85°C temperature range

#### Ordering Information

Order Part Number	Top Marking		T <sub>A</sub>	Package	
DIO20871ST5	YW71	Green	-40 to 85°C	SOT23-5	Tape & Reel, 3000
DIO20871SC5	YW71	Green	-40 to 85°C	SC70-5	Tape & Reel, 3000
DIO20871ASC5	W71A	Green	-40 to 85°C	SC70-5	Tape & Reel, 3000
DIO20871AST5	W71A	Green	-40 to 85°C	SOT23-5	Tape & Reel, 3000
DIO20872SO8	D20872	Green	-40 to 85°C	SOIC-8	Tape & Reel, 2500
DIO20872MP8	D20872	Green	-40 to 85°C	MSOP-8	Tape & Reel, 3000
DIO20874CS14	D20874	Green	-40 to 85°C	SOP-14	Tape & Reel, 2500
DIO20874TP14	D20874	Green	-40 to 85°C	TSSOP-14	Tape & Reel, 2500
DIO20875SO8	D20875	Green	-40 to 85°C	SOIC-8	Tape & Reel, 2500
DIO20875MP8	D20875	Green	-40 to 85°C	MSOP-8	Tape & Reel, 3000

## Pin Assignments

**DIO20871**

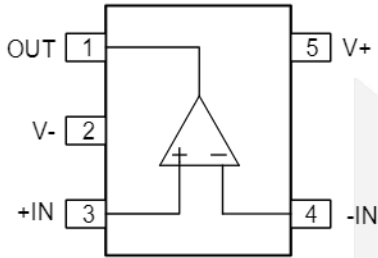

**SOT23-5/SC70-5**

**DIO20871A**

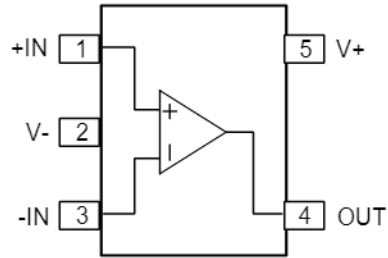

**SOT23-5/SC70-5**

**DIO20872**

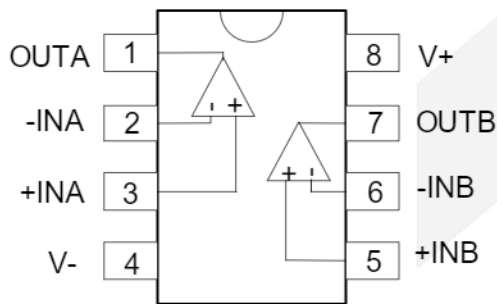

**SOIC-8/MSOP-8**

**DIO20874**

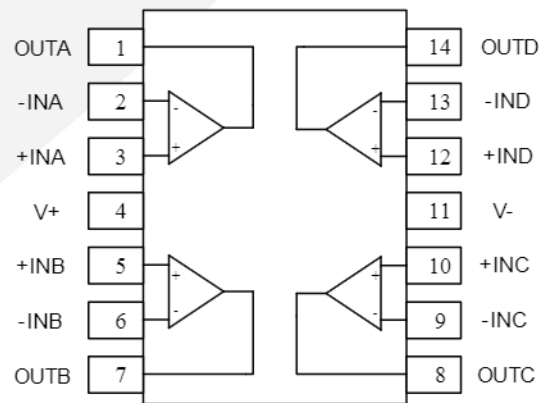

**SOP-14/TSSOP-14**

**DIO20875**

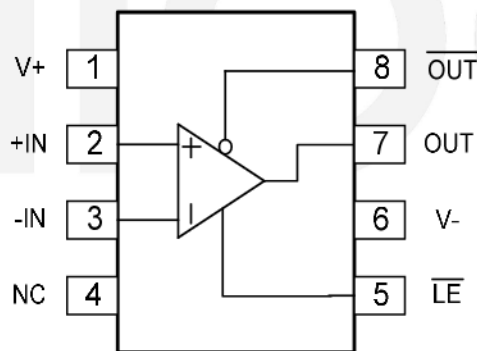

**SOIC-8/MSOP-8**

**Figure 1 Pin Assignment (Top View)**

## Pin Description

Pin name	Description
OUTX	Output
V-	Negative supply
+INX	Positive Input
-INX	Negative Input
V+	Positive supply
$\overline{LE}$	Enable
$\overline{OUT}$	Negative Output
NC	No Connect

## Absolute Maximum Ratings

Stresses beyond those listed under “Absolute Maximum Rating” may cause permanent damage to the device. These are stress ratings only and functional operation of the device at these or any other condition beyond those indicated in the operational sections of the specifications is not implied. Exposure to absolute maxim rating conditions for extended periods may affect device reliability.

Parameter	Rating	Unit
Supply Voltage ( V+ – V-)	7.5	V
Input Voltage	(V-)-0.5V to (V+)+0.5V	V
Difference Input Voltage	±2.5V	V
Operating Temperature Range (T <sub>A</sub> )	-40 to 85	°C
Storage Temperature Range (T <sub>STO</sub> )	-55 to 150	°C
Junction Temperature (T <sub>J</sub> )	160	°C
Lead Temperature Range	260	°C
ESD	HBM, JEDEC: JESD22-A114	4000
	CDM, JEDEC: JESD22-C101	400

## Recommended Operating Conditions

The Recommended Operating Conditions table defines the conditions for actual device operation to ensure optimal performance to the datasheet specifications. DIOO does not recommend exceeding them or designing to Absolute Maximum Ratings.

Parameter	Rating	Unit
Supply Voltage	1.4 to 5.5	V
Operating Temperature Range	-40 to 85	°C

## Electrical Characteristics: $V_+ = 1.4V$

(At  $T_A = 25^\circ C$ ,  $V_+ = 1.4V$ ,  $V_- = 0V$ ,  $V_{LE} = 1.4V$ ,  $V_{CM} = V_+/2$  and  $V_O = V_-$ , unless otherwise noted.)

Parameter	Symbol	Condition	MIN	TYP	MAX	Unit
Supply Current	$I_S$	$-40^\circ C \leq T_A \leq 85^\circ C$ , $V_{CM} = 0.3V$		1.20		$\mu A$
		$-40^\circ C \leq T_A \leq 85^\circ C$ , $V_{CM} = 1.1V$		1.35		
Input Offset Voltage	$V_{OS}$		-5	0	5	mV
Input Offset Average Drift	$\Delta V_{OS}/\Delta T$			2.7		$\mu V/^\circ C$
Common Mode Rejection Ratio	CMRR	$V_{CM}$ Stepped from 0V to 0.3V		60		dB
		$V_{CM}$ Stepped from 0.8V to 1.4V		78		
		$V_{CM}$ Stepped from 0V to 1.4V		68		
Power Supply Rejection Ratio	PSRR	$V_+ = 2.5V$ to $5.5V$ , $V_{CM} = (-V_+) + 0.5V$		80		dB
Latch Enable Pin High Input Voltage	$V_{IH}$			0.85		V
Latch Enable Pin Low Input Voltage	$V_{IL}$			0.5		V
Latch Enable Pin Bias Current	$I_{IL}$	$V_{LE} = 0V$		7.5		nA
Output Swing High	$V_{OH}$	$V_+ = 1.8V$ , $I_O = 500\mu A$		1.65		V
		$V_+ = 1.8V$ , $I_O = 1mA$		1.55		
Output Swing Low	$V_{OL}$	$V_+ = 1.8V$ , $I_O = -500\mu A$		100		mV
		$V_+ = 1.8V$ , $I_O = -1mA$		200		
Output Current	$I_{OUT}$	Source		0.98		mA
		Sink		1.38		
Propagation Delay (High to Low)		Overdrive = 10mV		3.5		$\mu s$
		Overdrive = 100mV		1.1		
Propagation Delay (Low to High)		Overdrive = 10mV		2.2		$\mu s$
		Overdrive = 100mV		1.4		
Rise Time	$t_{Rise}$	Overdrive = 10mV, $C_L = 30pF$ , $R_L = 1M\Omega$		160		ns
		Overdrive = 100mV, $C_L = 30pF$ , $R_L = 1M\Omega$		160		
Fall Time	$t_{Fall}$	Overdrive = 10mV, $C_L = 30pF$ , $R_L = 1M\Omega$		160		ns
		Overdrive = 100mV, $C_L = 30pF$ , $R_L = 1M\Omega$		160		

## ELECTRICAL CHARACTERISTICS: $V_+ = 2.5V$

(At  $T_A = 25^\circ C$ ,  $V_+ = 2.5V$ ,  $V_- = 0V$ ,  $V_{LE} = 2.5V$ ,  $V_{CM} = V_+/2$  and  $V_O = V_-$ , unless otherwise noted.)

Parameter	Symbol	Condition	MIN	TYP	MAX	Unit
Supply Current	$I_S$	$-40^\circ C \leq T_A \leq 85^\circ C$ , $V_{CM} = 0.3V$		1.25		$\mu A$
		$-40^\circ C \leq T_A \leq 85^\circ C$ , $V_{CM} = 2.2V$		1.4		
Input Offset Voltage	$V_{OS}$		-5	0	5	mV
Input Offset Average Drift				2		$\mu V/^\circ C$
Common Mode Rejection Ratio	CMRR	$V_{CM}$ Stepped from 0V to 1.4V		77		dB
		$V_{CM}$ Stepped from 1.9V to 2.5V		85		
		$V_{CM}$ Stepped from 0V to 2.5V		77		
Power Supply Rejection Ratio	PSRR			90		dB
Latch Enable Pin High Input Voltage	$V_{IH}$			1.4		V
Latch Enable Pin Low Input Voltage	$V_{IL}$			0.9		V
Latch Enable Pin Bias Current	$I_{IL}$	$V_{LE} = 0V$		13.		nA
Large Signal Voltage Gain	$A_{VO}$			90		dB
Output Swing High	$V_{OH}$	$I_O = 500\mu A$		2.4		V
		$I_O = 1mA$		2.3		
Output Swing Low	$V_{OL}$	$I_O = -500\mu A$		60		mV
		$I_O = -1mA$		120		
Output Current	$I_{OUT}$	Source		5.8		mA
		Sink		7.1		
Propagation Delay (High to Low)		Overdrive = 10mV		2.8		$\mu s$
		Overdrive = 100mV		0.95		
Propagation Delay (Low to High)		Overdrive = 10mV		2.00		$\mu s$
		Overdrive = 100mV		1.10		
Rise Time	$t_{Rise}$	Overdrive = 10mV, $C_L = 30pF$ , $R_L = 1M\Omega$		80		ns
		Overdrive = 100mV, $C_L = 30pF$ , $R_L = 1M\Omega$		50		
Fall Time	$t_{Fall}$	Overdrive = 10mV, $C_L = 30pF$ , $R_L = 1M\Omega$		80		ns
		Overdrive = 100mV, $C_L = 30pF$ , $R_L = 1M\Omega$		50		

## ELECTRICAL CHARACTERISTICS: $V_+ = 5.0V$

(At  $T_A = 25^\circ C$ ,  $V_+ = 5.0V$ ,  $V_- = 0V$ ,  $V_{LE} = 5.0V$ ,  $V_{CM} = V_+/2$  and  $V_O = V_-$ , unless otherwise noted.)

Parameter	Symbol	Conditions	MIN	TYP	MAX	Unit
Supply Current	$I_S$	$-40^\circ C \leq T_A \leq 85^\circ C$ , $V_{CM} = 0.3V$		1.35		$\mu A$
		$-40^\circ C \leq T_A \leq 85^\circ C$ , $V_{CM} = 4.7V$		1.5		
Input Offset Voltage	$V_{OS}$		-5	1	5	mV
Input Offset Average Drift	$\Delta V_{OS}/\Delta T$			2.7		$\mu V/^\circ C$
Common Mode Rejection Ratio	CMRR	$V_{CM}$ Stepped from 0V to 3.9V		85		dB
		$V_{CM}$ Stepped from 4.4V to 5V		89		
		$V_{CM}$ Stepped from 0V to 5V		85		
Power Supply Rejection Ratio	PSRR	$V_+ = 2.5V$ to 5.5V, $V_{CM} = (-V_+) + 0.5V$		70		dB
Latch Enable Pin High Input Voltage	$V_{IH}$			2.52		V
Latch Enable Pin Low Input Voltage	$V_{IL}$			1.97		V
Latch Enable Pin Bias Current	$I_{IL}$	$V_{LE} = 0V$		26.5		nA
Output Swing High	$V_{OH}$	$I_O = 500\mu A$		4.95		V
		$I_O = 1mA$		4.90		
Output Swing Low	$V_{OL}$	$I_O = -500\mu A$		30		mV
		$I_O = -1mA$		60		
Output Current	$I_{OUT}$	Source		25		mA
		Sink		25		
Propagation Delay (High to Low)		Overdrive = 10mV		3.50		$\mu s$
		Overdrive = 100mV		0.95		
Propagation Delay (Low to High)		Overdrive = 10mV		2.85		$\mu s$
		Overdrive = 100mV		1.10		
Rise Time	$t_{Rise}$	Overdrive = 10mV, $C_L = 30pF$ , $R_L = 1M\Omega$		75		ns
		Overdrive = 100mV, $C_L = 30pF$ , $R_L = 1M\Omega$		45		
Fall Time	$t_{Fall}$	Overdrive = 10mV, $C_L = 30pF$ , $R_L = 1M\Omega$		75		ns
		Overdrive = 100mV, $C_L = 30pF$ , $R_L = 1M\Omega$		45		

## CONTACT US

**D**ioo is a professional design and sales corporation for high-quality and performance analog semiconductors. The company focuses on industry markets, such as, cell phone, handheld products, laptop, and medical equipment and so on. Dioo's product families include analog signal processing and amplifying, LED drivers and charger IC. Go to <http://www.dioo.com> for a complete list of Dioo product families.

For additional product information, or full datasheet, please contact with our Sales Department or Representatives.

dioo

## X-ON Electronics

Largest Supplier of Electrical and Electronic Components

*Click to view similar products for [Analog Comparators](#) category:*

*Click to view products by [Dioo](#) manufacturer:*

Other Similar products are found below :

[633740E](#) [ADCMP396ARZ-RL7](#) [NCV2200SN2T1G](#) [NCV2200SQ2T2G](#) [SC339DR2G](#) [LM2901SNG](#) [LM339SNG](#) [AP393AM8G-13](#)  
[418524AB](#) [TS393CD C3](#) [LM393SNG](#) [55122](#) [5962-8757203IA](#) [MAX971ESA+T](#) [MAX961ESAT](#) [MAX944ESD+T](#) [MAX931ESAT](#)  
[MAX984CPE](#) [MAX9062EBSTG45](#) [MAX9041AEUTT](#) [MAX9022ASAT](#) [RT2902YDT](#) [M38510/11201B2A](#) [NTE911](#) [5962-8751601DA](#)  
[5962-8751601CA](#) [MAX961EUA+T](#) [MAX9065EBS+TG45](#) [NCV2202SN2T1G](#) [MAX919ESA+T](#) [LT6700HS6-2#TRMPBF](#) [MAX19005CCS+](#)  
[LM339EDR2G](#) [LT6700HS6-2#TRM](#) [NTE919](#) [NTE922](#) [TS883IQ2T](#) [LT6700HVCS6-3#TRMPBF](#) [LT6700HVHS6-3#TRMPBF](#)  
[MAX978EEE+T](#) [MAX975ESA+T](#) [MAX9602EUG+T](#) [MAX997EUA+T](#) [MIC841NYC5-T5](#) [LM393WDT](#) [MCP6564T-E/STVAO](#)  
[MAX983ESA+T](#) [NCX2200GMAZ](#) [LTC1540CMS8#PBF](#) [MC10E1651FNG](#)