

DIO2092

4.2mA, 10MHz, RRIO CMOS Operational Amplifier

Features

- Rail-to-Rail Output
- Low Noise: 11.27nV/√Hz
- Low Distortion
- Supply Voltage Range: 2.7V to 5.5V
- Low Input Offset Voltage: 3mV MAX
- Gain Bandwidth Product: 10MHz
- Slew Rate: 5.9V/μs
- Low Power: 4.2mA/Amplifier
- Over-heat Protection: >140°C
- Small Packaging:
- Available in Green MSOP-8 and SOIC-8

Applications

- Data Acquisition
- Process Control
- Active Filters
- Test Equipment
- Mobile Phone
- Audio Processing
- Video Processing
- Headphone Amplifier
- Portable Equipment
- Broadband Communications
- to-D Driver/ D-to-a Driver

Descriptions

The DIO2092 is a dual, rail-to-rail output operational amplifier that is optimized and fully specified for 5V operation. High output current allows low load impedances to be driven.

The DIO2092 has a wide input common-mode voltage range and output voltage swing, running at single supply voltage from 2.7V to 5.5V.

The DIO2092 provides excellent overall performance. It exhibits low noise and distortion, low offset and high output current capability, making this device an excellent choice for high quality, low voltage or battery operated audio systems.

The DIO2092 is offered in Green MSOP-8 and SOIC-8 packages. It is specified over the extended -40°C to +125°C temperature range.

Typical Application

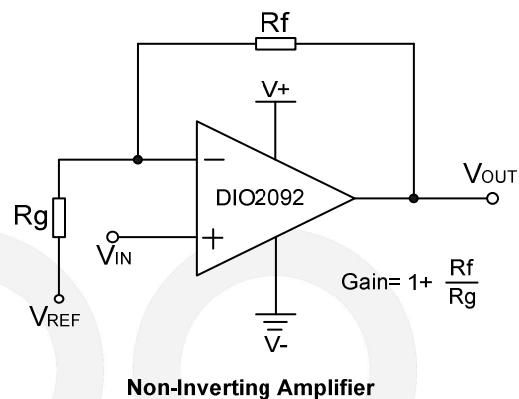

Ordering Information

Order Part Number	Top Marking		T _A	Package	
DIO2092SO8	DIO2092	Green or RoHS	-40 to +125°C	SOIC-8	Tape & Reel, 2500
DIO2092MP8	DIO2092	Green or RoHS	-40 to +125°C	MSOP-8	Tape & Reel, 3000

DIO2092

4.2mA, 10MHz, RRIO CMOS Operational Amplifier

Physical Dimensions: SOIC-8

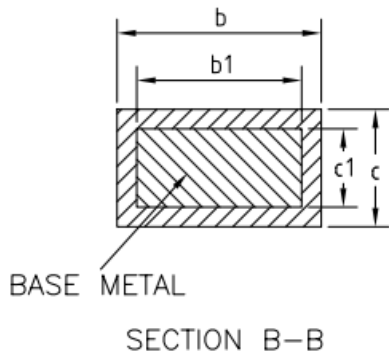
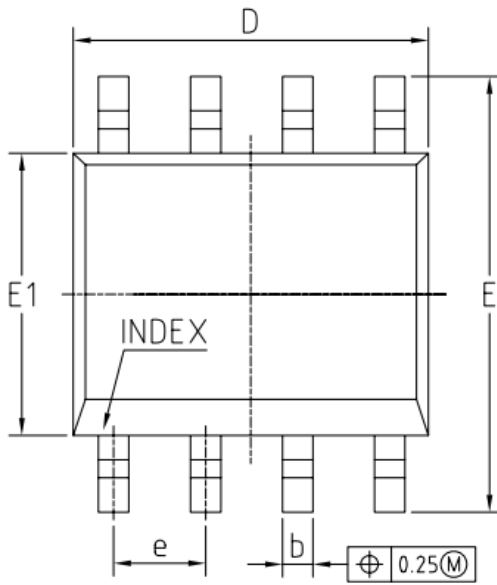
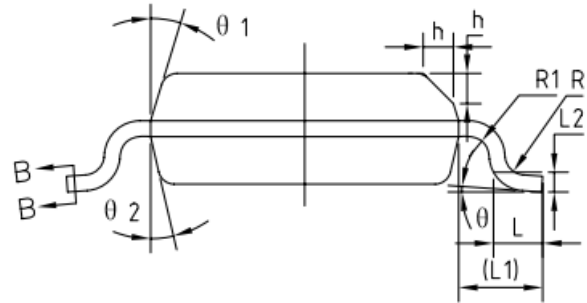
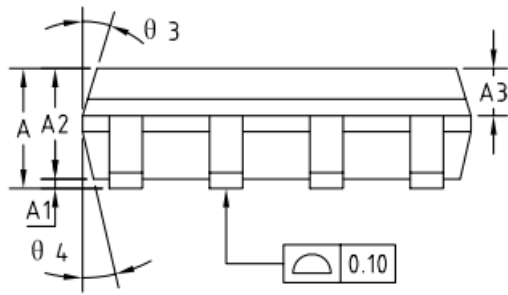

COMMON DIMENSIONS (UNITS OF MEASURE=MILLIMETER)			
Symbol	MIN	NOM	MAX
A	1.35	1.55	1.75
A1	0.10	0.15	0.25
A2	1.25	1.40	1.65
A3	0.50	0.60	0.70
b	0.38	-	0.51
b1	0.37	0.42	0.47
c	0.17	-	0.25
c1	0.17	0.20	0.23
D	4.80	4.90	5.00
E	5.80	6.00	6.20
E1	3.80	3.90	4.00
e	1.27BSC		
L	0.45	0.60	0.80
L1	1.04REF		
L2	0.25BSC		
R	0.07	-	-
R1	0.07	-	-
h	0.30	0.40	0.50
θ	0°	-	8°
θ1	15°	17°	19°
θ2	11°	13°	15°
θ3	15°	17°	19°
θ4	11°	13°	15°

DIO2092

4.2mA, 10MHz, RRIO CMOS Operational Amplifier

Physical Dimensions: MSOP-8

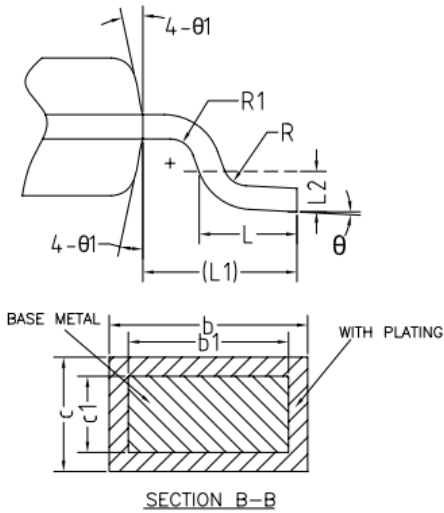
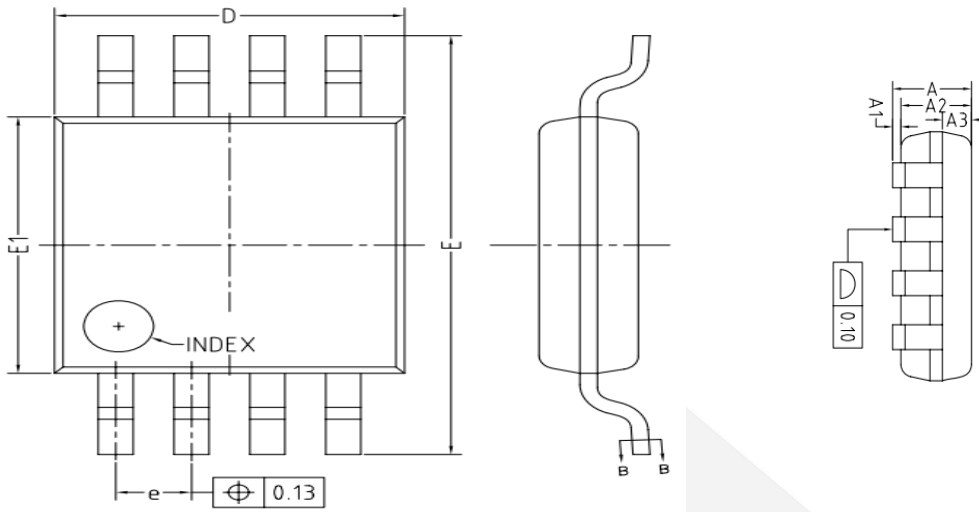

COMMON DIMENSIONS (UNITS OF MEASURE=MILLIMETER)			
Symbol	MIN	NOM	MAX
A	-	-	1.10
A1	0	-	0.15
A2	0.75	0.85	0.95
A3	0.25	0.35	0.39
b	0.28	-	0.37
b1	0.27	0.30	0.33
c	0.15	-	0.20
c1	0.14	0.15	0.16
D	2.90	3.00	3.10
E	4.70	4.90	5.10
E1	2.90	3.00	3.10
e	0.55	0.65	0.75
L	0.45	0.60	0.80
L1	0.95REF		
L2	0.25BSC		
R	0.07	-	-
R1	0.07	-	-
θ	0°	-	8°
θ1	9°	12°	15°

CONTACT US

Dioo is a professional design and sales corporation for high-quality and performance analog semiconductors. The company focuses on industry markets, such as, cell phone, handheld products, laptop, and medical equipments and so on. Dioo's product families include analog signal processing and amplifying, LED drivers and charger IC. Go to <http://www.dioo.com> for a complete list of Dioo product families.

For additional product information, or full datasheet, please contact with our Sales Department or Representatives.



X-ON Electronics

Largest Supplier of Electrical and Electronic Components

Click to view similar products for [Operational Amplifiers - Op Amps](#) category:

Click to view products by [Dioo](#) manufacturer:

Other Similar products are found below :

[NCV33072ADR2G](#) [LM358SNG](#) [430227FB](#) [UPC824G2-A](#) [LT1678IS8](#) [042225DB](#) [058184EB](#) [UPC822G2-A](#) [UPC259G2-A](#) [UPC258G2-A](#)
[NCV33202DMR2G](#) [NTE925](#) [AZV358MTR-G1](#) [AP4310AUMTR-AG1](#) [HA1630D02MMEL-E](#) [HA1630S01LPEL-E](#) [SCY33178DR2G](#)
[NJU77806F3-TE1](#) [NCV5652MUTWG](#) [NCV20034DR2G](#) [LM324EDR2G](#) [LM2902EDR2G](#) [NTE7155](#) [NTE778S](#) [NTE871](#) [NTE924](#) [NTE937](#)
[MCP6V17T-E/MNY](#) [MCP6V19-E/ST](#) [MXD8011HF](#) [MCP6V16UT-E/OT](#) [MCP6V17T-E/MS](#) [MCP6V19T-E/ST](#) [SCY6358ADR2G](#)
[ADA4523-1BCPZ](#) [ADA4523-1BCPZ-RL7](#) [2SD965T-R](#) [RS6332PXK](#) [BDM8551](#) [BDM321](#) [MD1324](#) [CA3140AN](#) [COS8052SR](#) [COS8552SR](#)
[COS8554SR](#) [COS2177SR](#) [COS2353SR](#) [COS724TR](#) [LM2902M/TR](#) [ASOPD4580S-R](#)