

DIO236X

Ultra Low Vos, Low Power Amplifier

Features

- Ultra low V_{OS} : DIO2361A/2A: 10 μ V(Max)
DIO2361B/2B: 20 μ V(Max)
DIO2361/2: 40 μ V(Max)
DIO2361M/2M: 65 μ V(Max)
- Low Power: 17.0 μ A(typ.)
- Unity Gain Stable
- Gain Bandwidth Product: 300kHz(typ.)
- Wide supply range: 1.8V to 5.5V
- Available in SOT23-5, SC70-5, SOIC-8, MSOP-8, DFN2*2-8 and DFN3*3-8 packages
- Temperature Range:
 - Industrial: -40°C to 85°C
 - Extended: -40°C to 125°C

Descriptions

DIO236x is a family of ultra low V_{OS} operational amplifier, with rail-to-rail CMOS input/output and single/dual channels selectable. DIO236x family has a gain-bandwidth product of 300kHz(typ.), wide operating supply voltage from 1.8V to 5.5V and broad output voltage swing.

DIO236x consumes ultra low power, with each channel 17.0 μ A(typ.) of bias current, which makes DIO236x be ideal for battery powered device, temperature-sense device, etc.

Typical Applications

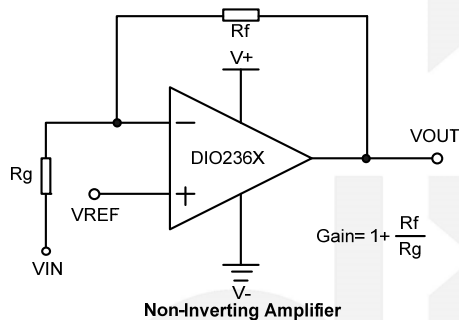

Applications

- Active Filters
- Data Acquisition
- Portable Equipment
- Test Equipment
- Broadband Communication
- Process Control
- Audio and Video Processing

Ordering Information

| Order Part Number | Top Marking | | T _A | Package | |
|-------------------|-------------|---------------|----------------|----------|-------------------|
| DIO2361ASC5 | W361 | Green or RoHS | -40 to 125°C | SC70-5 | Tape & Reel, 3000 |
| DIO2361AST5 | W361 | Green or RoHS | -40 to 125°C | SOT23-5 | Tape & Reel, 3000 |
| DIO2361ASO8 | DIO2361 | Green or RoHS | -40 to 125°C | SOIC-8 | Tape & Reel, 2500 |
| DIO2361AMP8 | DIO2361 | Green or RoHS | -40 to 125°C | MSOP-8 | Tape & Reel, 3000 |
| DIO2361BSC5 | W361 | Green or RoHS | -40 to 125°C | SC70-5 | Tape & Reel, 3000 |
| DIO2361BST5 | W361 | Green or RoHS | -40 to 125°C | SOT23-5 | Tape & Reel, 3000 |
| DIO2361BSO8 | DIO2361 | Green or RoHS | -40 to 125°C | SOIC-8 | Tape & Reel, 2500 |
| DIO2361BMP8 | DIO2361 | Green or RoHS | -40 to 125°C | MSOP-8 | Tape & Reel, 3000 |
| DIO2361SC5 | W361 | Green or RoHS | -40 to 125°C | SC70-5 | Tape & Reel, 3000 |
| DIO2361ST5 | W361 | Green or RoHS | -40 to 125°C | SOT23-5 | Tape & Reel, 3000 |
| DIO2361SO8 | DIO2361 | Green or RoHS | -40 to 125°C | SOIC-8 | Tape & Reel, 2500 |
| DIO2361MP8 | DIO2361 | Green or RoHS | -40 to 125°C | MSOP-8 | Tape & Reel, 3000 |
| DIO2361MSC5 | W361 | Green or RoHS | -40 to 125°C | SC70-5 | Tape & Reel, 3000 |
| DIO2361MST5 | W361 | Green or RoHS | -40 to 125°C | SOT23-5 | Tape & Reel, 3000 |
| DIO2361MSO8 | DIO2361 | Green or RoHS | -40 to 125°C | SOIC-8 | Tape & Reel, 2500 |
| DIO2361MMP8 | DIO2361 | Green or RoHS | -40 to 125°C | MSOP-8 | Tape & Reel, 3000 |
| DIO2362ACN8 | 2362 | Green or RoHS | -40 to 125°C | DFN2*2-8 | Tape & Reel, 3000 |
| DIO2362ACD8 | D2362 | Green or RoHS | -40 to 125°C | DFN3*3-8 | Tape & Reel, 5000 |
| DIO2362ASO8 | DIO2362 | Green or RoHS | -40 to 125°C | SOIC-8 | Tape & Reel, 2500 |
| DIO2362AMP8 | DIO2362 | Green or RoHS | -40 to 125°C | MSOP-8 | Tape & Reel, 3000 |
| DIO2362BCN8 | 2362 | Green or RoHS | -40 to 125°C | DFN2*2-8 | Tape & Reel, 3000 |
| DIO2362BCD8 | D2362 | Green or RoHS | -40 to 125°C | DFN3*3-8 | Tape & Reel, 5000 |
| DIO2362BSO8 | DIO2362 | Green or RoHS | -40 to 125°C | SOIC-8 | Tape & Reel, 2500 |
| DIO2362BMP8 | DIO2362 | Green or RoHS | -40 to 125°C | MSOP-8 | Tape & Reel, 3000 |
| DIO2362CN8 | 2362 | Green or RoHS | -40 to 125°C | DFN2*2-8 | Tape & Reel, 3000 |
| DIO2362CD8 | D2362 | Green or RoHS | -40 to 125°C | DFN3*3-8 | Tape & Reel, 5000 |
| DIO2362SO8 | DIO2362 | Green or RoHS | -40 to 125°C | SOIC-8 | Tape & Reel, 2500 |
| DIO2362MP8 | DIO2362 | Green or RoHS | -40 to 125°C | MSOP-8 | Tape & Reel, 3000 |
| DIO2362MCN8 | 2362 | Green or RoHS | -40 to 125°C | DFN2*2-8 | Tape & Reel, 3000 |
| DIO2362MCD8 | D2362 | Green or RoHS | -40 to 125°C | DFN3*3-8 | Tape & Reel, 5000 |
| DIO2362MSO8 | DIO2362 | Green or RoHS | -40 to 125°C | SOIC-8 | Tape & Reel, 2500 |
| DIO2362MMP8 | DIO2362 | Green or RoHS | -40 to 125°C | MSOP-8 | Tape & Reel, 3000 |

Ordering Information Complimentary Note

Ordering Code = Part No. + Package Code

DIO2361A/2A
DIO2361B/2B
DIO2361/2
DIO2361M/2M

SC5: stands for SC70-5
ST5: stands for SOT23-5
SO8: stands for SOIC-8
MP8: stands for MSOP-8
CN8: stands for DFN2*2-8
CD8: stands for DFN3*3-8

Pin Assignments

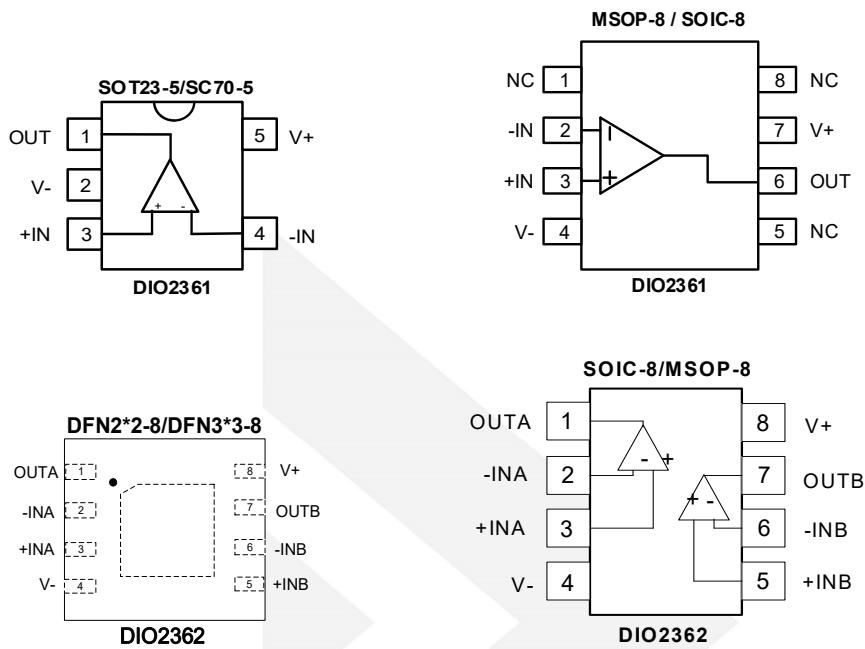

Figure 1 Top View

Pin Description

| Pin name | Description |
|----------|-----------------|
| V+ | Positive supply |
| V- | Negative supply |
| +INX | Positive Input |
| -INX | Negative Input |
| OUTX | Output |
| NC | No connect |

Absolute Maximum Ratings

Stresses beyond those listed under "Absolute Maximum Rating" may cause permanent damage to the device. These are stress ratings only and functional operation of the device at these or any other condition beyond those indicated in the operational sections of the specifications is not implied. Exposure to absolute maximum rating conditions for extended periods may affect device reliability.

| Parameter | | Rating | Unit |
|---------------------------|-------------------------|------------------------|------|
| Supply Voltage (V+ – V-) | | 7 | V |
| Input Voltage | | (V-)-0.3V to (V+) 0.3V | V |
| Difference Input Voltage | | V+ – V- | V |
| Storage Temperature Range | | -65 to 150 | °C |
| Junction Temperature | | 150 | °C |
| Lead Temperature Range | | 260 | °C |
| ESD | HBM, JEDEC: JESD22-A114 | 8 | kV |

Recommended Operating Conditions

The Recommended Operating Conditions table defines the conditions for actual device operation to ensure optimal performance to the datasheet specifications. DIOO does not recommend exceeding them or designing to Absolute Maximum Ratings.

| Parameter | | Rating | Unit |
|-----------------------------|--|------------|------|
| Supply Voltage | | 1.8 to 5.5 | V |
| Input Voltage | | 0 to 5 | V |
| Operating Temperature Range | | -40 to 125 | °C |



Electrical Characteristics

Typical value: $V_{CC}=5V$, $R_L=1M\Omega$ to $V_{CC}/2$, $V_{CM}=1/2V_{CC}$, $T_A = 25^\circ C$, unless otherwise specified.

| Symbol | Parameter | Conditions | Min. | Typ. | Max. | Unit | |
|-------------------------------|--------------------------------|---------------------------------------------------------|-------------|-------|--------------|------------------|---------|
| INPUT CHARACTERISTICS | | | | | | | |
| V_{OS} | Input Offset Voltage | $V_+=1.8V$ to $5.5V$ | DIO2361A/2A | -10 | | 10 | μV |
| | | | DIO2361B/2B | -20 | | 20 | |
| | | | DIO2361/2 | -40 | | 40 | |
| | | | DIO2361M/2M | -65 | | 65 | |
| I_B | Input Bias Current | $V_+=1.8V$ to $5.5V$ | | 1 | | pA | |
| I_{OS} | Input Offset Current | $V_+=1.8V$ to $5.5V$ | | 1 | | pA | |
| V_{CM} | Common Mode Voltage Range | | -0.1 | | (V+) +0.1 | V | |
| CMRR | Common Mode Rejection Ratio | $-40^\circ C \leq T_A \leq 125^\circ C$, | | 130 | | dB | |
| A_{OL} | Open Loop Voltage Gain | $R_L=50k\Omega$, $V_O=0.1$ to $(V_+)-0.1$ | 80 | 110 | | dB | |
| $\Delta V_{OS}/\Delta T$ | Input Offset Voltage Drift | $-40^\circ C \leq T_A \leq 125^\circ C$ | | 0.05 | | $\mu V/^\circ C$ | |
| OUTPUT CHARACTERISTICS | | | | | | | |
| V_{OH} | Output Voltage High | $R_L=50k\Omega$ $-40^\circ C \leq T_A \leq 125^\circ C$ | | 4.992 | | V | |
| V_{OL} | Output Voltage Low | $R_L=50k\Omega$ $-40^\circ C \leq T_A \leq 125^\circ C$ | | 8 | | mV | |
| I_{SC} | Output Short Circuit Current | Source I_{SC} , $V_+=5V$ | | 34 | | mA | |
| | | Sink I_{SC} , $V_+=5V$ | | 34 | | | |
| POWER SUPPLY | | | | | | | |
| PSRR | Power Supply Rejection Ration | | 100 | | | dB | |
| I_S | Supply Current per Channel/Amp | $-40^\circ C \leq T_A \leq 125^\circ C$ | | 17 | 27 | μA | |
| DYNAMIC PERFORMANCE | | | | | | | |
| GBP | Gain Bandwidth Product | $C_L=100pF$, $R_L=1M\Omega$ | | 300 | | kHz | |
| SR | Slew Rate | $G=1$, 2V Output Step | | 160 | | V/ms | |
| t_s | Setting Time | $G=1$, 2V Output Step | | 1 | | ms | |
| Θ_m | Phase Margin | | | 62 | | Deg | |
| t_r | Overload Recovery Time | | | 40 | | μs | |
| NOISE PERFORMANCE | | | | | | | |
| THD | Total Harmonic Distortion | $f=1kHz$, $4V_{PP}$, $R_L=5k\Omega$, | | 0.33 | | % | |

| | | | | | |
|-------|-----------------------|-----------------|--|----|------------------------------|
| e_n | Voltage Noise Density | $f=1\text{kHz}$ | | 70 | $\text{nV}/\sqrt{\text{Hz}}$ |
|-------|-----------------------|-----------------|--|----|------------------------------|

Specifications subject to change without notice.

Typical Performance Characteristics

I_s vs. V_{CC}

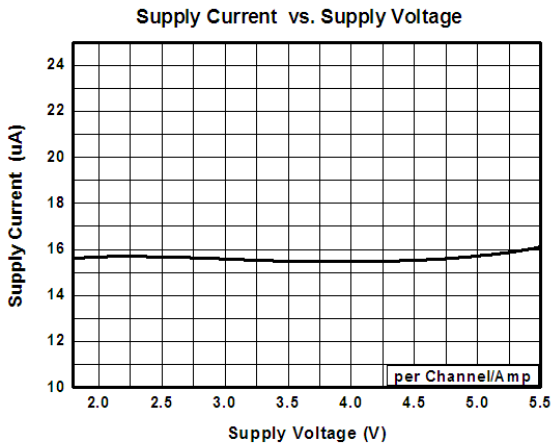

I_s vs. Temperature

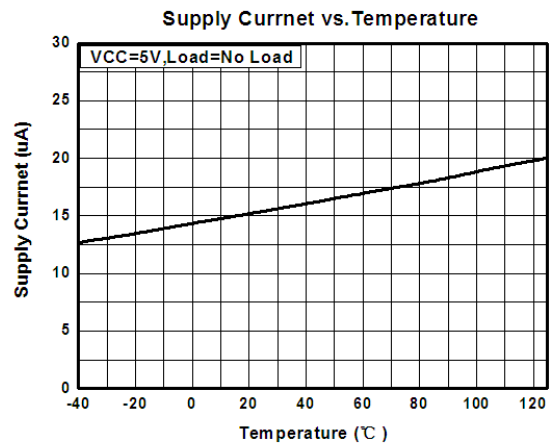

V_{os} vs. V_{CC}

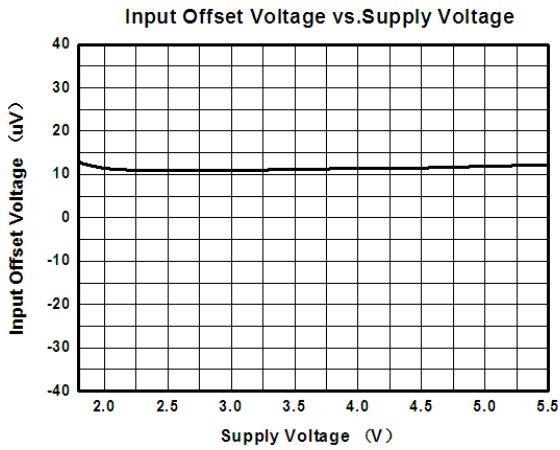

V_{os} vs. Temperature

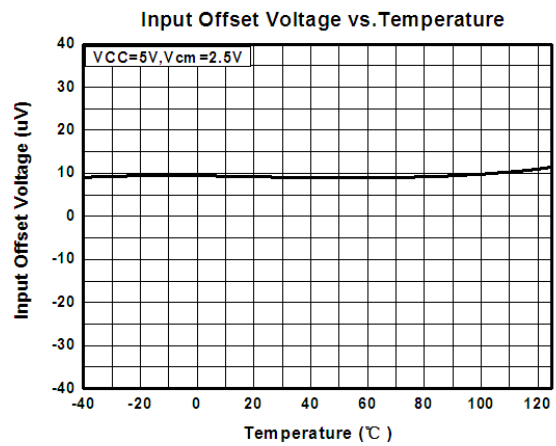

Typical Performance Characteristics (Continue)

Small-signal Response
($V_{CC}=5V$, $C_L=200pF$)

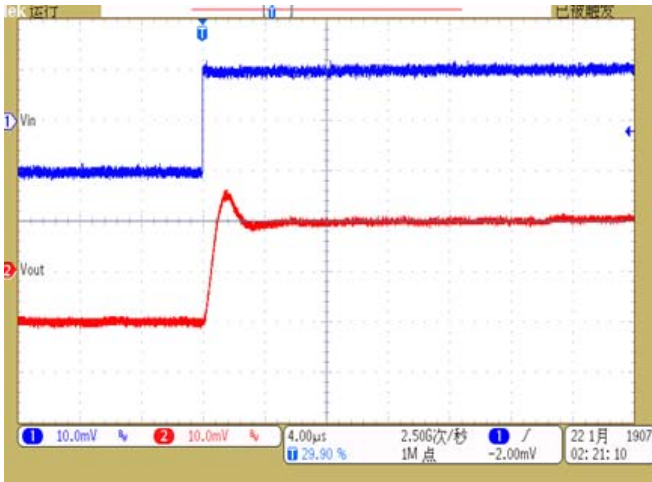

Small-signal Response
($V_{CC}=5V$, $C_L=200pF$)

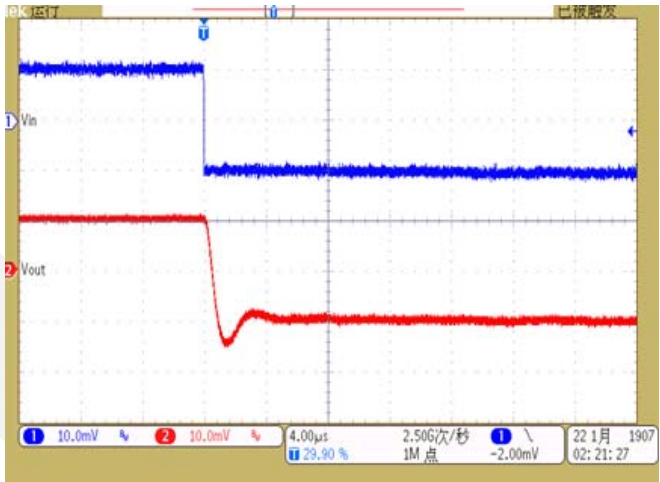

Large-signal Response
($V_{CC}=5V$, $R_L=5.1k\Omega$)

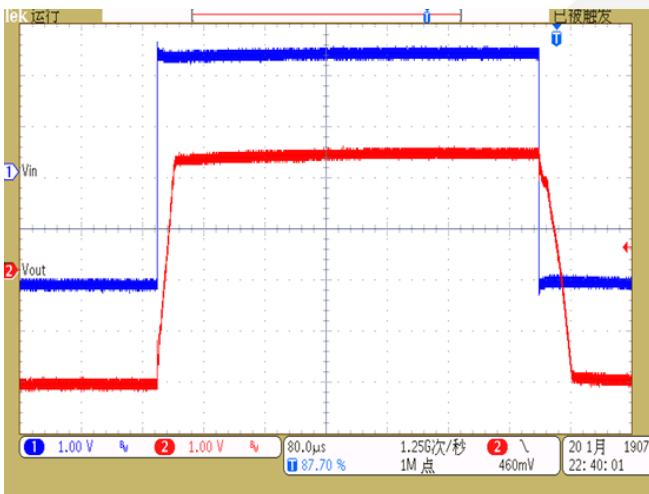

Physical Dimensions: SC70-5

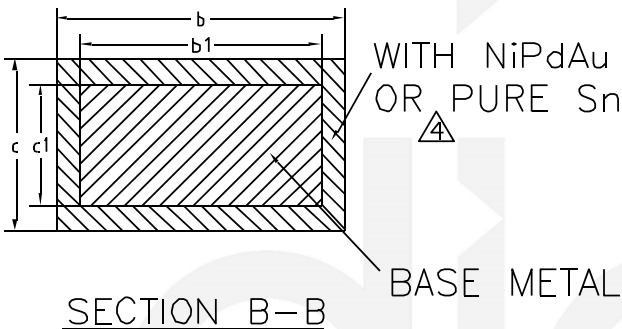
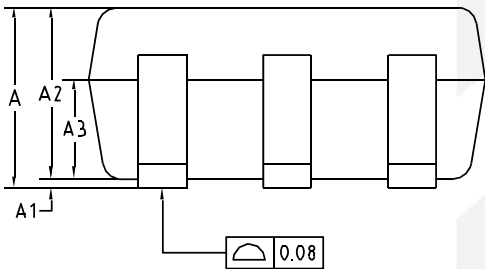
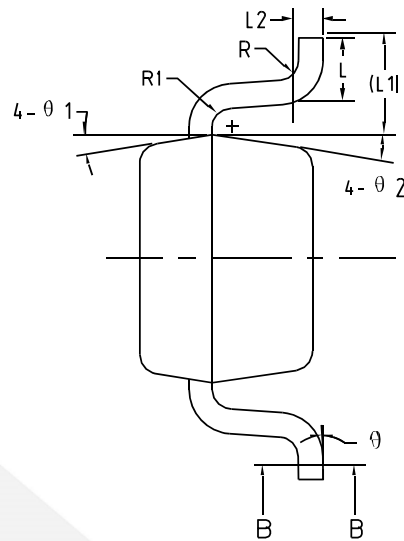
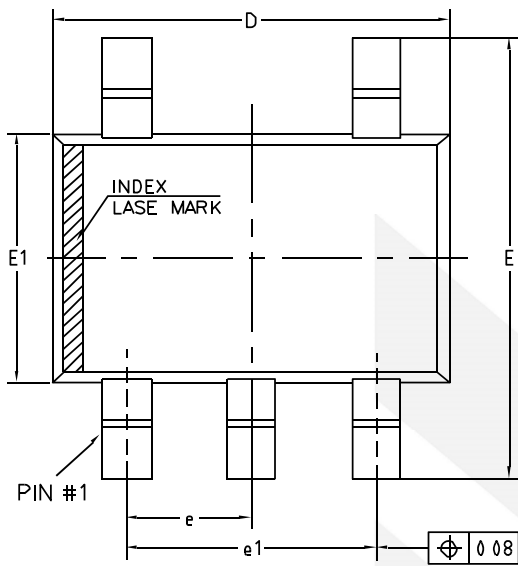

| COMMON DIMENSIONS (UNITS OF MEASURE=MILLIMETER) | | | |
|----------------------------------------------------|---------|------|------|
| Symbol | MIN | NOM | MAX |
| A | 0.85 | - | 1.05 |
| A1 | 0 | - | 0.10 |
| A2 | 0.80 | 0.90 | 1.00 |
| A3 | 0.47 | 0.52 | 0.57 |
| b | 0.23 | - | 0.33 |
| b1 | 0.22 | 0.25 | 0.28 |
| c | 0.12 | - | 0.18 |
| c1 | 0.115 | 0.13 | 0.14 |
| D | 2.02 | 2.07 | 2.12 |
| E | 2.20 | 2.30 | 2.40 |
| E1 | 1.25 | 1.30 | 1.35 |
| e | 0.65BSC | | |
| e1 | 1.30BSC | | |
| L | 0.28 | 0.33 | 0.38 |
| L1 | 0.50REF | | |
| L2 | 0.15BSC | | |
| R | 0.10 | - | - |
| R1 | 0.10 | - | 0.25 |
| θ | 0° | - | 8° |
| θ1 | 6° | 9° | 12° |
| θ2 | 6° | 9° | 12° |

Physical Dimensions: SOT23-5

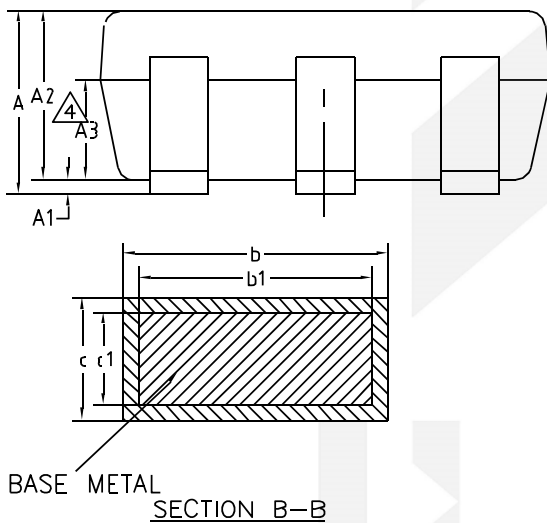
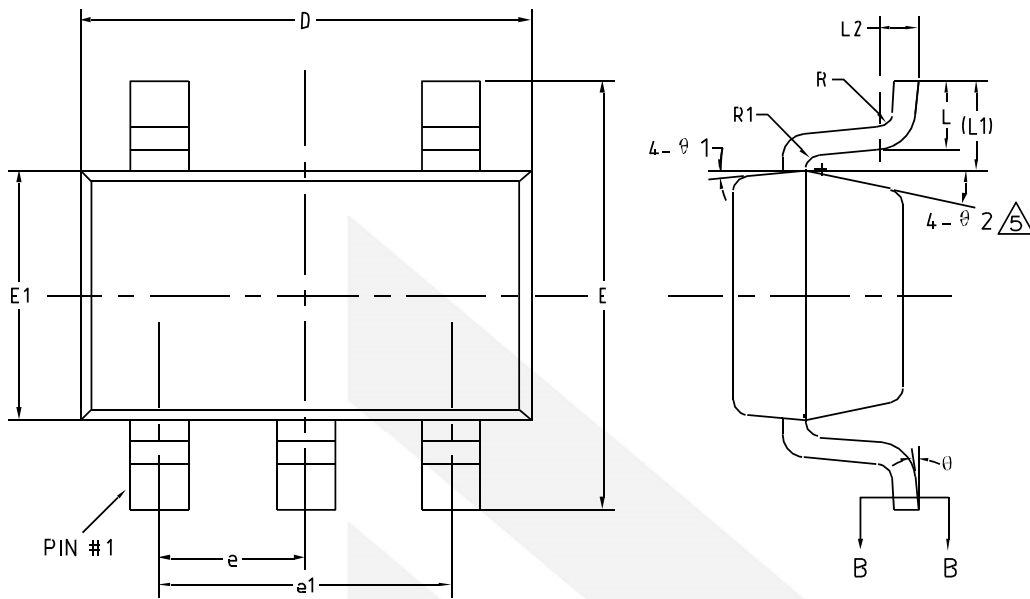

| COMMON DIMENSIONS (UNITS OF MEASURE=MILLIMETER) | | | |
|----------------------------------------------------|---------|-------|-------|
| Symbol | MIN | NOM | MAX |
| A | - | - | 1.25 |
| A1 | 0 | - | 0.15 |
| A2 | 1.00 | 1.10 | 1.20 |
| A3 | 0.60 | 0.65 | 0.70 |
| b | 0.36 | - | 0.50 |
| b1 | 0.36 | 0.38 | 0.45 |
| c | 0.14 | - | 0.20 |
| c1 | 0.14 | 0.15 | 0.16 |
| D | 2.826 | 2.926 | 3.026 |
| E | 2.60 | 2.80 | 3.00 |
| E1 | 1.526 | 1.626 | 1.726 |
| e | 0.90 | 0.95 | 1.00 |
| e1 | 1.80 | 1.90 | 2.00 |
| L | 0.35 | 0.45 | 0.60 |
| L1 | 0.59REF | | |
| L2 | 0.25BSC | | |
| R | 0.10 | - | - |
| R1 | 0.10 | - | 0.25 |
| θ | 0° | - | 8° |
| θ1 | 3° | 5° | 7° |
| θ2 | 6° | - | 14° |

Physical Dimensions: DFN2*2-8

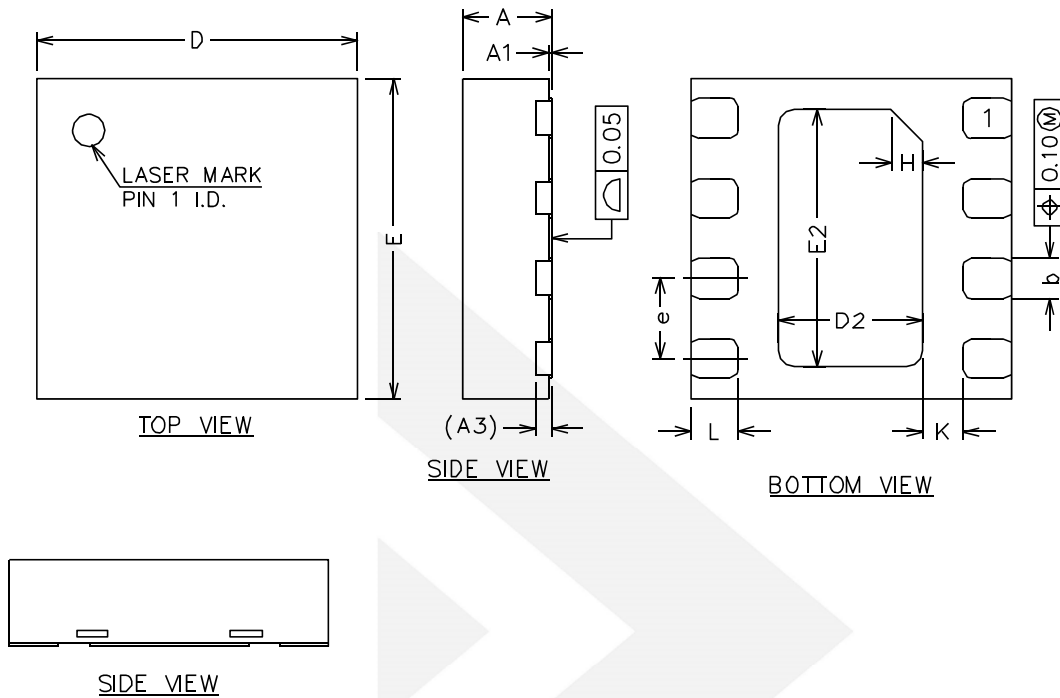

| COMMON DIMENSIONS (UNITS OF MEASURE=MILLIMETER) | | | |
|----------------------------------------------------|---------|------|------|
| Symbol | MIN | NOM | MAX |
| A | 0.50 | 0.55 | 0.65 |
| A1 | 0.00 | 0.02 | 0.05 |
| A3 | 0.10REF | | |
| b | 0.20 | 0.25 | 0.30 |
| D | 1.90 | 2.00 | 2.10 |
| E | 1.90 | 2.00 | 2.10 |
| D2 | 0.80 | 0.90 | 1.00 |
| E2 | 1.50 | 1.60 | 1.70 |
| e | 0.40 | 0.50 | 0.60 |
| H | 0.20REF | | |
| K | 0.15 | 0.25 | 0.35 |
| L | 0.25 | 0.30 | 0.35 |

Physical Dimensions: DFN3*3-8

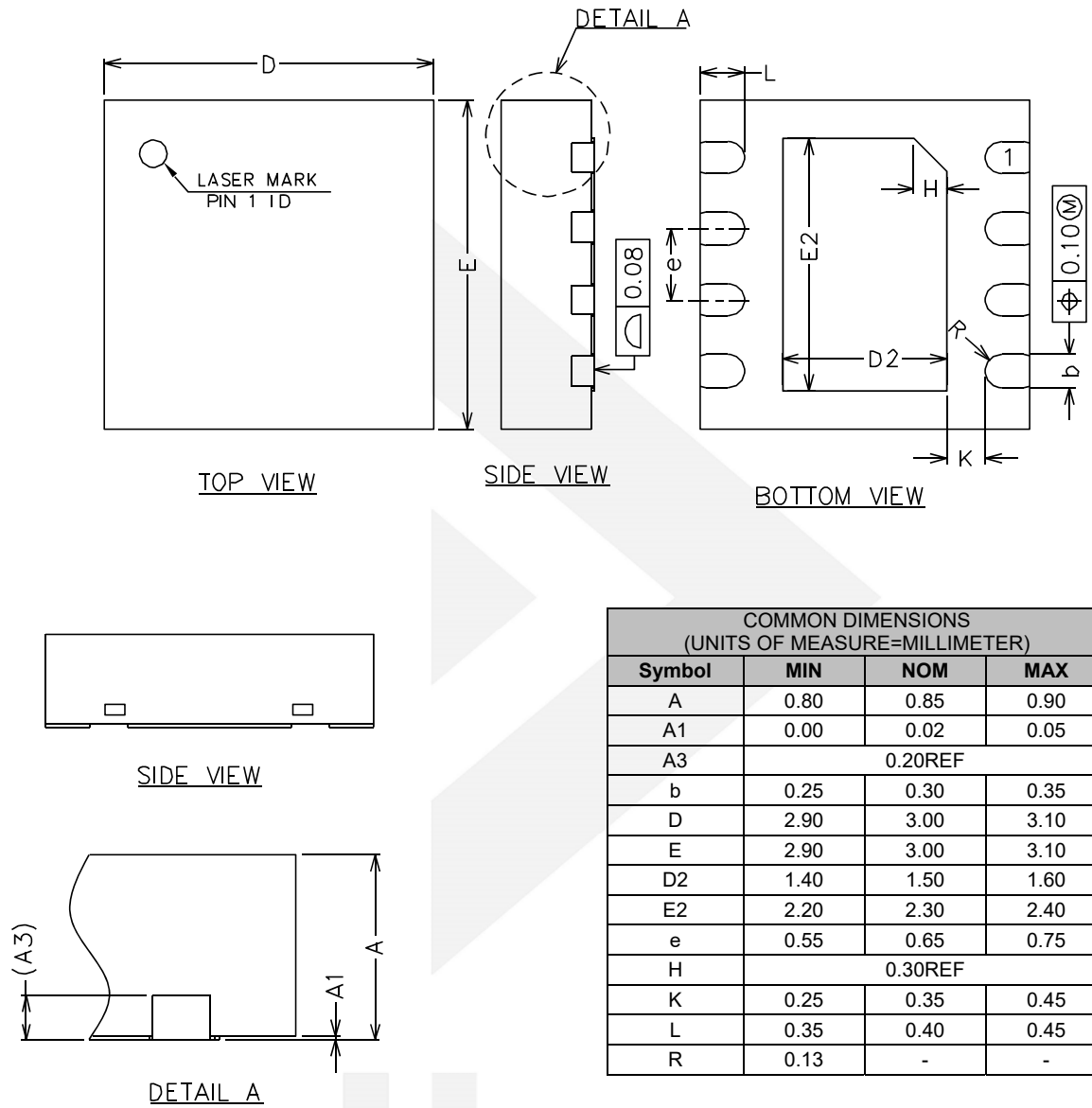

Physical Dimensions: SOIC-8

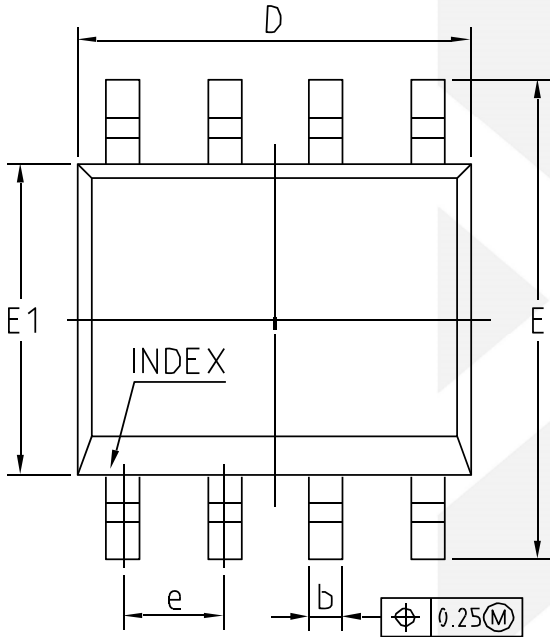
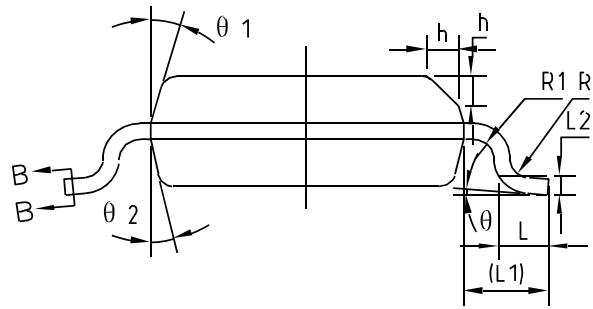
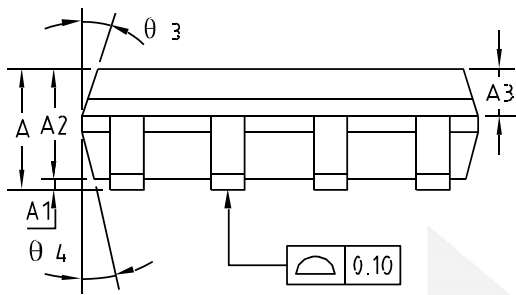

| COMMON DIMENSIONS (UNITS OF MEASURE=MILLIMETER) | | | |
|----------------------------------------------------|---------|------|------|
| Symbol | MIN | NOM | MAX |
| A | 1.35 | 1.55 | 1.75 |
| A1 | 0.10 | 0.15 | 0.25 |
| A2 | 1.25 | 1.40 | 1.65 |
| A3 | 0.50 | 0.60 | 0.70 |
| b | 0.38 | - | 0.51 |
| b1 | 0.37 | 0.42 | 0.47 |
| c | 0.17 | - | 0.25 |
| c1 | 0.17 | 0.20 | 0.23 |
| D | 4.80 | 4.90 | 5.00 |
| E | 5.80 | 6.00 | 6.20 |
| E1 | 3.80 | 3.90 | 4.00 |
| e | 1.27BSC | | |
| L | 0.45 | 0.60 | 0.80 |
| L1 | 1.04REF | | |
| L2 | 0.25BSC | | |
| R | 0.07 | - | - |
| R1 | 0.07 | - | - |
| h | 0.30 | 0.40 | 0.50 |
| θ | 0° | - | 8° |
| θ1 | 15° | 17° | 19° |
| θ2 | 11° | 13° | 15° |
| θ3 | 15° | 17° | 19° |
| θ4 | 11° | 13° | 15° |

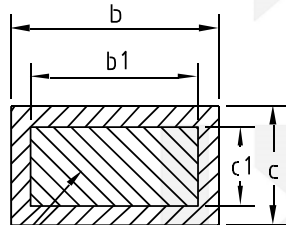

BASE METAL

SECTION B-B

Physical Dimensions: MSOP-8

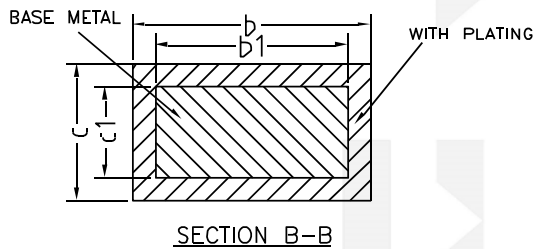
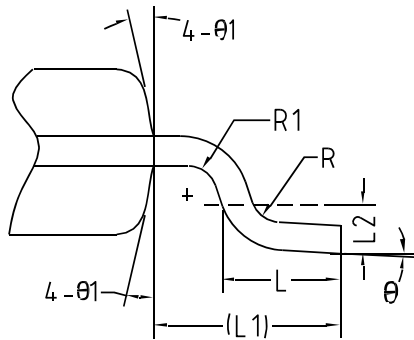
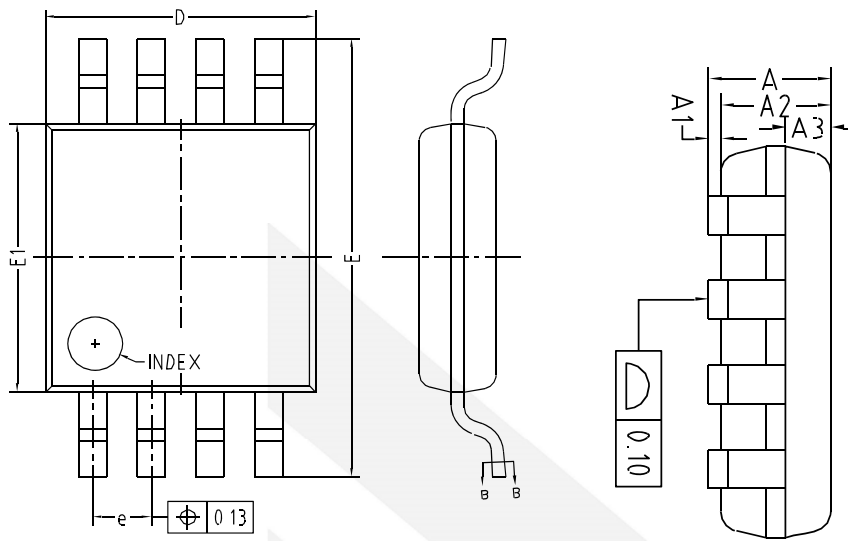

| COMMON DIMENSIONS (UNITS OF MEASURE=MILLIMETER) | | | |
|----------------------------------------------------|---------|------|------|
| Symbol | MIN | NOM | MAX |
| A | - | - | 1.10 |
| A1 | 0 | - | 0.15 |
| A2 | 0.75 | 0.85 | 0.95 |
| A3 | 0.25 | 0.35 | 0.39 |
| b | 0.28 | - | 0.37 |
| b1 | 0.27 | 0.30 | 0.33 |
| c | 0.15 | - | 0.20 |
| c1 | 0.14 | 0.15 | 0.16 |
| D | 2.90 | 3.00 | 3.10 |
| E | 4.70 | 4.90 | 5.10 |
| E1 | 2.90 | 3.00 | 3.10 |
| e | 0.55 | 0.65 | 0.75 |
| L | 0.40 | 0.60 | 0.80 |
| L1 | 0.95REF | | |
| L2 | 0.25BSC | | |
| R | 0.07 | - | - |
| R1 | 0.07 | - | - |
| θ | 0° | - | 8° |
| θ1 | 9° | 12° | 15° |

CONTACT US

Dioo is a professional design and sales corporation for high-quality and performance analog semiconductors. The company focuses on industry markets, such as, cell phone, handheld products, laptop, and medical equipment and so on. Dioo's product families include analog signal processing and amplifying, LED drivers and charger IC. Go to <http://www.dioo.com> for a complete list of Dioo product families.

For additional product information, or full datasheet, please contact with our Sales Department or Representatives.

A large, light gray watermark of the Dioo logo is centered on the page. It consists of a stylized arrow pointing right above the word "dioo" in a lowercase, sans-serif font.

X-ON Electronics

Largest Supplier of Electrical and Electronic Components

Click to view similar products for [Operational Amplifiers - Op Amps](#) category:

Click to view products by [Dioo](#) manufacturer:

Other Similar products are found below :

[OPA2991IDSGR](#) [OPA607IDCKT](#) [007614D](#) [633773R](#) [635798C](#) [635801A](#) [702115D](#) [709228FB](#) [741528D](#) [NCV33072ADR2G](#)
[SC2902DTBR2G](#) [SC2903DR2G](#) [SC2903VDR2G](#) [LM258AYDT](#) [LM358SNG](#) [430227FB](#) [430228DB](#) [460932C](#) [AZV831KTR-G1](#) [409256CB](#)
[430232AB](#) [LM2904DR2GH](#) [LM358YDT](#) [LT1678IS8](#) [042225DB](#) [058184EB](#) [070530X](#) [SC224DR2G](#) [SC239DR2G](#) [SC2902DG](#)
[SCYA5230DR2G](#) [714228XB](#) [714846BB](#) [873836HB](#) [MIC918YC5-TR](#) [TS912BIYDT](#) [NCS2004MUTAG](#) [NCV33202DMR2G](#)
[M38510/13101BPA](#) [NTE925](#) [SC2904DR2G](#) [SC358DR2G](#) [LM358EDR2G](#) [AZV358MTR-G1](#) [AP4310AUMTR-AG1](#) [HA1630D02MMEL-E](#)
[NJM358CG-TE2](#) [HA1630S01LPEL-E](#) [LM324AWPT](#) [HA1630Q06TELL-E](#)