

DIO2511

2-Vrms Audio Line Driver with Integrated One-ch, 6th-Order SD Video Filter

Features

- Line Output:able to drive 600ohm and 10kΩ
 - 2-Vrms With 3.3V Supply Voltage
 - No Pop/Clicks Noise at the line output when Power ON/OFF
 - No Need for Output DC-Blocking Capacitors
 - Accepting Differential Input
- SD Filter: One-ch 6th-order 11MHz SD filters
 - 6dB Output Driver Gain
 - Drive Dual Video Load
 - Transparent Input Clamping
 - AC or DC Coupled Inputs/Outputs
- Optimized Frequency Response between 20Hz–20kHz

Applications

- DVD Players
- Video Amplifiers
- Set-Top Boxes
- Personal Video Recorders
- Communications Devices

Descriptions

The DIO2511 is an integrated solution for Video driver and Audio driver, with two separated modules, the Audio Line Driver module and One-ch 6th-order SD Video filter driver module.

The Audio Line Driver allow for the removal of output AC-coupling capacitors. It is designed to optimize the audio driver circuit performance while reducing the BOM cost by eliminating the peripheral discrete components for noise reduction. Featuring differential input mode, gain range of $\pm 1V/V$ to $\pm 10V/V$ can be achieved via external gain resistor setting.

The 6th-order SD Video filter driver provides improved image quality compared with passive LC filters and discrete driver solution, especially suited for standard definition video signals. It can be directly driven by a DC-coupled DAC output or an AC-coupled signal. Internal diode-like clamps and bias circuitry may be used if AC-coupled inputs are required. The output can also drive AC or DC coupled single (150Ω) or dual (75Ω) loads. The DC coupling capacitors can be removed.

Ordering Information

Order Part Number	Top Marking		T _A	Package	
DIO2511CS16	DIO2511	Green/RoHS	-40 to +85°C	SOIC-16	Tape & Reel, 2500
DIO2511CT16	DIO2511	Green/RoHS	-40 to +85°C	TSSOP-16	Tape & Reel, 2500

Pin Assignments

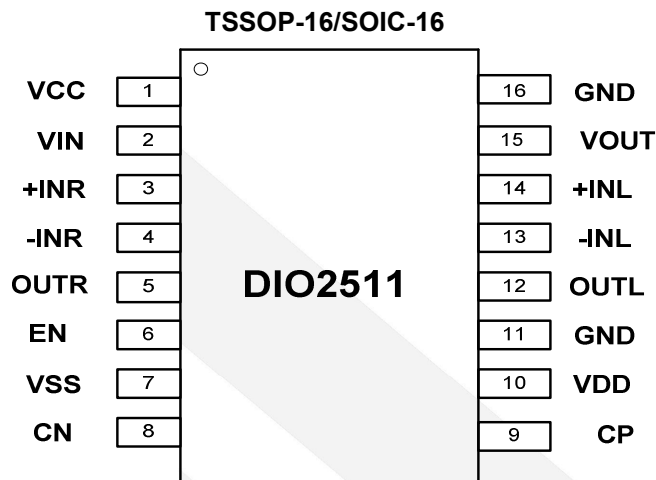

Figure 1 Pin Assignment

Pin Description

Pin Name	Description
VCC	Video filter driver power supply
VIN	Video filter driver Input
+INR	Right channel Positive Input
-INR	Right channel Negative Input
OUTR	Right channel Output
EN	Mute input, active-low
VSS	Supply voltage output
CN	Charge-pump flying capacitor negative terminal
CP	Charge-pump flying capacitor positive terminal
VDD	Audio line driver positive supply
GND	GND
OUTL	Left channel Output
-INL	Left channel Negative Input
+INL	Left channel Positive Input
VOUT	Video filter driver Output



DIO2511

2-Vrms Audio Line Driver with Integrated 6th-Order SDVideo Filter

Block Diagram

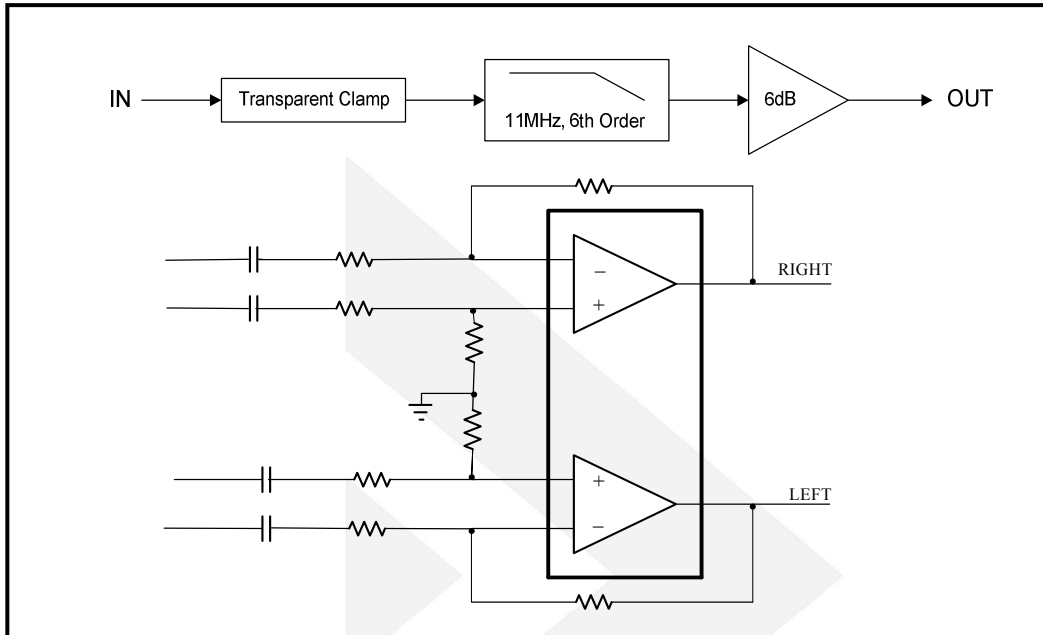

Absolute Maximum Ratings

Stresses beyond those listed under “Absolute Maximum Rating” may cause permanent damage to the device. These are stress ratings only and functional operation of the device at these or any other condition beyond those indicated in the operational sections of the specifications is not implied. Exposure to absolute maximum rating conditions for extended periods may affect device reliability.

Parameter	Rating	Unit
Supply Voltage/VCC	0 to 6.0	V
Supply Voltage/VDD	-0.3 to 4	V
Input Voltage/VIN	-0.3 to V _{CC} +0.3	V
Input Voltage/-INR, -INL	V _{SS} -0.3 to V _{DD} +0.3	V
Minimum load impedance	600	Ω
EN to GND	-0.3 to V _{DD} +0.3	V
Storage Temperature Range	-65 to 150	°C
Junction Temperature	150	°C
Lead Temperature Range	260	°C
HBM ESD JEDEC: JESD22-A114	Output Pins	8
	All Pins	5
		kV



DIO2511

2-Vrms Audio Line Driver with Integrated 6th-Order SDVideo Filter

Recommended Operating Conditions

The Recommended Operating Conditions table defines the conditions for actual device operation to ensure optimal performance to the datasheet specifications. DIOO does not recommend exceeding them or designing to Absolute Maximum Ratings.

Symbol	Parameter	Min.	Typ.	Max.	Unit
VDD	Supply Voltage	3	3.3	3.6	V
VCC	Supply Voltage	3.135		5.5	V
V _{IH}	EN High level Input Voltage		60		% of V _{DD}
V _{IL}	EN Low level Input Voltage		40		% of V _{DD}
T _A	Operating Temperature Range	-40		85	°C

Notes: The items below were divided into two parts, the Audio Line driver module and the SD Video filter module.

Electrical Characteristics for the Audio Line Driver module

Typical value: T_A = 25°C, V_{DD}=3.3V, unless otherwise specified.

Symbol	Parameter	Conditions	Min.	Typ.	Max.	Unit
V _{OS}	Output Offset Voltage	V _{DD} =3.3V, Input grounded, Unity gain		0.9		mV
PSRR	Power supply rejection ratio	V _{DD} =3.3V		90		dB
V _{OH}	High level output voltage	V _{DD} =3.3V, R _L =10kΩ	3.1			V
V _{OL}	Low level output voltage	V _{DD} =3.3V, R _L =10kΩ			-3.05	V
I _{IH}	EN High level input current	V _{DD} =3.3V, V _I =V _{DD}			1	μA
I _{IL}	EN Low level input current	V _{DD} =3.3V, V _I =0V			1	μA
I _{DD}	Supply current	V _{DD} =3.3V, V _I = V _{DD} , No load		14		mA
		Mute mode, V _{DD} =3.3V		0.8		
V _O	Output Voltage	THD=1%, V _{DD} =3.3V, f=1kHz	2.0	2.3		V _{RMS}
THD+N	Total harmonic distortion + noise	V _O =2V _{RMS} , f=1kHz		0.0005		%
X _{TALK}	Channel crosstalk	V _O =2V _{RMS} , f=1kHz		-105		dB
SNR	Signal noise ratio	V _O =2V _{RMS} , BW=22kHz, A-weighted	95	105		dB
C _L	Maximum capacitive load			220		pF
V _N	Noise output voltage	BW=20Hz to 22kHz		10		μV _{RMS}
G _{BW}	Unity gain bandwidth			6.5		MHz
A _{VO}	Open loop voltage gain			165		dB
f _{CP}	Charge pump frequency			300		kHz



DIO2511

2-Vrms Audio Line Driver with Integrated 6th-Order SDVideo Filter

Electrical Characteristics for the SD Video Filter module

Typical value: $T_A = 25^\circ\text{C}$, $V_{CC}=5\text{V}$, $R_{SOURCE}=37.5\Omega$, $R_L=150\Omega$ loads; all inputs are AC couple with $0.1\mu\text{F}$; all outputs are AC coupled with $220\mu\text{F}$; unless otherwise specified.

Symbol	Parameter	Conditions	Min.	Typ.	Max.	Unit
DC ELECTRICAL CHARACTERISTICS						
I_{CC}	Supply Current			8	12	mA
V_{IN}	Video Input Voltage Range		GND	1.4		V_{PP}
PSRR	Power Supply Rejection			-50		dB
DYNAMIC PERFORMANCE						
AV	Channel Gain		5.8	6.0	6.2	dB
f_{1dB}	-1dB Bandwidth		8.0	10.5		MHz
f_{3dB}	-3dB Bandwidth		9	11.8		MHz
	Filter Response	$f=27\text{MHz}$		-40		dB
DG	Differential Gain			0.2		%
DP	Differential Phase			0.36		$^\circ$
THD	Output Distortion	$f=1\text{MHz}$		0.38		%
X_{TALK}	Crosstalk	$f=1\text{MHz}$		-74		dB
SNR	Signal to Noise Ratio			70		dB
	Group Delay	$f=400\text{kHz}, 6.5\text{MHz}$		20		ns
CLG_SD	Chroma Luma Gain	$f=3.58\text{MHz}$ ref to SD in at 400kHz	95	100	105	%
CLD_SD	Chroma Luma Delay	$f=3.58\text{MHz}$ ref to SD in at 400kHz		5.5		ns

Notes: $SNR=20 \cdot \log(714\text{mV} / \text{rms noise})$.

Specifications subject to change without notice.



DIO2511

Typical Application

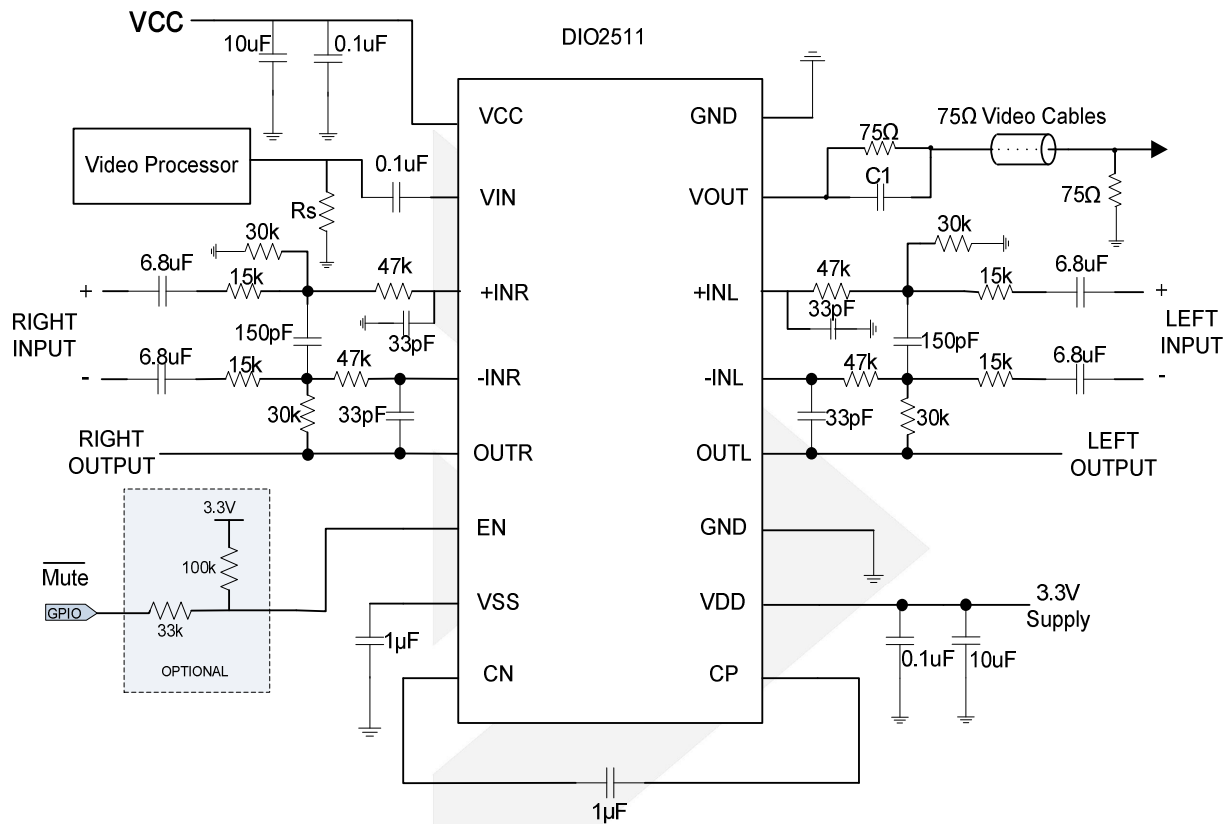

Note: The value of C1 is recommended 2 to 4pF.

Important Note:

In some applications, if the power supply noise needs to be filtered, the ferrite bead is recommended in a value of 600ohm@100MHz, instead of RC network. RC network normally will lower the power supply resulting in the degraded the audio performance. If the resistor is not chosen properly, which can trigger the internal UVP detection circuit and mute the output. As depicted below.



Application Notes

Gain-Setting Resistors Ranges and Input-Blocking Capacitors

The gain-setting resistors, R_{IN} and R_{FB} , must be chosen so that noise, stability, and input capacitor size of the Audio Line Driver are kept within acceptable limits. Voltage gain is defined as R_{FB} divided by R_{IN} .

Table 1 lists the recommended resistor value for different gain settings. Selecting values that are too low demands a large input ac-coupling capacitor C_{IN} . Selecting values that are too high increases the noise of the amplifier.

The gain-setting resistor must be placed close to the input pins to minimize capacitive loading on these input pins and to ensure maximum stability.

Table 1 Resistor Values Recommended

Input Res./ R_{IN}	Feedback Res./ R_{fb}	Differential Gain	Inverting Gain	Non-inverting Gain
22 k Ω	22 k Ω	1 V/V	-1 V/V	2 V/V
15 k Ω	30 k Ω	2 V/V	-2 V/V	3 V/V
10 k Ω	100 k Ω	10 V/V	-10 V/V	11 V/V

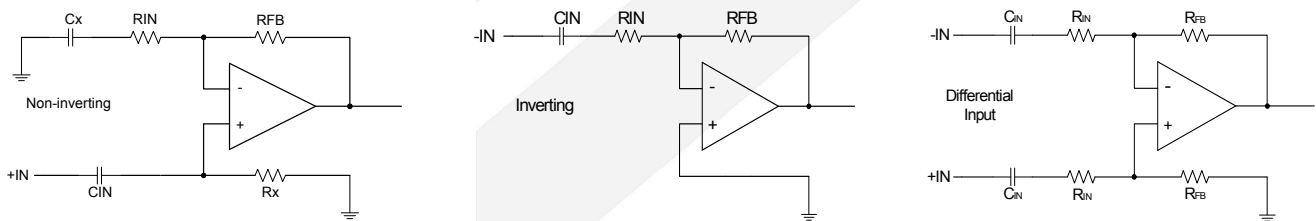

Figure 2 Differential, Inverting and Non-inverting Gain Configurations

DC input-blocking capacitors are required to be added in series with the audio signal into the input pins of the Audio Line Driver. These capacitors block the dc portion of the audio source and allow the Audio Line Driver inputs to be properly biased to provide maximum performance.

2nd Order Filter Typical Application

Several audio DACs used today require an external low-pass filter to remove out-of-band noise. This is possible with the Audio Line Driver, as it can be used like a standard OPAMP. Several filter topologies can be implemented, both single-ended and differential. In Figure 3, a multi-feedback (MFB) with differential input and single-ended input is shown.

An Ac-coupling capacitor to remove dc content from the source is shown; it serves to block any dc content from the source and lowers the dc-gain to 1, helping reducing the output dc-offset to minimum. The resistor values should have a low value for obtaining low noise, but should also have a high enough value to get a small size ac-coupling capacitor

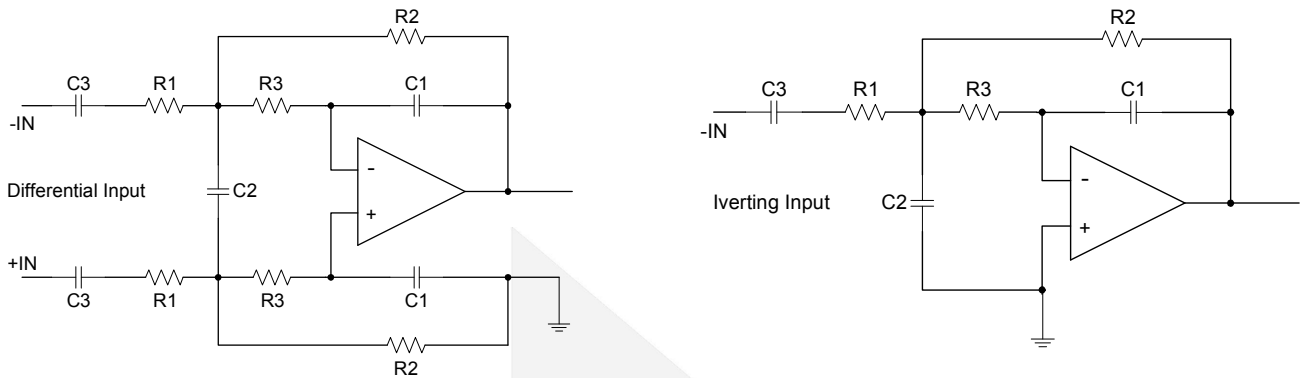

Figure 3 Second-Order Active Low-Pass Filter

Charge Pump Flying Capacitor and VSS Capacitor

The charge pump flying capacitor serves to transfer charge during the generation of the negative supply voltage. The VSS capacitor must be at least equal to the charge pump capacitor in order to allow maximum charge transfer. Low-ESR capacitors are an ideal selection, and a value of 1 μ F is typical. Capacitor values that are smaller than 1 μ F can be used, but the maximum output voltage may be reduced and the device may not operate to specifications

Decoupling Capacitors

The Audio Line Driver requires adequate power supply decoupling to ensure that the noise and total harmonic distortion (THD) are low. A good low equivalent-series-resistance (ESR) ceramic capacitor, typically 1 μ F, placed as close as possible to the device VDD lead works best. Placing this decoupling capacitor close to the Audio Line Driver is important for the performance of the amplifier. For filtering lower-frequency noise signals, a 10 μ F or greater capacitor placed near the audio power amplifier would also help, but it is not required in most applications because of the high PSRR of this device.

Pop-Free Power-Up

Pop-free power up is ensured by keeping the Mute (shutdown pin) low during power-supply ramp up and ramp down. The Mute pin should be kept low until the input ac-coupling capacitors are fully charged before asserting the Mute pin high to achieve pop-less power up. Figure 4 illustrates the preferred sequence.

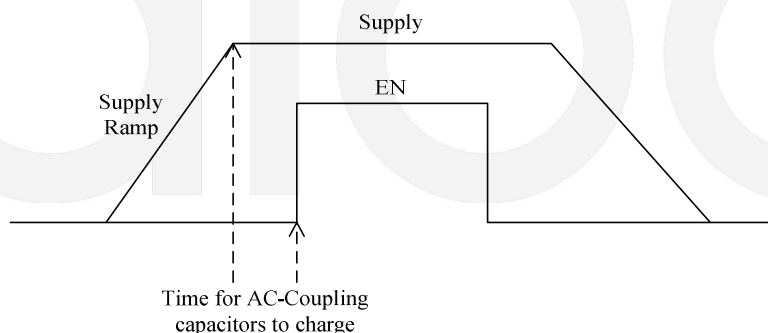

Figure 4 Power-Up Sequences



DIO2511

Internal Under-Voltage Protection(UVP) Detection

When VDD is higher than 2.95V (typical), the product will be powered ON. While VDD drops below 2.85V (typical), the internal power supply detection circuit will turn on the mute circuits, eliminates the pop noise of power down by shunting all necessary charge to the ground. Usually there is no need of external power ON/OFF detection to further reduce the system BOM cost.

Capacitive Load

The Audio Line Driver has the ability to drive a high capacitive load up to 220 pF directly. Higher capacitive loads can be accepted by adding a series resistor of 47 Ω or larger.

2-Vrms Audio Line Driver with Integrated 6th-Order SDVideo Filter





DIO2511

2-Vrms Audio Line Driver with Integrated 6th-Order SDVideo Filter

Physical Dimensions: SOIC-16

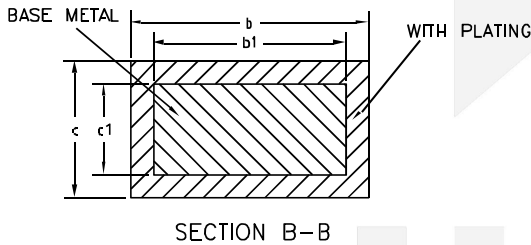
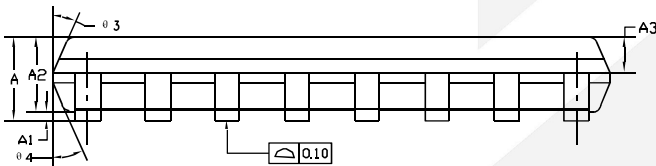
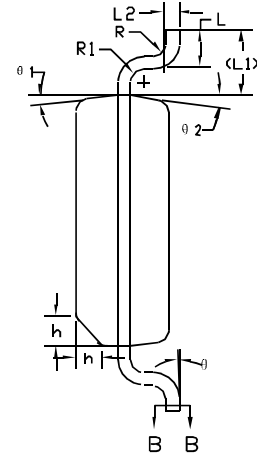
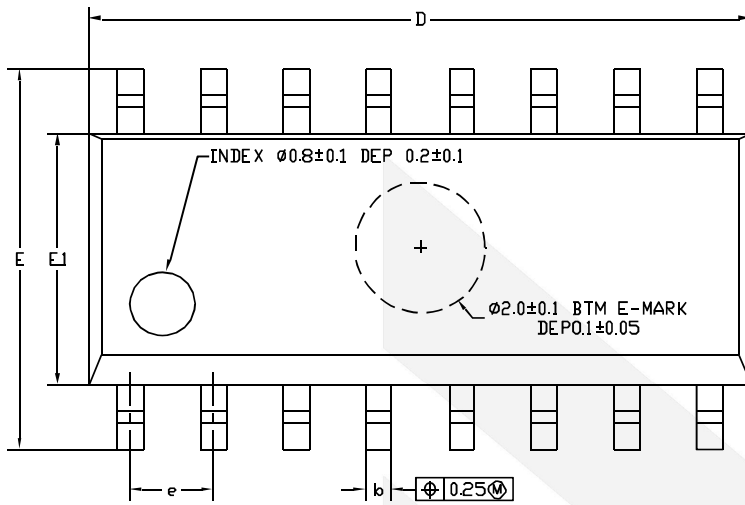

COMMON DIMENSIONS (UNITS OF MEASURE=MILLIMETER)			
Symbol	MIN	NOM	MAX
A	-	-	1.75
A1	0.10	0.15	0.25
A2	1.35	1.45	1.55
A3	0.55	0.65	0.75
b	0.36	-	0.51
b1	0.35	0.40	0.45
c	0.18	-	0.25
c1	0.17	0.20	0.23
D	9.80	9.90	10.00
E	5.80	6.00	6.20
E1	3.80	3.90	4.00
e	1.22	1.27	1.32
L	0.45	0.60	0.80
L1	1.04REF		
L2	0.25BSC		
R	0.07	-	-
R1	0.07	-	-
h	0.30	0.40	0.50
Ø	0°	-	8°
Ø1	6°	8°	10°
Ø2	6°	8°	10°
Ø3	5°	7°	9°
Ø4	5°	7°	9°



DIO2511

2-Vrms Audio Line Driver with Integrated 6th-Order SDVideo Filter

Physical Dimensions: TSSOP-16

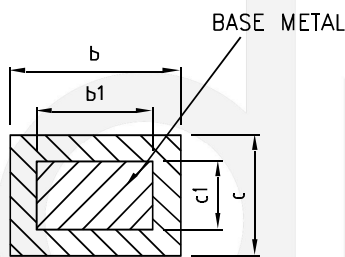
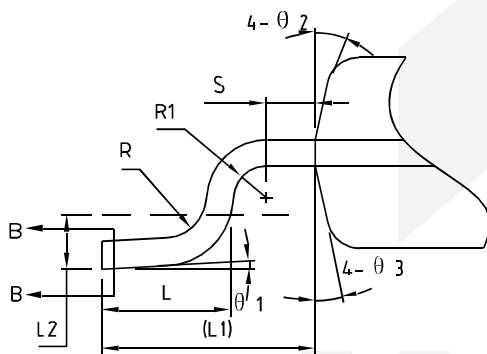
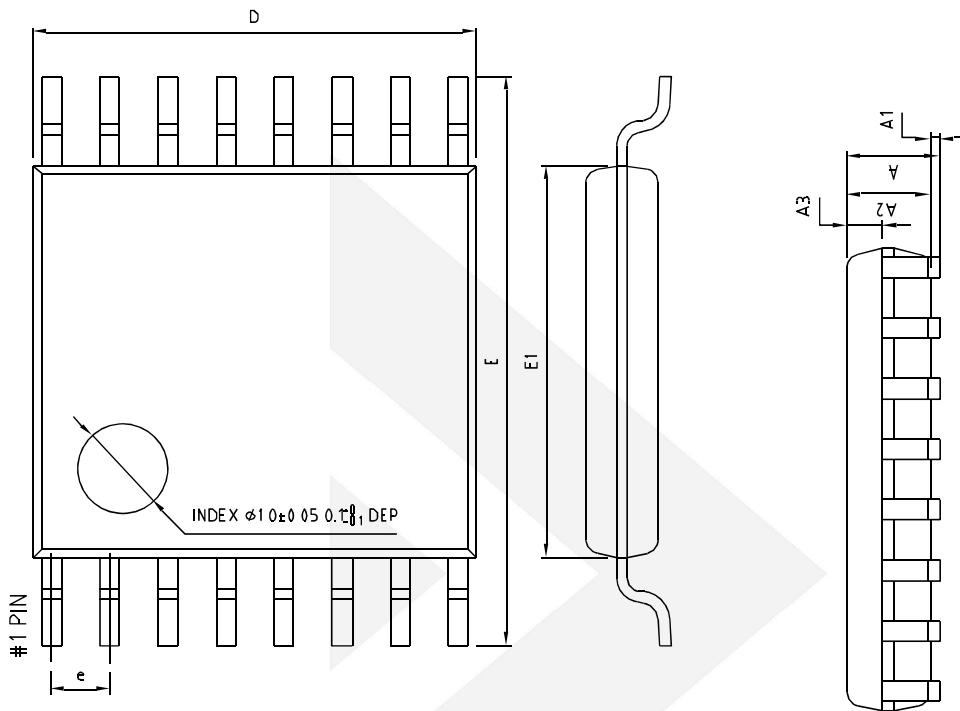

SECTION B-B

COMMON DIMENSIONS (UNITS OF MEASURE=MILLIMETER)			
Symbol	MIN	NOM	MAX
A	-	-	1.10
A1	0.05	-	0.15
A2	0.80	0.90	1.00
A3	0.29	0.39	0.49
b	0.20	-	0.28
b1	0.20	0.22	0.24
c	0.10	-	0.19
c1	0.10	0.13	0.15
D	4.86	4.96	5.06
E	6.20	6.40	6.60
E1	4.30	4.40	4.50
e	0.55	0.65	0.75
L	0.45	0.60	0.75
L1	1.00REF		
L2	0.25BSC		
R	0.09	-	-
R1	0.09	-	-
S	0.20	-	-
θ1	0°	-	8°
θ2	10°	12°	14°
θ3	10°	12°	14°



DIO2511

2-Vrms Audio Line Driver with Integrated 6th -Order SDVideo Filter

CONTACT US

Dioo is a professional design and sales corporation for high-quality and performance analog semiconductors. The company focuses on industry markets, such as, cell phone, handheld products, laptop, and medical equipment and so on. Dioo's product families include analog signal processing and amplifying, LED drivers and charger IC. Go to <http://www.dioo.com> for a complete list of Dioo product families.

For additional product information, or full datasheet, please contact with our Sales Department or Representatives.

dioo

X-ON Electronics

Largest Supplier of Electrical and Electronic Components

Click to view similar products for [Audio Amplifiers](#) category:

Click to view products by [Dioo](#) manufacturer:

Other Similar products are found below :

[LV47002P-E](#) [MP7747DQ-LF-P](#) [AZ386MTR-E1](#) [NCP2811AFCT1G](#) [NCP2890AFCT2G](#) [NJM8068RB1-TE1](#) [NJW1194V-TE1](#) [LA4282-E](#)
[LA4814JA-AE](#) [LC706200CM](#) [SSM2377ACBZ-R7](#) [FDA2100LV](#) [TDA2541](#) [TDA7385H](#) [TDA7391LV](#) [TDA7575BPDTR](#) [TDA7718NTR](#)
[IS31AP2121-LQLS1](#) [IS31AP4915A-QFLS2-TR](#) [LA74309FA-BH](#) [421067X](#) [480263C](#) [NCP2820FCT2G](#) [STPA001](#) [TDA1515AQ](#) [TDA1520B](#)
[TDA1591T](#) [TDA2051H](#) [TDA4850](#) [TDA7391PDUTR](#) [TDA7563BH](#) [TDA7718B](#) [LA4425F-E](#) [LA4742-E](#) [TDA7391PDU](#)
[TDA7491MV13TR](#) [TDA749213TR](#) [TDA7563AH](#) [TDA7850H](#) [STK433-070GN-E](#) [E-TDA7391PDTR](#) [SSM2529ACBZ-R7](#) [SSM2518CBZ-](#)
[R7](#) [MAX9890BEBL+T](#) [MAX98303EWE+T](#) [MAX98358EWL+](#) [MAX98304DEWL+T](#) [MAX97220DETE+T](#) [TS4962MEIJT](#) [TS4990EIJT](#)