

DIO271

One-Channel, 11MHz, 6th-Order Standard Definition Video Filter

Features

- One-ch 6th-order 11MHz SD filters
- 6dB Output Driver Gain and Drive Dual Video Load
- Transparent Input Clamping
- AC or DC Coupled Inputs
- AC or DC Coupled Outputs
- Operates from 3.135 to 5.5V Single Power Supply
- Low Power 8mA
- RoHS or Green SOIC-8 and SC70-5 Package
- 8kV ESD protection

Applications

- DVD Players
- Video Amplifiers
- Cable set-top boxes
- Personal Video Recorders
- Communications Devices
- Video on Demand

Descriptions

DIO271 is a low voltage, one channel video amplifier with integrated reconstruction filter and input clamps. DIO271 provides improved image quality compared with passive LC filters and discrete drivers solution, especially suited for standard definition video signals, such as television and set-top box applications.

DIO271 can be directly driven by a DC-coupled DAC output or an AC-coupled signal. Internal diode-like clamps and bias circuitry may be used if AC-coupled inputs are required. The output in DIO271 can also drive AC or DC coupled single (150Ω) or dual (75Ω) loads. The DC coupling capacitors can be removed.

Block Diagram

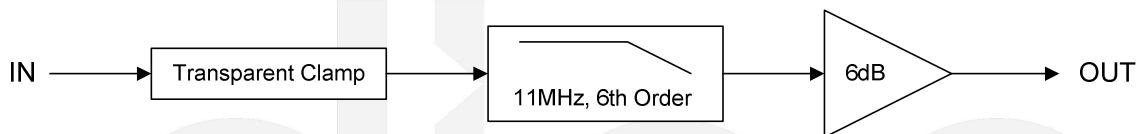

Ordering Information

Order Part Number	Top Marking		T _A	Package	
DIO271SC5	YWXH	RoHS or Green	-40 to +85°C	SC70-5	Tape & Reel, 3000
DIO271CS8	DIO271	RoHS or Green	-40 to +85°C	SOIC-8	Tape & Reel, 2500

Marking Definition

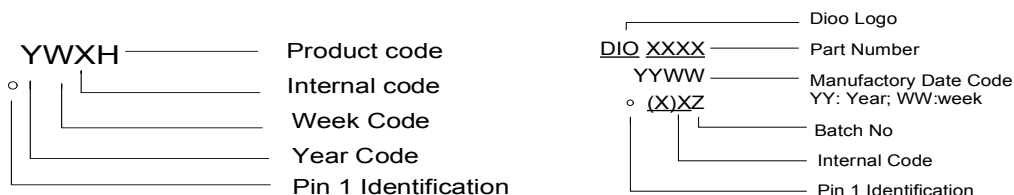

Pin Assignments

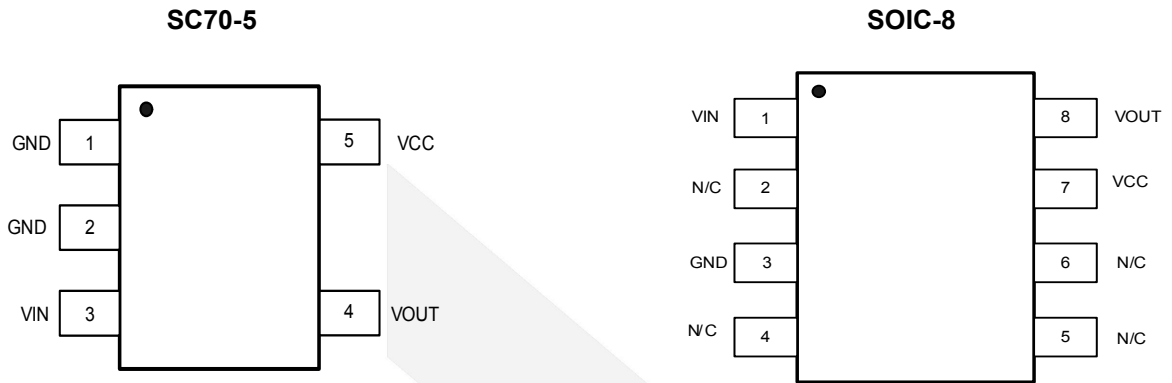

Figure 1 Pin Assignment

Pin Description

Pin name	Description
VIN	Video input
VCC	Power supply
GND	Ground
VOUT	Filtered output
N/C	No Connect



Absolute Maximum Ratings

Stresses beyond those listed under "Absolute Maximum Rating" may cause permanent damage to the device. These are stress ratings only and functional operation of the device at these or any other condition beyond those indicated in the operational sections of the specifications is not implied. Exposure to absolute maximum rating conditions for extended periods may affect device reliability.

Parameter		Rating	Unit
Supply Voltage		0 to 6.0	V
Input Voltage		-0.3 to VCC+0.3	V
Storage Temperature Range		-65 to 150	°C
Junction Temperature		150	°C
Lead Temperature Range		260	°C
ESD	HBM, JEDEC: JESD22-A114	8	kV
	CDM, JEDEC: JESD22-C101	2	

Recommended Operating Conditions

The Recommended Operating Conditions table defines the conditions for actual device operation to ensure optimal performance to the datasheet specifications. DIOO does not recommend exceeding them or designing to Absolute Maximum Ratings.

Parameter		Rating	Unit
Supply Voltage		3.135 to 5.5	V
Operating Temperature Range		-40 to 85	°C



Electrical Characteristics

Typical value: $T_A = 25^\circ\text{C}$, $V_{CC}=5\text{V}$, $R_{SOURCE}=37.5\Omega$, $R_L=150\Omega$ loads; all inputs are AC couple with $0.1\mu\text{F}$; all outputs are AC coupled with $220\mu\text{F}$; unless otherwise specified.

Symbol	Parameter	Conditions	Min.	Typ.	Max.	Unit
DC ELECTRICAL CHARACTERISTICS						
I_{CC}	Supply Current			8	12	mA
V_{IN}	Video Input Voltage Range		GND	1.4		V_{PP}
PSRR	Power Supply Rejection			-50		dB
DYNAMIC PERFORMANCE						
AV	Channel Gain		5.8	6.0	6.2	dB
f_{1dB}	-1dB Bandwidth		8.0	10.5		MHz
f_{3dB}	-3dB Bandwidth		9	11.8		MHz
	Filter Response	$f=27\text{MHz}$		-40		dB
DG	Differential Gain			0.2		%
DP	Differential Phase			0.36		$^\circ$
THD	Output Distortion	$f=1\text{MHz}$		0.38		%
X_{TALK}	Crosstalk	$f=1\text{MHz}$		-74		dB
SNR	Signal to Noise Ratio			70		dB
	Group Delay	$f=400\text{kHz}, 6.5\text{MHz}$		20		ns
CLG_SD	Chroma Luma Gain	$f=3.58\text{MHz}$ ref to SD in at 400kHz	95	100	105	%
CLD_SD	Chroma Luma Delay	$f=3.58\text{MHz}$ ref to SD in at 400kHz		5.5		ns

Notes: $SNR=20 \cdot \log(714\text{mV} / \text{rms noise})$.

Specifications subject to change without notice.

Typical Performance Characteristics

At $T_A = 25^\circ\text{C}$, $V_{CC}=5\text{V}$, $R_{\text{SOURCE}}=37.5\Omega$, $R_L=150\Omega$ loads unless otherwise noted.

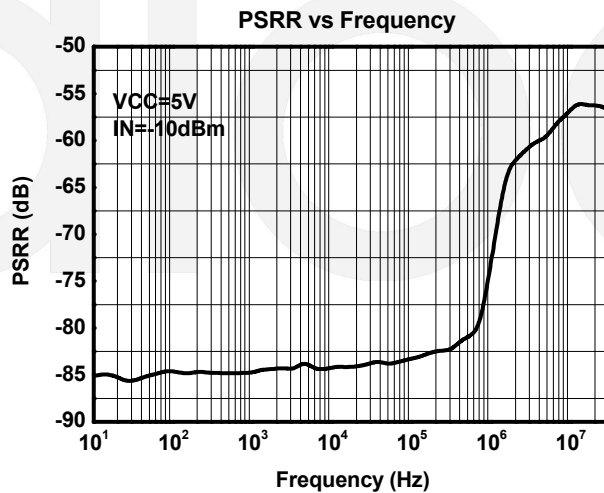
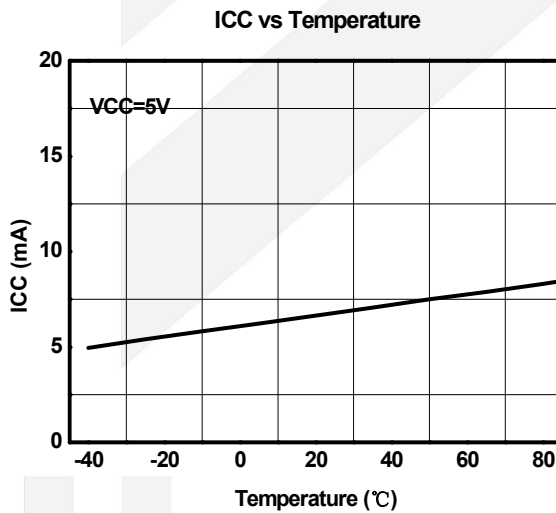
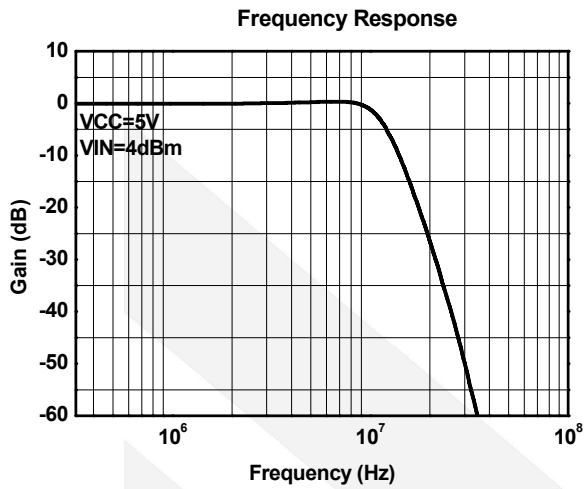

Typical Application

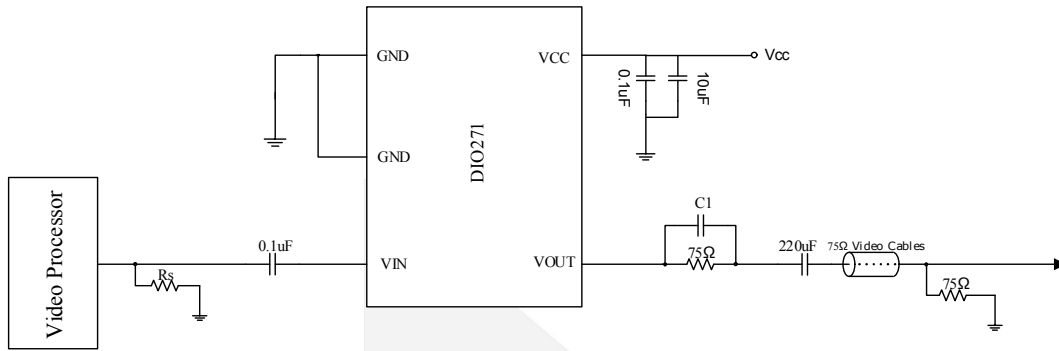

Figure 2 Input and Output AC-Coupling Application

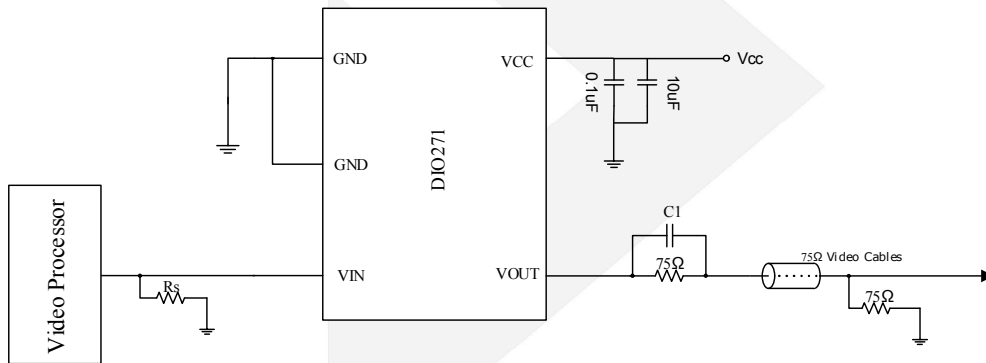

Figure 3 Input and Output DC-Coupling Application

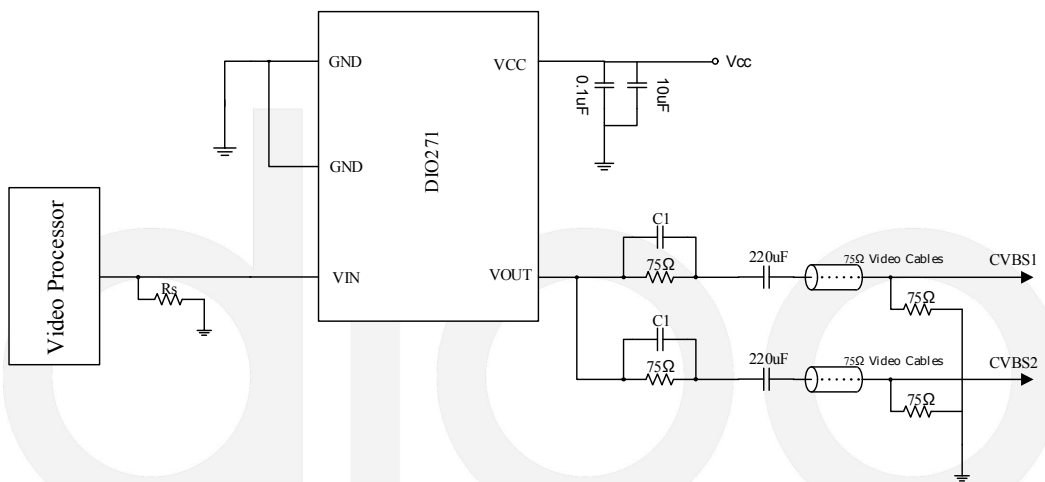
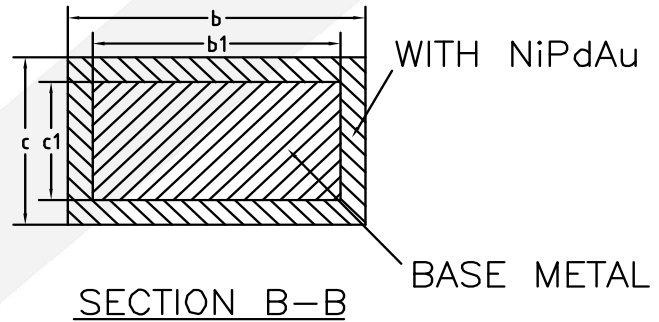
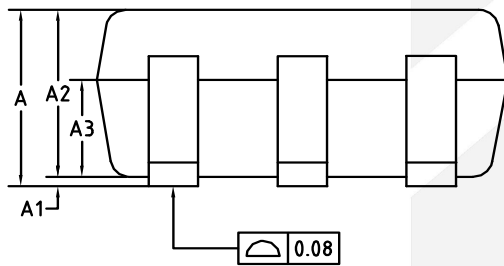
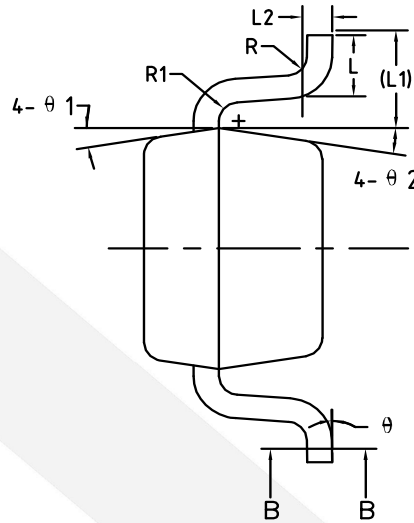
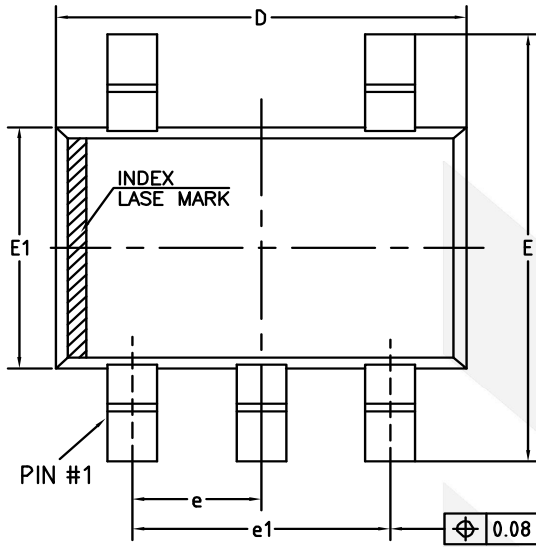

Figure 4 Input DC-Coupling Application and Output AC-Coupling with Double Load

Note: The value of C1 is recommended 2 to 4pF.

Physical Dimensions: SC70-5



COMMON DIMENSIONS (UNITS OF MEASURE=MILLIMETER)			
Symbol	MIN	NOM	MAX
A	0.85	-	1.05
A1	0	-	0.10
A2	0.80	0.90	1.00
A3	0.47	0.52	0.57
b	0.22	-	0.29
b1	0.22	0.25	0.28
c	0.115	-	0.15
c1	0.115	0.13	0.14
D	2.02	2.07	2.12
E	2.20	2.30	2.40
E1	1.25	1.30	1.35
e	0.65BSC		
e1	1.30BSC		
L	0.28	0.33	0.38
L1	0.50REF		
L2	0.15BSC		
R	0.10	-	-
R1	0.10	-	0.25
θ	0°	-	8°
θ1	6°	9°	12°
θ2	6°	9°	12°

Physical Dimensions: SOIC-8

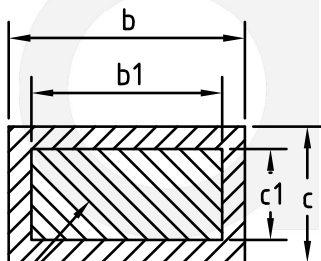
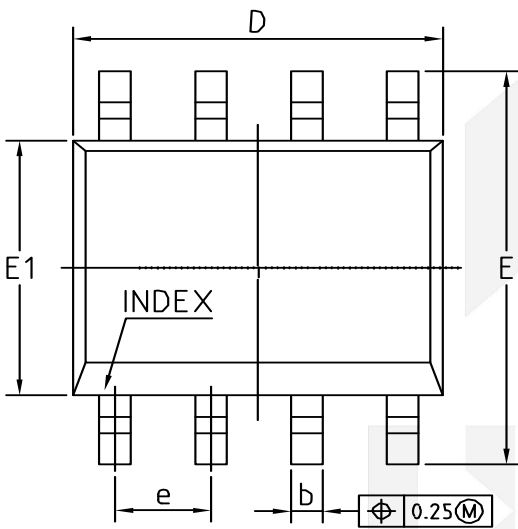
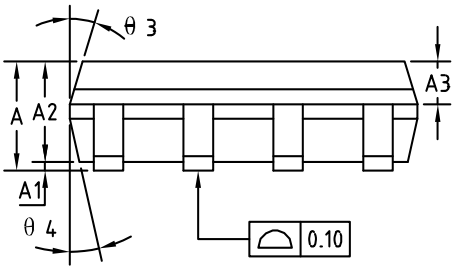
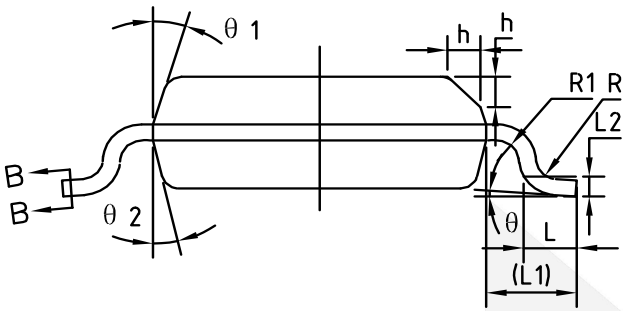

BASE METAL

SECTION B-B

COMMON DIMENSIONS (UNITS OF MEASURE=MILLIMETER)			
Symbol	MIN	NOM	MAX
A	1.35	1.55	1.75
A1	0.10	0.15	0.25
A2	1.25	1.40	1.65
A3	0.50	0.60	0.70
b	0.38	-	0.51
b1	0.37	0.42	0.47
c	0.17	-	0.25
c1	0.17	0.20	0.23
D	4.80	4.90	5.00
E	5.80	6.00	6.20
E1	3.80	3.90	4.00
e	1.27BSC		
L	0.45	0.60	0.80
L1	1.04REF		
L2	0.25BSC		
R	0.07	-	-
R1	0.07	-	-
h	0.30	0.40	0.50
θ	0°	-	8°
θ1	15°	17°	19°
θ2	11°	13°	15°
θ3	15°	17°	19°
θ4	11°	13°	15°

CONTACT US

Dioo is a professional design and sales corporation for high-quality and performance analog semiconductors. The company focuses on industry markets, such as, cell phone, handheld products, laptop, and medical equipment and so on. Dioo's product families include analog signal processing and amplifying, LED drivers and charger IC. Go to <http://www.dioo.com> for a complete list of Dioo product families.

For additional product information, or full datasheet, please contact with our Sales Department or Representatives.



X-ON Electronics

Largest Supplier of Electrical and Electronic Components

Click to view similar products for [Video ICs category](#):

Click to view products by [Dioo manufacturer](#):

Other Similar products are found below :

[ADV7343WBSTZ](#) [TW2964-LA2-CR](#) [TW9903-FB](#) [TW9919-PE1-GR](#) [TW9960-TA1-GR](#) [LA9520V-TLM-E](#) [TW9910-NA2-GR](#) [TW9900-TA1-GR](#) [ADV7625KBCZ-8](#) [ADV7626KBCZ-8](#) [MAX9406ETM+T](#) [PI3HDX414FCEEX](#) [PI3HDX511FZLEX](#) [M31245G-15](#)
[PI3HDX511DZLEX](#) [MAX4895EETE+T](#) [M23428G-33](#) [PI7VD9008ABHFDE](#) [TW2984-NA2-CR](#) [ADV7186BBCZ-RL](#) [ADV7186BBCZ-TL](#)
[PI3HDMI521FBE](#) [ADV7186BBCZ-T-RL](#) [ADV8003KBCZ-7C](#) [LT6554IGN#PBF](#) [M21324G-13](#) [GS12181-INE3](#) [PI3VDP411LSAZBEX](#)
[PI3VDP411LSTZBEX](#) [M23145G-14](#) [PI3VDP411LSRZBEX](#) [PI3HDX511EZLSEX](#) [TW2835-BA1-GR](#) [ISL59913IRZ](#) [TW9910-NB2-GR](#)
[CM5100-01CP](#) [ADV7610BBCZ-RL](#) [BA7653AFV-E2](#) [BA7654F-E2](#) [BA7657F-E2](#) [BH76331FVM-TR](#) [BH76332FVM-TR](#) [BH76363FV-E2](#)
[TVP5160PNP](#) [MAX9597CTI+](#) [BA7602F-E2](#) [BA7606FS-E2](#) [BA7612F-E2](#) [BA7626F-E2](#) [BA7653AF-E2](#)