

## DIO3000

# DPDT USB 2.0 High-Speed and Mobile High-Definition Link (MHL) 5.8GHz Switch

### Features

- Wide  $V_{CC}$  Input Voltage Range: 2.3V to 5.5V
- USB Channel:
  - Bandwidth (-3dB): 5.8GHz
  - $R_{ON}$  (Typ.): 4.6 $\Omega$
  - $C_{ON}$  (Typ.): 1.2pF
- Mobile High Definition Link (MHL) Channel:
  - Bandwidth (-3dB): 5.5GHz
  - $R_{ON}$  (Typ.): 5.7 $\Omega$
  - $C_{ON}$  (Typ.): 1.4pF
- Ultra-Low Power Consumption: 20 $\mu$ A (Typ.)
- Additional Features:
  - Power-off Protection: Low Current Leakage in Powered-Down State ( $V_{CC} = 0V$ )
  - Overvoltage Tolerance (OVT) on all I/O Pins up to 5.5V
  - Overvoltage Protection of 9V Short to Data Pins
- Packaged in QFN2\*1.5-10

### Applications

- Portable Instrumentation
- Digital Still Cameras
- Tablets
- Mobile phones

### Descriptions

The DIO3000 is a dual single-pole, double throw (SPDT) switch with a Mobile High-Definition Link (MHL) switch and an USB2.0 High-Speed (480Mbps) switch housed in the same package. Wide bandwidth of this product allows the sharing of the USB connector for both MHL video signals and USB data transmission.

The DIO3000 offers wide  $V_{CC}$  input voltage range of 2.3V to 5.5V and features overvoltage tolerance (OVT) function, which allows the I/O pins to withstand overvoltage conditions (up to 5.5V). The power-off protection feature forces all I/O pins to be in high-impedance mode when power is not present or 0V without excessive leakage current. 1.8V compatible control logic of DIO3000 allows the direct interface with the General-Purpose I/O (GPIO) of the baseband processor.

The DIO3000 is housed in small QFN2\*1.5-10, which makes it a perfect candidate to be used in handheld applications.

### Block Diagram

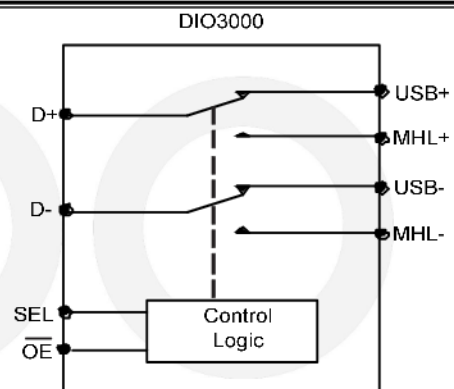

### Ordering Information

Order Part Number	Top Marking		$T_A$	Package
DIO3000QN10	YW3C	Green	-40 to 85°C	QFN2*1.5-10 Tape & Reel,3000

## Pin Assignment

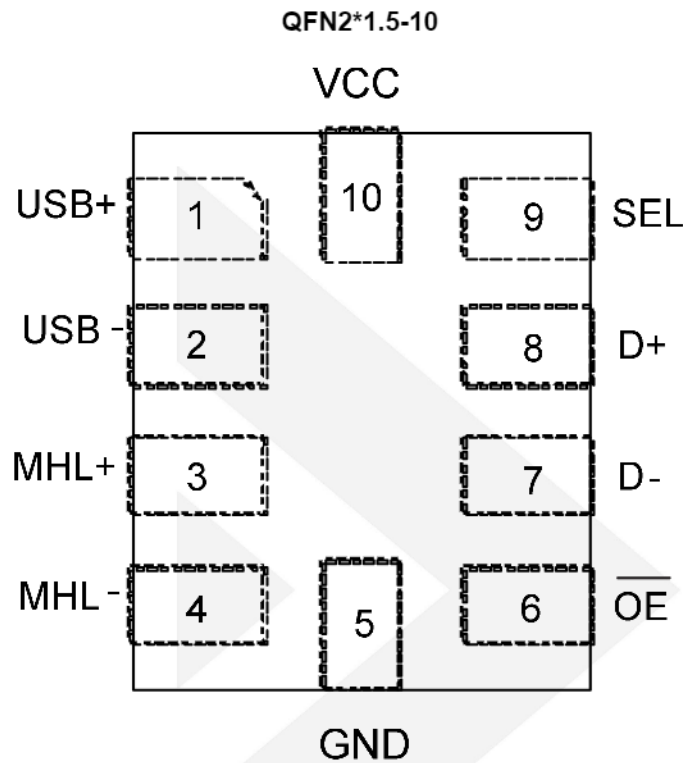

Figure 1. Top View

## Pin Descriptions

Pin Name	Direction	Description
USB+	I/O	USB Data Link (Differential+)
USB-	I/O	USB Data Link (Differential-)
MHL+	I/O	MHL Data Link (Differential+)
MHL-	I/O	MHL Data Link (Differential-)
GND	-	Ground
$\overline{\text{OE}}$	I	Output Enable (Active Low)
D-	I/O	Switch Output (Differential-)
D+	I/O	Switch Output (Differential+)
SEL	I	Switch Select (LOW=D+/D- To USB+/USBHIGH=D+/D- To MHL+/MHL-)
VCC	-	Power Supply Pin

## Absolute Maximum Ratings

Stresses beyond those listed under "Absolute Maximum Rating" may cause permanent damage to the device. These are stress ratings only and functional operation of the device at these or any other condition beyond those indicated in the operational sections of the specifications is not implied. Exposure to absolute maximum rating conditions for extended periods may affect device reliability.

Symbol	Parameter	Min	Max	Unit
V <sub>CC</sub>	Supply Voltage	-0.3	6	V
V <sub>I/O</sub>	Input-Output DC Voltage	-0.3	6	V
V <sub>D-</sub>	D- DC Voltage <sup>(1)</sup>	-0.3	9	V
V <sub>I</sub>	Digital Input Voltage (SEL, $\overline{OE}$ )	-0.3	6	V
I <sub>K</sub>	Input-Output Port Diode Current (V <sub>I/O</sub> <0)	-50		mA
I <sub>IK</sub>	Digital Logic Input Clamp Current (V <sub>I</sub> <0)	-50		mA
I <sub>CC</sub>	Continuous Current Through VCC		100	mA
I <sub>GND</sub>	Continuous Current Through GND	-100		mA
T <sub>stg</sub>	Storage Temperature	-65	150	°C
ESD	Human Body Model (HBM)	-5500	5500	V

- (1) This rating only applies to the D- pin with respect to GND. VCC must be powered within the recommended operating conditions of 2.3V to 5.5V and the  $\overline{OE}$  pin must be logic high for this rating to be applicable. Any condition where VCC is unpowered or the  $\overline{OE}$  pin is not high must reference the rest of the Absolute Maximum Ratings Table.

## Recommend Operating Conditions

The Recommended Operating Conditions table defines the conditions for actual device operation. Recommended Operating conditions are specified to ensure optimal performance to the datasheet specifications. DIOO does not Recommend exceeding them or designing to Absolute Maximum Ratings.

Symbol	Parameter	Rating	Unit
V <sub>CC</sub>	Supply Voltage	2.3to 5.5	V
V <sub>I/O (USB)</sub>	Analog Voltage	0 to V <sub>CC</sub>	V
V <sub>I/O (MHL)</sub>			
V <sub>I</sub>	Digital Input Voltage (SEL, $\overline{OE}$ )	0 to V <sub>CC</sub>	V
T <sub>RAMP (VCC)</sub>	Power Supply Ramp Time Requirement (V <sub>CC</sub> )	100 to 1000	µs/V
T <sub>A</sub>	Operating Free-Air Temperature	-40 to 85	°C
R <sub>θJA</sub>	Junction-To-Ambient Thermal Resistance	193	°C/W
R <sub>θJC(top)</sub>	Junction-To-Case (Top) Thermal Resistance	96	°C/W
R <sub>θJB</sub>	Junction-To-Board Thermal Resistance	118	°C/W

$\theta_{JT}$	Junction-To-Top Characterization Parameter	7.8	$^{\circ}\text{C/W}$
$\theta_{JB}$	Junction-To-Board Characterization Parameter	118	$^{\circ}\text{C/W}$

## Electrical Characteristics

$T_A = -40^{\circ}\text{C}$  to  $85^{\circ}\text{C}$ , Typical values are at  $V_{CC} = 3.3\text{V}$ ,  $T_A = 25^{\circ}\text{C}$ , (unless otherwise noted)

Symbol	Parameter	Conditions	Min	Typ	Max	Unit
<b>MHL SWITCH</b>						
$R_{ON}$	ON-State Resistance	$V_{CC} = 2.7\text{V}$ , $V_{IO} = 1.65\text{V}$ , $I_{ON} = -8\text{mA}$		5.7	9	$\Omega$
		$V_{CC} = 2.3\text{V}$ , $V_{IO} = 1.65\text{V}$ , $I_{ON} = -8\text{mA}$		5.7	9.5	
$\Delta R_{ON}$	ON-State Resistance Match between + and - Paths	$V_{CC} = 2.3\text{V}$ , $V_{IO} = 1.65\text{V}$ , $I_{ON} = -8\text{mA}$		0.1		$\Omega$
$I_{OZ}$	OFF Leakage Current	$V_{CC} = 5\text{V}$ , Switch OFF, $V_{MHL\pm} = 1.65\text{V}$ to $3.45\text{V}$ , $V_{D\pm} = 0\text{V}$	-2		2	$\mu\text{A}$
$I_{ON}$	ON Leakage Current	$V_{CC} = 5\text{V}$ , Switch ON, $V_{MHL\pm} = 1.65\text{V}$ to $3.45\text{V}$ , $V_{D\pm} = \text{NC}$	-2		2	$\mu\text{A}$
$Z_{ON\_GND}$	ON-State Impedance to GND	$V_{IO} = 0\text{V}$ to $1.8\text{V}$ , $T_A = -40^{\circ}\text{C}$ to $85^{\circ}\text{C}$	7			$\text{M}\Omega$
<b>USB SWITCH</b>						
$R_{ON}$	ON-State Resistance	$V_{CC} = 2.3\text{V}$ , $V_{IO} = 0.4\text{V}$ , $I_{ON} = -8\text{mA}$		4.6	7.5	$\Omega$
$\Delta R_{ON}$	ON-State Resistance Match between + and - Paths	$V_{CC} = 2.3\text{V}$ , $V_{IO} = 0.4\text{V}$ , $I_{ON} = -8\text{mA}$		0.1		$\Omega$
$I_{OZ}$	OFF Leakage Current	$V_{CC} = 5\text{V}$ , Switch OFF, $V_{USB\pm} = 0\text{V}$ to $3.6\text{V}$ , $V_{D\pm} = 0\text{V}$	-2		2	$\mu\text{A}$
$I_{ON}$	ON Leakage Current	$V_{CC} = 5\text{V}$ , Switch ON, $V_{USB\pm} = 0\text{V}$ to $3.6\text{V}$ , $V_{D\pm} = \text{NC}$	-2		2	$\mu\text{A}$
$Z_{ON\_GND}$	ON-State Impedance to GND	$V_{IO} = 0\text{V}$ to $1.8\text{V}$ , $T_A = -40^{\circ}\text{C}$ to $85^{\circ}\text{C}$	7			$\text{M}\Omega$
<b>DIGITAL CONTROL INPUTS (SEL, <math>\overline{\text{OE}}</math>)</b>						
$V_{IH}$	Input Logic High	$V_{CC} = 2.3\text{V}$ to $5\text{V}$	1.3			V
$V_{IL}$	Input Logic Low	$V_{CC} = 2.3\text{V}$ to $5\text{V}$			0.6	V
$I_{IN}$	Input Leakage Current	$V_{CC} = 5\text{V}$ , $V_{IO} = 0\text{V}$ to $3.6\text{V}$ , $V_{IN} = 0$ to $5\text{V}$	-10		10	$\mu\text{A}$

## Dynamic Characteristics

Overoperating free-air temperature range (unless otherwise noted)

Symbol	Parameter	Conditions	Min	Typ	Max	Unit
$C_{ON(MHL)}$	MHL Path ON Capacitance	$V_{CC}=3.3V$ , $V_{IO}=0$ or $3.3V$ , $f=240MHz$ , Switch ON		1.4	1.8	pF
$C_{ON(USB)}$	USB Path ON Capacitance	$V_{CC}=3.3V$ , $V_{IO}=0$ or $3.3V$ , $f=240MHz$ , Switch ON		1.2	1.6	pF
$C_I$	Digital Input Capacitance	$V_{CC}=3.3V$ , $V_I=0$ or $2V$		2.2		pF
$O_{ISO}$	OFF Isolation	$V_{CC}=2.3V$ to $5V$ , $R_L=50\Omega$ , $f=240MHz$ , Switch OFF		-36		dB
$X_{TALK}$	Crosstalk	$V_{CC}=2.3V$ to $5V$ , $R_L=50\Omega$ , $f=240MHz$ , Switch ON		-42		dB
$B_{W(MHL)}$	MHL Path -3dB Bandwidth	$V_{CC}=2.3V$ to $5V$ , $R_L=50\Omega$ , $f=240MHz$ , Switch ON		5.5		GHz
$B_{W(USB)}$	USB Path -3dB Bandwidth	$V_{CC}=2.3V$ to $5V$ , $R_L=50\Omega$ , $f=240MHz$ , Switch ON		5.8		GHz
<b>SUPPLY</b>						
$V_{CC}$	Power Supply Voltage		2.3		5.5	V
$I_{CC}$	Positive Supply Current	$V_{CC}=5V$ , $V_{IN}=V_{CC}$ or $GND$ , $V_{IO}=0V$ , Switch ON or OFF		20	40	$\mu A$
$I_{CC, HZ}$	Power Supply Current In High-Z Mode	$V_{CC}=5V$ , $V_{IN}=V_{CC}$ or $GND$ , $V_{IO}=0V$ , Switch ON or OFF, $\overline{OE}=H$		1	5	$\mu A$

## Timing Requirements

Symbol	Conditions		Min	Nom	Max	Unit
$t_{switch}$	Switching Time (SEL To Output)	See Figure 2		60		ns
$t_{ZH, ZL(MHL)}$	MHL Enable Time ( $\overline{OE}$ To Output)	$V_{IO}=3.3V$ or $0V$	$R_L=50\Omega$ , $C_L=5pF$ , $V_{CC}=2.3V$ to $5V$	7		$\mu s$
$t_{HZ, LZ(MHL)}$	MHL Disable Time ( $\overline{OE}$ To Output)			22		ns
$t_{ZH, ZL(USB)}$	USB Enable Time ( $\overline{OE}$ To Output)	$V_{IO}=0.8V$ or $0V$		7		$\mu s$
$t_{HZ, LZ(USB)}$	USB Disable Time ( $\overline{OE}$ To Output)			17		ns

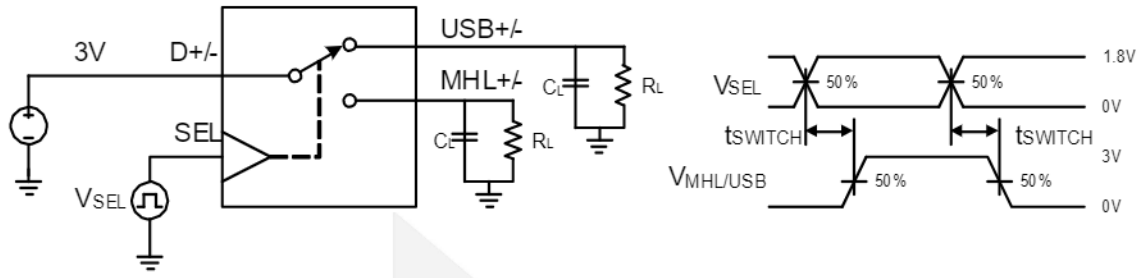

- (1) All input pulses are supplied by generators having the following characteristics:  $PRR \leq 10\text{MHz}$ ,  $Z_0 = 50\Omega$ ,  $t_r < 5\text{ns}$ ,  $t_f < 5\text{ns}$ .
- (2)  $C_L$  includes probe and jig capacitance.

Figure 2. Timing Diagram

## Typical Performance Characteristics

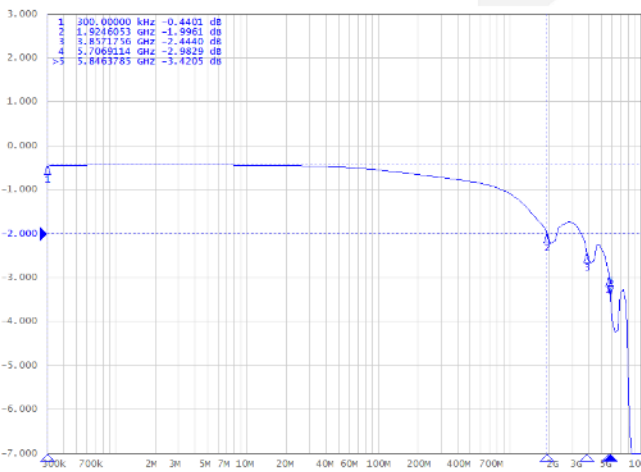

Figure 3. Differential S21 vs Frequency USB Switch

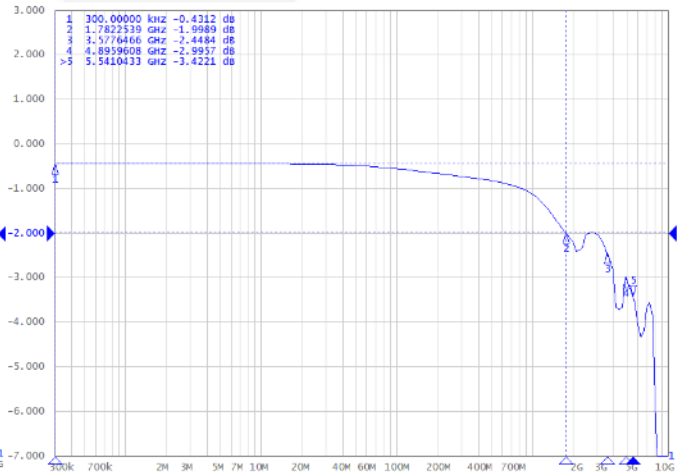

Figure 4. Differential S21 vs Frequency MHL Switch

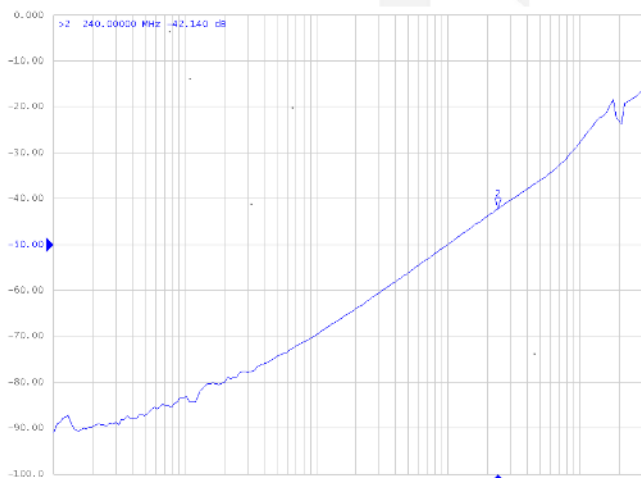

Figure 5. CrossTalk Vs Frequency for USB Path

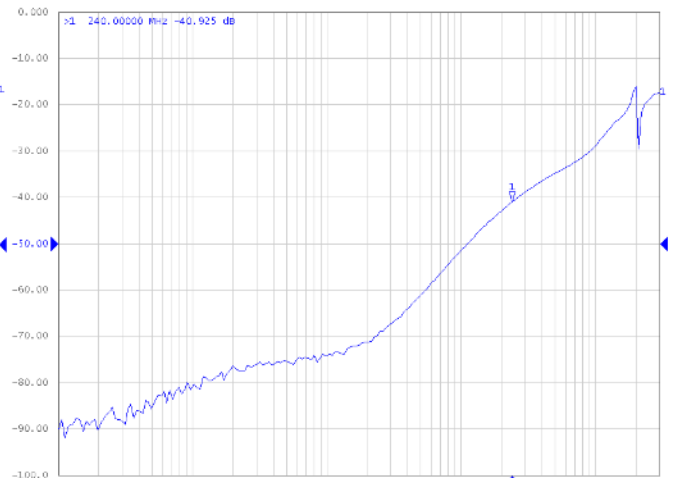

Figure 6. CrossTalk Vs Frequency for MHL Path



Typical Performance Characteristics (Continued)

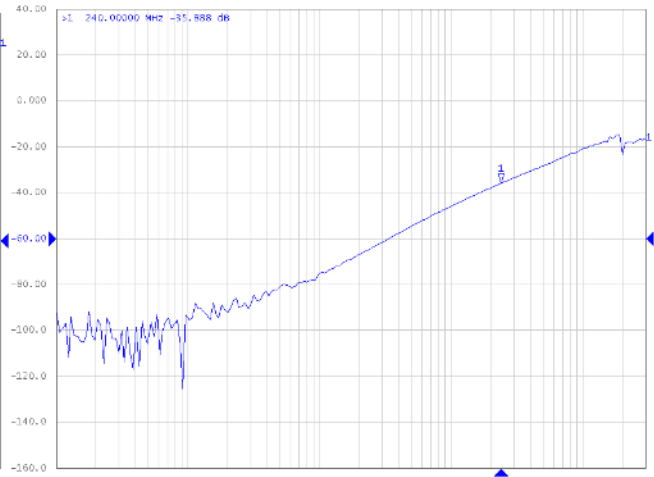
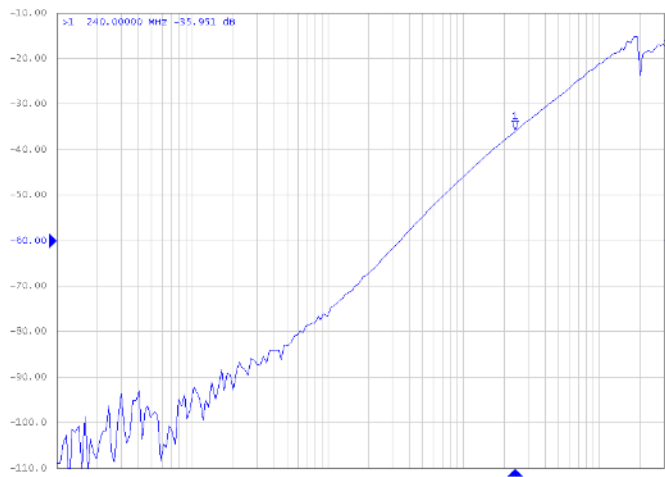

Figure 7. Off Isolation Vs Frequency for USB Path

Figure 8. Off Isolation Vs Frequency for MHL Path

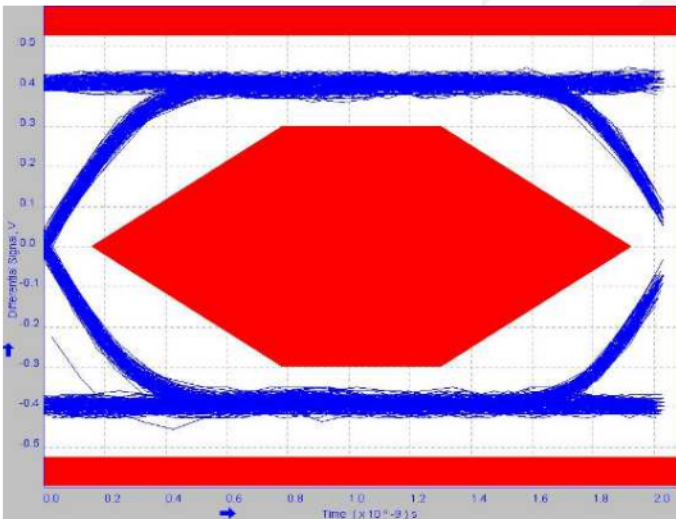
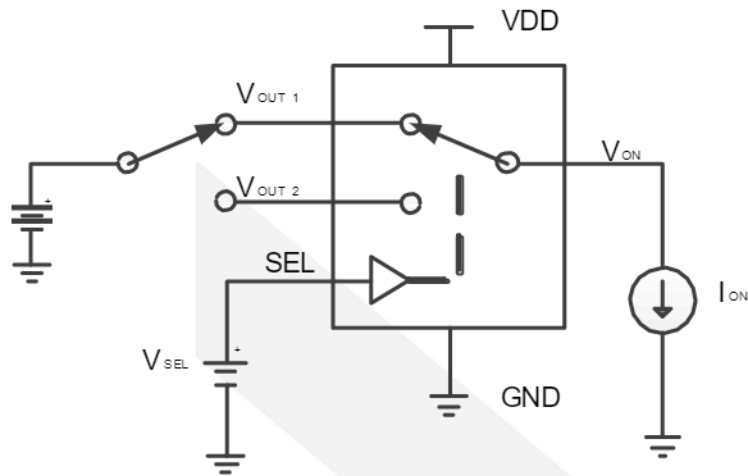

Figure 9. 480-Mbps USB2.0 Eye Pattern for USB Switch With DIO3000

## Application Information



Channel ON,  $R_{ON} = (V_{ON} - V_{I/O1}) / I_{ON}$  or  $(V_{ON} - V_{I/O2}) / I_{ON}$ ,  $V_{SEL} = H$  or  $L$

**Figure 10. ON-State Resistance ( $R_{ON}$ )**

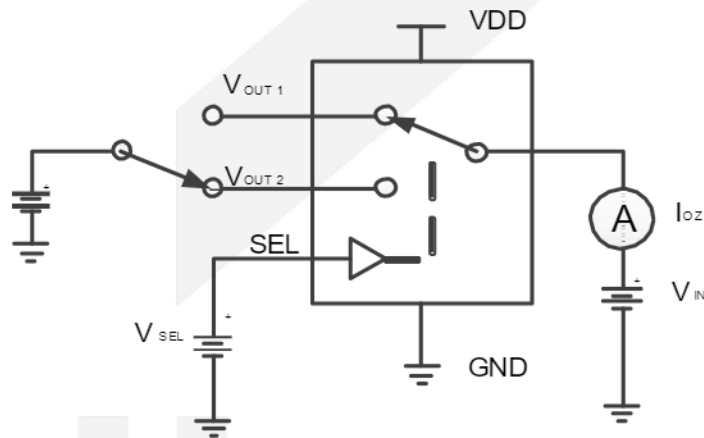

Channel OFF,  $V_{SEL} = H$  or  $L$

**Figure 11. OFF Leakage Current ( $I_{oz}$ )**



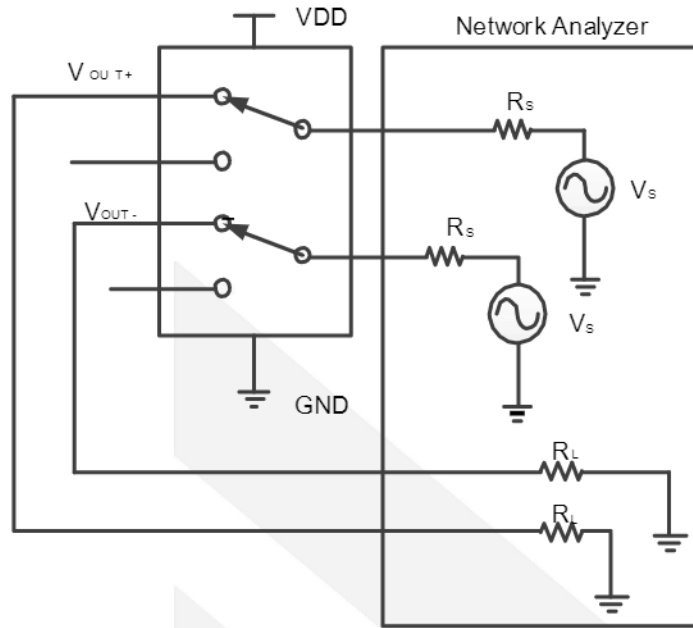

Channel ON,  $V_{SEL}=H$  or  $L$ ,  $R_S=R_L=50\Omega$

**Figure 12. Bandwidth (BW)**

## Detailed Description

### Functional Block Diagram

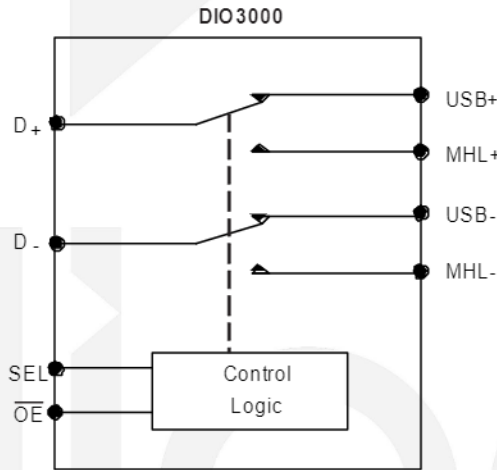

**Table 1. Function Table**

SEL	$\overline{OE}$	SWITCH STATUS
X	High	Both USB and MHL switches in High-Z
Low	Low	D+/D- to USB+/USB-
High	Low	D+/D- to MHL+/MHL-

## Feature Description

### Low Power Mode

The DIO3000 has a low power mode that reduces the power consumption to 1 $\mu$ A while the device is not in use. Set enable pin  $\overline{OE}$  with a logic High signal to put IC in low power mode.

### Overvoltage Protection when 9V Short to D- Pin

The DIO3000 can be used to protect the system when the D- pin is exposed to voltages less than 9V. Voltages higher than 9V may damage the device.

In Figure 13, the system has an application processor (AP) which cannot survive 9V on the USB data lines. The following procedure protects the system and the DIO3000.

1. The AP detects a dedicated charging port (DCP) is connected to the USB port.
2. To disable the switches, the AP pulls the  $\overline{OE}$  pin high. The DIO3000 is now in low-power mode and can protect the AP.
3. The AP negotiates to Charger for a faster charging mode with VBUS up to 9V.

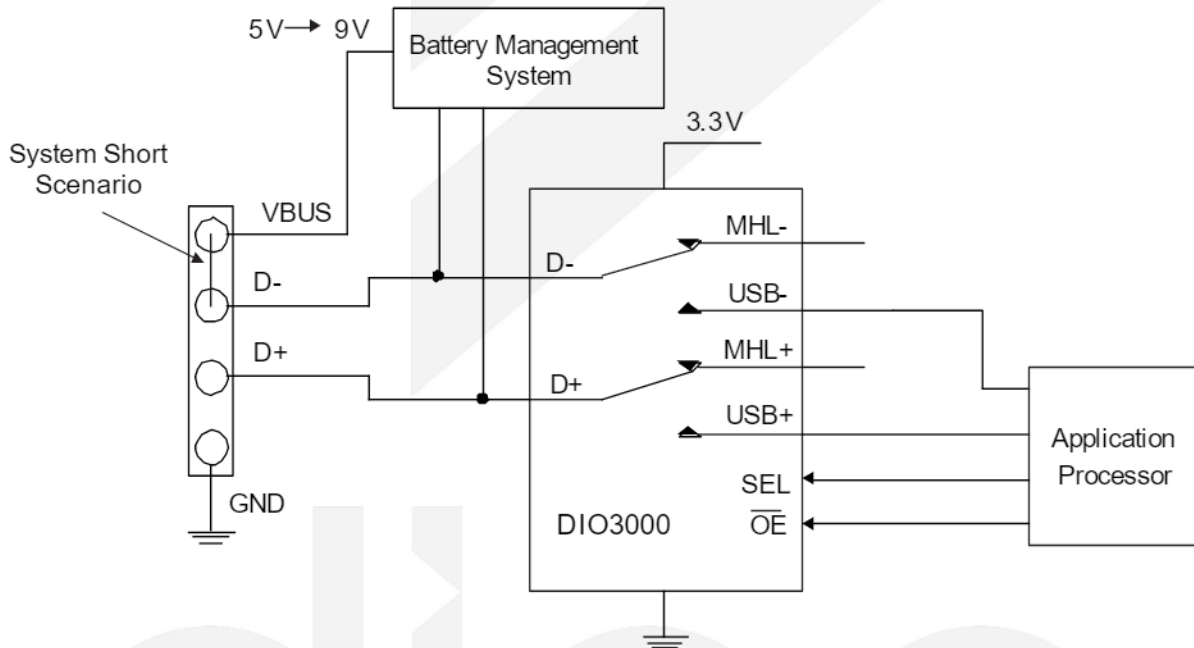

**Figure 13. Potential VBUS to D-Short Example**

### Typical Application

Figure 14 is a typical application of the DIO3000 USB/MHL switch. The DIO3000 has internal 6M $\Omega$  pulldown resistors on  $\overline{OE}$  and SEL. The pulldown on  $\overline{OE}$  pin enables the switch when power is applied. The pulldown on SEL pin ensure the USB channel is selected by default. The DIO3157E is a separate SPDT switch that is used to switch between MHL's CBUS and the USB ID line that is needed for USB OTG (USB On-The-Go) application.

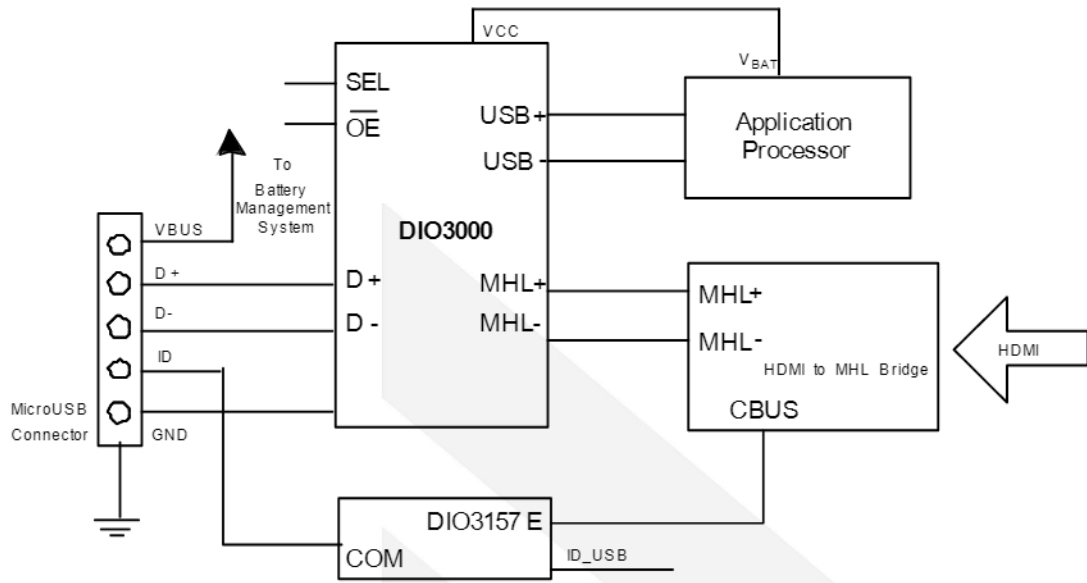

Figure 14. Typical DIO3000 Application



## CONTACT US

Dioo is a professional design and sales corporation for high-quality and performance analog semiconductors. The company focuses on industry markets, such as, cell phone, handheld products, laptop, and medical equipment and so on. Dioo's product families include analog signal processing and amplifying, LED drivers and charger IC. Go to <http://www.dioo.com> for a complete list of Dioo product families.

For additional product information, or full datasheet, please contact with our Sales Department or Representatives.

A large, light gray watermark of the Dioo logo is centered on the page. It consists of a stylized arrow pointing right, followed by the word "dioo" in a lowercase, sans-serif font.

## X-ON Electronics

Largest Supplier of Electrical and Electronic Components

*Click to view similar products for [USB Interface IC](#) category:*

*Click to view products by [Dioo](#) manufacturer:*

Other Similar products are found below :

[TUSB1146RNQT](#) [TUSB1146IRNQT](#) [CY7C65210-24LTXI](#) [CY7C69356-48LTXC](#) [CYUSB2304-68LTXI](#) [CY7C65642-48AXCT](#) [CYPD2119-24LQXI](#) [USB2227-NU-11](#) [USB2251-NU-06](#) [USB3319C-GJ-TR](#) [USB3370B-EZK-TR](#) [USB5537B-4100AKZE](#) [USB3347-CP](#) [USB2230-NU-02](#) [USB2229-NU-02](#) [CG7648AM](#) [W83627HG-AW](#) [CY7C64225-28PVXCT](#) [CY7C65215A-32LTXI](#) [CYPD2120-24LQXI](#) [CYWB0164BB-BZXI](#) [CYWB0224ABS-BZXI](#) [CY7C65211A-24LTXI](#) [USB5807T-I/KD](#) [USB5742-I/2G](#) [USB3331E-GL-TR](#) [USB3321C-GL-TR](#) [USB1T1103MHX](#) [USB1T1103MPX](#) [USB5742/2G](#) [MAX3301EETJ+T](#) [CYPD2122-20FNXIT](#) [CYPD2122-24LQXIT](#) [LIF-UC120-SWG36ITR50](#) [MAX3456EETE+T](#) [LIF-UC120-CM36ITR50](#) [UPD360-C/6HX](#) [USB2228-NU-11](#) [UPD360-B/6HX](#) [PI3EQX7841ZDEX](#) [CYPD4225-40LQXI](#) [LAN7800-I/VSX](#) [UPD360T-B/6HX](#) [UPD360-A/6HX](#) [LAN7800/VSX](#) [MAX20037ATIB/V+](#) [MP5030CGQH-P](#) [USB7056/KDX](#) [STUSBCD01BJR](#) [CY7C65642-28LTXCT](#)