

DIO3157E

Enhanced Low Voltage SPDT Analog Switch with Power on and Power Off Protection

Features

- Over-Voltage Tolerance (OVT) Features at common port
- Low On Capacitance: 18pF Typical
- Low On Resistance: 10Ω Maximum
- Low Power Consumption: 1uA
Maximum 10uA Maximum I_{CC} over an Expanded Voltage Range (Vin=2.7V, Vcc=4.3V)
- Wide -3dB Bandwidth: >300MHz
- Wide Supply Range: 1.65~5.5V
- Packaged: 6-Lead SC70 and SOT23
- 8kV HBM ESD Rating, 2kV CDM ESD Rating

Applications

- Cell Phones
- PDAs
- Portable Instrumentation
- Battery Powered Communications
- Computer Peripherals

Descriptions

The DIO3157E is an enhanced single-pole double-throw (SPDT) CMOS analog switch. It features power ON/OFF protection on common ports effectively protecting device against external signal perturbation. It also offers excellent -3db bandwidth and lower ON resistance, which can be used as analog switch in multiple applications.

DIO3157E operates under wide Vcc supply from 1.65V to 5.5V, consuming very low quiescent current even when the voltage of S pin is lower than V_{CC} supply. This new feature services the mobile handset applications very well allowing for the direct interface with baseband processor general purpose I/Os with no need of level translator.

Ordering Information

Order Part Number	Top Marking		T _A	Package	
DIO3157ESC6	YW(X)Z	RoHS/Green	-40 to +85°C	SC70-6	Tape & Reel, 3000
DIO3157EST6	YW(X)Z	RoHS/Green	-40 to +85°C	SOT23-6	Tape & Reel, 3000

Pin Assignment

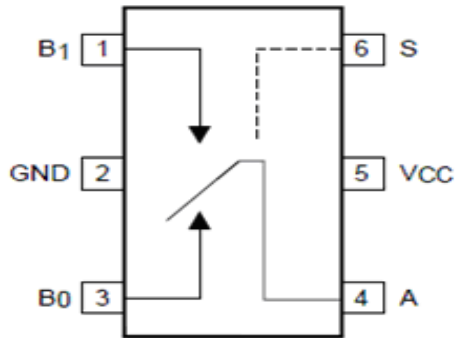

Figure 1 Top View

Pin Descriptions

Pin Name	Description
B1	Data Port
GND	Ground
B0	Data Port, Normally Connect to A
A	Common Port
Vcc	Power Supply
S	Control Port

Truth Table

S	Function
1	B1 Connected to A
0	B0 Connected to A

Absolute Maximum Ratings

Stresses beyond those listed under "Absolute Maximum Rating" may cause permanent damage to the device. These are stress ratings only and functional operation of the device at these or any other condition beyond those indicated in the operational sections of the specifications is not implied. Exposure to absolute maximum rating conditions for extended periods may affect device reliability.

Symbol	Parameter	Min.	Max.	Unit
V_{CC}	Supply Voltage	-0.5	+6	V
V_S	DC Switch Voltage	-0.5	$V_{CC}+0.5$	V
V_{IN}	DC Input Voltage	-0.5	+6	V
I_{IK}	DC Input Diode Current	-50		mA
I_{SW}	Switch Current		100	mA
I_{SWpeak}	Peak Switch Current (Pulse at 1ms duration, <10% Duty Cycle)		200	mA
P_D	Power Dissipation at 85°C		180	mW
T_{STG}	Storage Temperature Range	-65	150	°C
T_j	Junction Temperature		150	°C
T_L	Lead Temperature Range		260	°C
ESD	HBM, JEDEC : JESD22-A114		8	kV
	CDM, JEDEC : JESD22-C101		2	

Recommend Operating Conditions

The Recommended Operating Conditions table defines the conditions for actual device operation to ensure optimal performance to the datasheet specifications. DIOO does not recommend exceeding them or designing to Absolute Maximum Ratings.

Symbol	Parameter	Min.	Max.	Unit
V_{CC}	Supply Voltage	1.65	5.5	V
V_{CNTRL}	Control Input Voltage	1.65	5.5	V
V_{SW}	Switch Input Voltage	1.65	5.5	V
T_A	Operating Temperature	-40	85	°C
Θ_{JA}	Thermal Resistance in Still Air		350	°C /W

DC Electrical Characteristics

All typical value are at $T_A = 25^\circ\text{C}$ unless otherwise specified.

Symbol	Parameter	Conditions	Vcc(V)	Min.	Typ.	Max.	Unit
V_{IH}	Input voltage high	$T_A = -40^\circ\text{C}$ to 85°C	1.8--2.7	1.3			V
			2.7--3.6	1.7			
			4.5--5.5	2.2			
V_{IL}	Input voltage low	$T_A = -40^\circ\text{C}$ to 85°C	1.8--2.7			0.6	V
			2.7--3.6			0.7	
			4.5--5.5			1.0	
I_{IN}	Control input leakage	$T_A = -40^\circ\text{C}$ to 85°C $V_{in} = 0\text{V}$ to V_{cc}	2.7--3.6	-1		1	μA
			4.5--5.5	-1		1	
I_{OFF}	Power off leakage current	$A=1\text{V}$, 4.5V, B0 or B1 =4.5, 1V	5.5	-2		2	nA
		$T_A=-40^\circ\text{C}$ to 85°C , $A=1\text{V}$, 4.5V, B0 or B1 =4.5, 1V	5.5	-20		20	
$I_{A(ON)}$	On leakage current of Poart A	$A=1\text{V}$, 4.5V, B0 or B1 =4.5, 1V, 4.5V or Floating	5.5	-4		4	nA
		$T_A = -40^\circ\text{C}$ to 85°C $A=1\text{V}$, 4.5V, B0 or B1 =4.5, 1V, 4.5V or Floating	5.5	-40		40	
R_{ON}	Switch on Resistance (See figure 2.)	$I_{out} = 30\text{mA}$, B0 or B1 = 1.5V	2.7		10		Ω
		$I_{out} = 30\text{mA}$, B0 or B1 = 3.5V	4.5		4		
		$T_A = -40^\circ\text{C}$ to 85°C , $I_{out} = 30\text{mA}$, B0 or B1 = 1.5V	2.7			12	
		$T_A = -40^\circ\text{C}$ to 85°C , $I_{out} = 30\text{mA}$, B0 or B1 = 3.5V	4.5			6	
ΔR_{ON}	On Resistance Matching between Channels	$I_{out} = 30\text{mA}$, B0 or B1 = 1.5V	4.5			0.2	Ω
		$T_A = -40^\circ\text{C}$ to 85°C , $I_{out} = 30\text{mA}$, B0 or B1 = 1.5V	4.5			0.4	
$R_{FLT(ON)}$	On Resistance Flatness	$I_{out} = 30\text{mA}$, B0 or B1 = 0V, 0.75V, 1.5V	2.7			5	Ω
		$I_{out} = 30\text{mA}$, B0 or B1 = 0V, 1V, 2V	4.5			1	
		$T_A = -40^\circ\text{C}$ to 85°C $I_{out} = 30\text{mA}$, B0 or B1 = 0V, 0.75V, 1.5V	2.7			5	
		$T_A = -40^\circ\text{C}$ to 85°C $I_{out} = 30\text{mA}$, B0 or B1 = 0V, 1V, 2V	4.5			1	
I_{CC}	Quiescent supply current	$V_{in} = 0\text{V}$ or V_{cc} , $I_{out} = 0$	3.6		0.1		μA
			5.5		0.1		
		$T_A = -40^\circ\text{C}$ to 85°C $V_{in} = 0\text{V}$ or V_{cc} , $I_{out} = 0$	3.6			1	
			5.5			1	
ΔI_{CC}	Icrease in I_{cc} per Input	One input at 2.7V, others at V_{cc} or GND	4.3		0.2	5	μA
		$T_A = -40^\circ\text{C}$ to 85°C , One input at 2.7V, others at V_{cc} or GND	4.3			10	

AC Electrical Characteristics

All typical value are for $V_{CC} = 3.3V$ at $T_A = 25^\circ C$ unless otherwise specified.

Symbol	Parameter	Conditions	Vcc(V)	Min	Typ	Max	Unit
T _{ON}	Turn-On Time (See figure 3.)	B0 or B1 = 1.5V, R _L = 50Ω, C _L = 35pF	2.7--3.6			35	ns
		B0 or B1 = 1.5V, R _L = 50Ω, C _L = 35pF	4.5--5.5			25	
T _{OFF}	Turn-Off Time (See figure 3.)	B0 or B1 = 1.5V, R _L = 50Ω, C _L = 35pF	2.7--3.6			30	ns
		B0 or B1 = 1.5V, R _L = 50Ω, C _L = 35pF	4.5--5.5			20	
T _{bbm}	Break-Before -Make Time (See figure 4.)	T _A = -40°C to 85°C	2.7--3.6			6.5	ns
			4.5--5.5			3.5	
Q	Charge Injection (See figure 5.)	C _L = 1nF, VGE = 0V, RGEN = 0Ω	2.7--3.6		10		pC
			4.5--5.5		20		
OIRR	Off Isolation (See figure 6.)	F = 1MHz, R _L = 50Ω	2.7--3.6		-77		dB
			4.5--5.5		-80		
Xtalk	Crosstalk (See figure 7.)	F = 1MHz, R _L = 50Ω	2.7--3.6		-77		dB
			4.5--5.5		-80		
BW	-3dB bandwidth (See figure 8.)	R _L = 50Ω	2.7--3.6		350		MHz
			4.5--5.5		350		
THD	Total Harmon Distortion (See figure 9.)	R _L = 600Ω, V _{in} = 0.5V f = 20Hz to 20KHz	2.7--3.6		0.02		%
			4.5--5.5		0.02		

Capacitance

Symbol	Parameter	Conditions	Min	Typ	Max	Unit
C _{IN}	Control Pin input Capacitance	V _{CC} =0V		1		pF
C _{OFF}	B port Off Capacitance (See figure 10.)	V _{CC} =4.5V, f = 1MHz		5		
C _{ON}	On Capacitance (See figure 11.)			16		

Test Diagrams

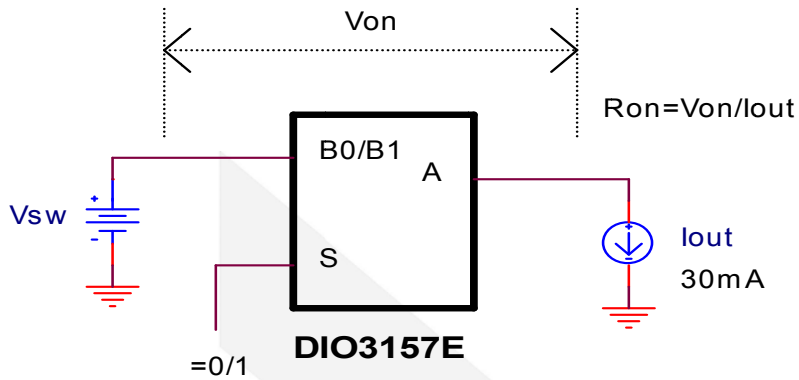

Figure 2. On Resistance

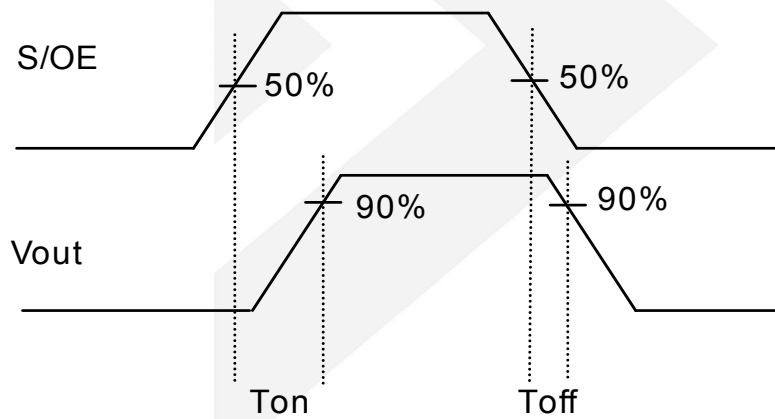

Figure 3. Turn On/Off Time

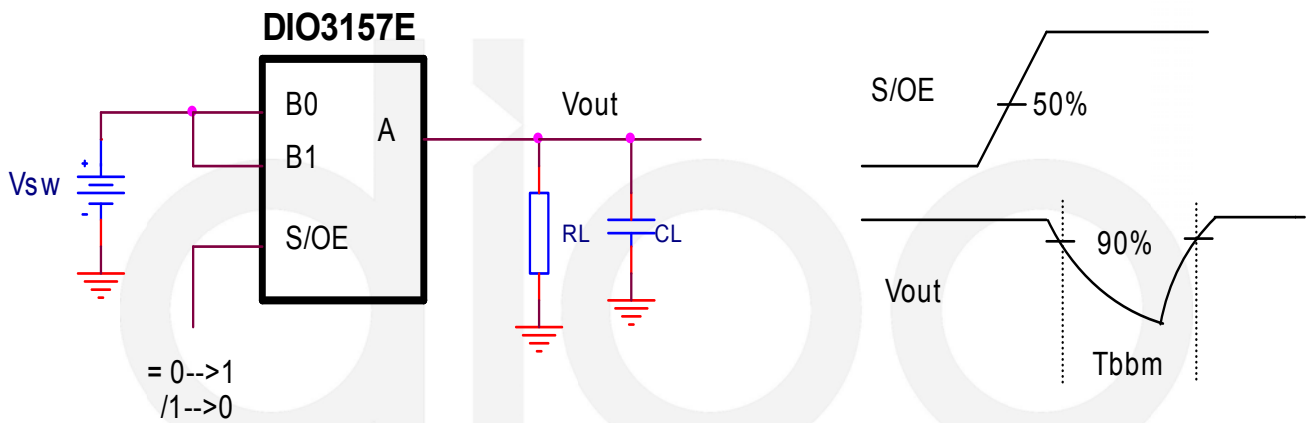

Figure 4. Break-Before-Make Time

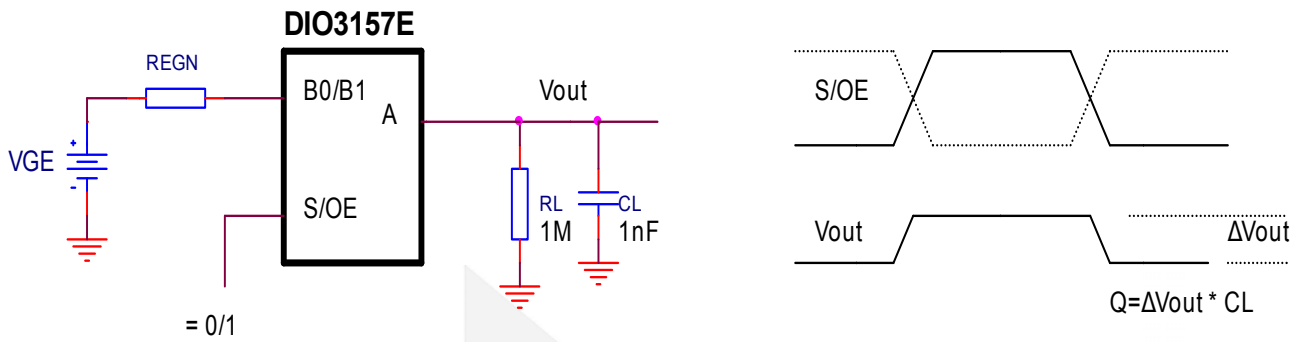

Figure 5. Charge Injection

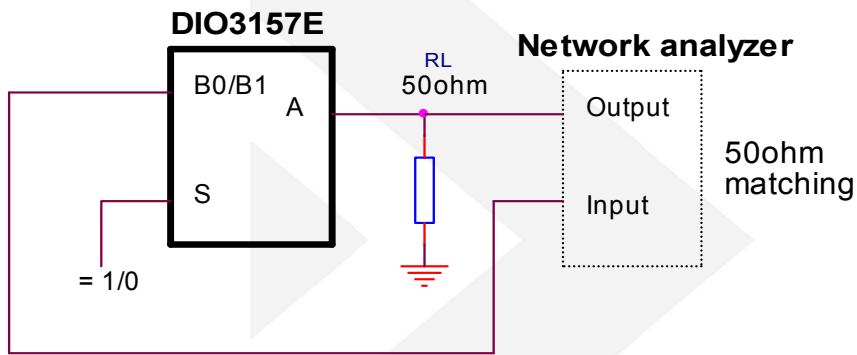

Figure 6. Channel Off Isolation

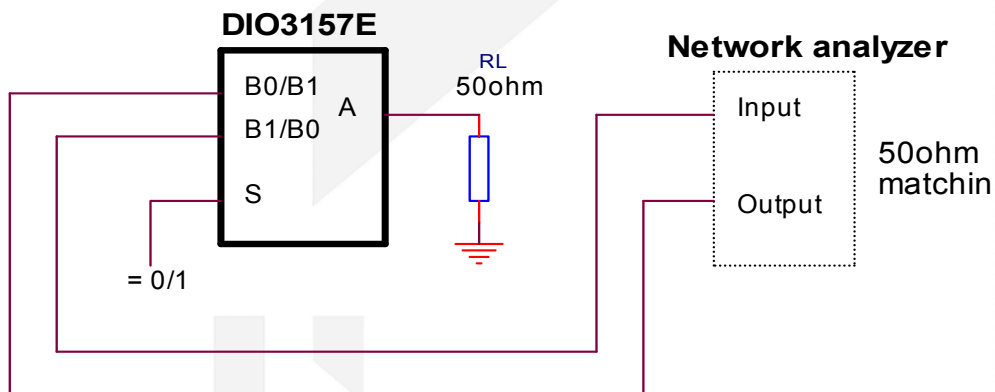

Figure 7. Channel to Channel Crosstalk

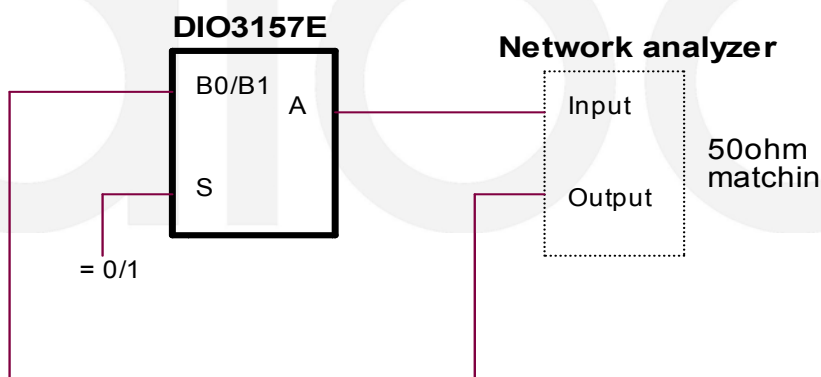

Figure 8. -3dB Bandwidth

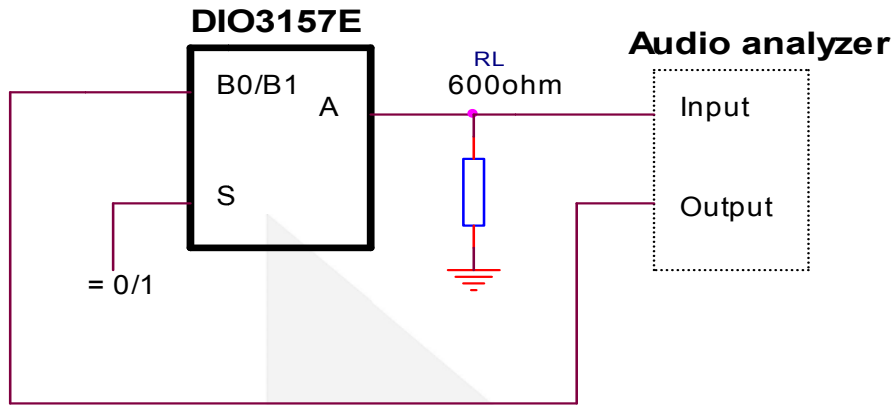

Figure 9. Total Harmon Distortion

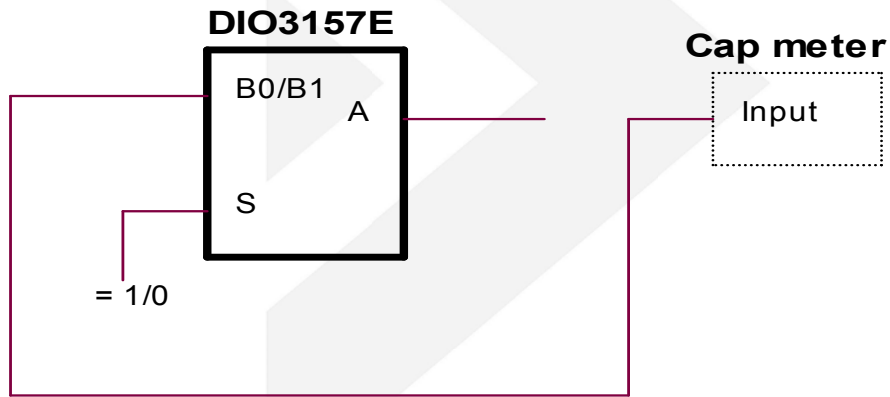

Figure 10. Channel Off Capacitance

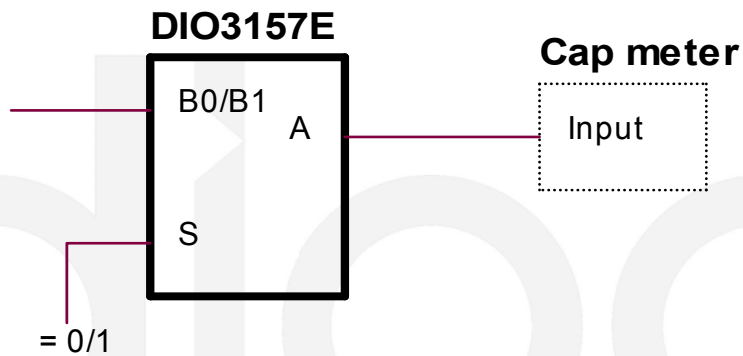
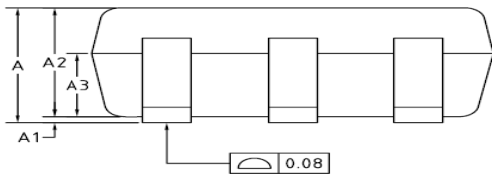
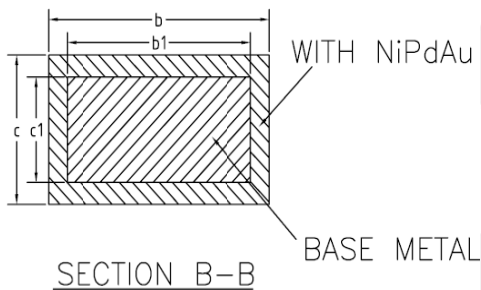
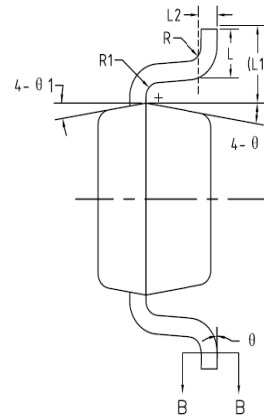
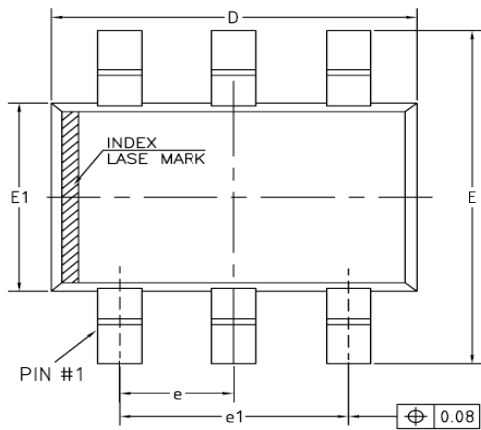
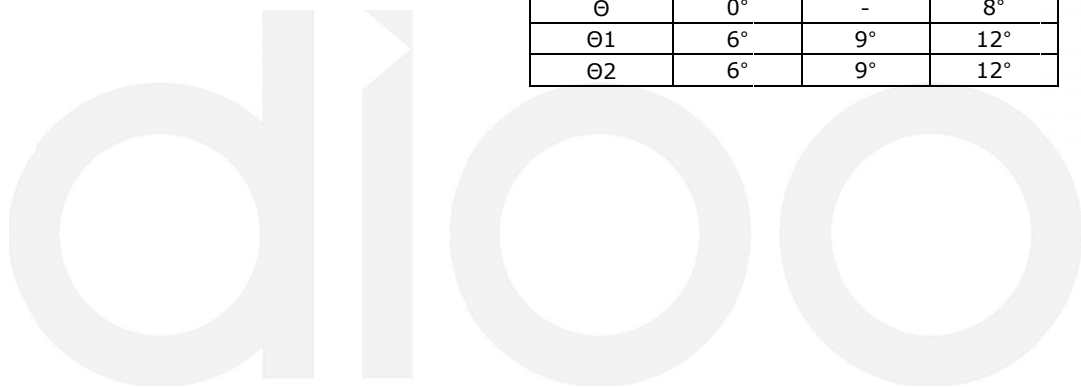

Figure 11. Channel On Capacitance

Physical Dimensions: SC70-6



COMMON DIMENSIONS (UNITS OF MEASURE=MILLIMETER)			
Symbol	MIN	NOM	MAX
A	0.85	-	1.05
A1	0	-	0.10
A2	0.80	0.90	1.00
A3	0.47	0.52	0.57
b	0.22	-	0.29
b1	0.22	0.25	0.28
c	0.115	-	0.15
c1	0.115	0.13	0.14
D	2.02	2.07	2.12
E	2.20	2.30	2.40
E1	1.25	1.30	1.35
e	0.65BSC		
e1	1.30BSC		
L	0.28	0.33	0.38
L1	0.50REF		
L2	0.15BSC		
R	0.10	-	-
R1	0.10	-	0.25
θ	0°	-	8°
θ1	6°	9°	12°
θ2	6°	9°	12°



Physical Dimensions: SOT-23-6

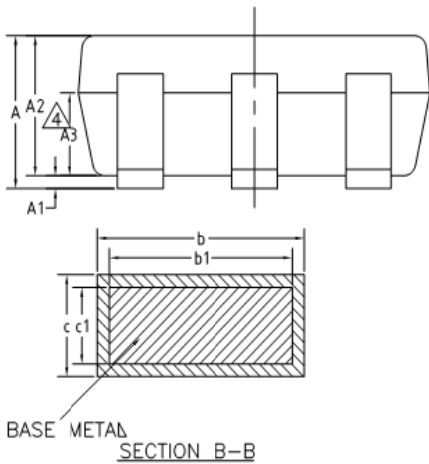
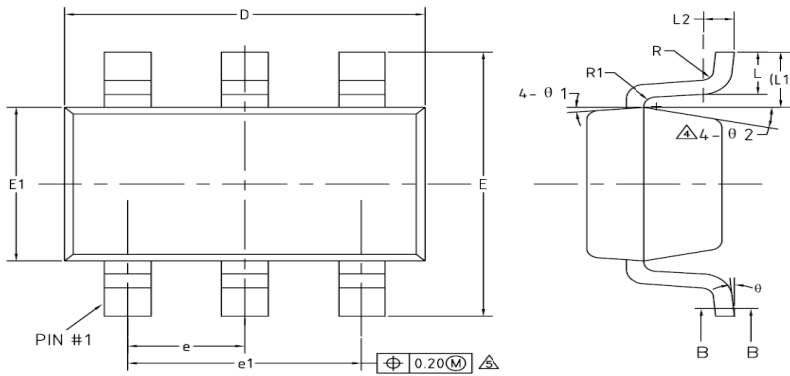

COMMON DIMENSIONS (UNITS OF MEASURE=MILLIMETER)			
Symbol	MIN	NOM	MAX
A	-	-	1.25
A1	0	-	0.15
A2	1.00	1.10	1.20
A3	0.60	0.65	0.70
b	0.36	-	0.50
b1	0.36	0.38	0.45
c	0.14	-	0.20
c1	0.14	0.15	0.16
D	2.826	2.926	3.026
E	2.60	2.80	3.00
E1	1.526	1.626	1.726
e	0.90	0.95	1.00
e1	1.80	1.90	2.00
L	0.35	0.45	0.60
L1	0.59REF		
L2	0.25BSC		
R	0.10	-	-
R1	0.10	-	0.25
theta	0°	-	8°
theta 1	3°	5°	7°
theta 2	6°	-	14°

CONTACT US

Dioo is a professional design and sales corporation for high-quality and performance analog semiconductors. The company focuses on industry markets, such as, cell phone, handheld products, laptop, and medical equipments and so on. Dioo's product families include analog signal processing and amplifying, LED drivers and charger IC. Go to <http://www.dioo.com> for a complete list of Dioo product families.

For additional product information, or full datasheet, please contact with our Sales Department or Representatives.



X-ON Electronics

Largest Supplier of Electrical and Electronic Components

Click to view similar products for [Analogue Switch ICs category](#):

Click to view products by [Dioo manufacturer](#):

Other Similar products are found below :

[FSA3051TMX](#) [NLVAS4599DTT1G](#) [MAX4992EVB+T](#) [MAX4684ETB+T](#) [BCM6522IPBG](#) [BCM65300IFSBG](#) [MAX14764ETA+T](#)
[TMUX1113RSVR](#) [TMUX1112RSVR](#) [ADG1436TRUZ-EP](#) [BL4684C](#) [PE423422A](#) [PE42359SCAA](#) [PE42540F](#) [RS550YUCM12](#)
[ADGS1414DBCCZ](#) [ADG658YRUZ-REEL7](#) [RS2117YUTQK10](#) [RS2118YUTQK10](#) [RS2227XUTQK10](#) [SP2526A-1EN-L/TR](#) [FSA4157P6X](#)
[BA7603F-E2](#) [MAX4702EUE+](#) [MAX4617CUE+](#) [MAX4599EUT+T](#) [MAX4066ESD+](#) [MAX4052ACSE+](#) [MAX396CAI+](#) [MAX391CPE+](#)
[MAX4730EXT+T](#) [MAX314CPE+](#) [MAX4051AEEE+](#) [BU4066BCFV-E2](#) [MAX313CPE+](#) [BU4S66G2-TR](#) [TS3A4751PWR](#)
[NCN1154MUTAG](#) [DG444DY-E3](#) [NLAS4157DFT2G](#) [NLAS4599DFT2G](#) [NLAS7242MUTBG](#) [NLASB3157DFT2G](#) [NLAST4599DFT2G](#)
[NLAST4599DTT1G](#) [DG403DY-T1-E3](#) [MAX4714EXTT](#) [MAX392CPE](#) [BGSX22G2A10E6327XTSA1](#) [ADG1611BRUZ-REEL7](#)