

DIO32020

USB2.0 High-Speed and Audio/USB/UART Switch with Negative Swing Capacity

Features

- Low Ron Audio/USB analog switch
- Low USB Con: 7pF
- Negative Signal Swing Capable
- Low Audio Distortion
- USB Switch -3dB Bandwidth: 1100MHz
- High Crosstalk and Off-isolation
- Voltage Supply Operation: 2.7 to 5.5V
- Three Green Packages: DQFN-10, QFN-10, MSOP-10

Applications

- Cell-Phone/PDA
- MP3/MP4/PMP
- Portable Instrumentation
- Battery Powered Communications
- Computer Peripherals

Descriptions

The DIO32020 is dual SPDT (Single Pole/Double Throw) switch which combines low distortion audio/USB/UART and USB2.0 high-speed data signal switching in the same low voltage device. This architecture is designed to allow negative signal passing as low as 3V below ground. When a voltage is detected on V_{BUS} , DIO32020 will immediately switch to USB mode. Due to ultra low capacitance design, the audio channels (pin 3 and pin 4 input/outputs) are able to not only switch audio signal but also high speed USB signal or low voltage UART signal as well.

DIO32020 provides packages with Green or RoHS tiny 10L packages, and operates over a temperature range of -40°C to 85°C .

Block Diagram

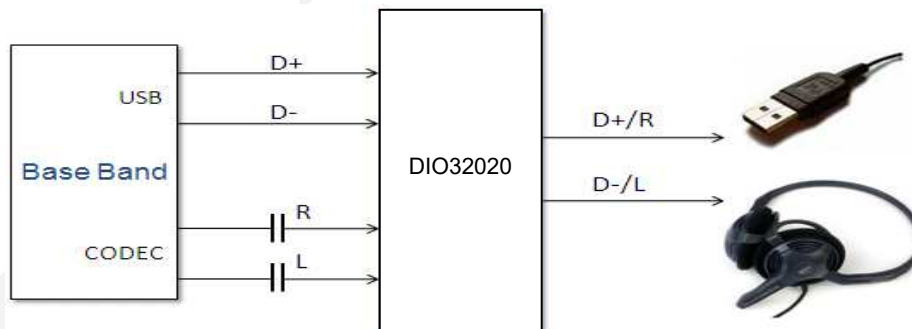

Ordering Information

Order Part Number	Top Marking		T_A	Package	
DIO32020LP10	YW0A	Green	-40 to 85°C	DQFN-10	Tape & Reel, 3000
DIO32020QN10	YW0A	Green	-40 to 85°C	QFN-10	Tape & Reel, 3000
DIO32020MP10	D32020	Green	-40 to 85°C	MSOP-10	Tape & Reel, 3000

Pin Assignment

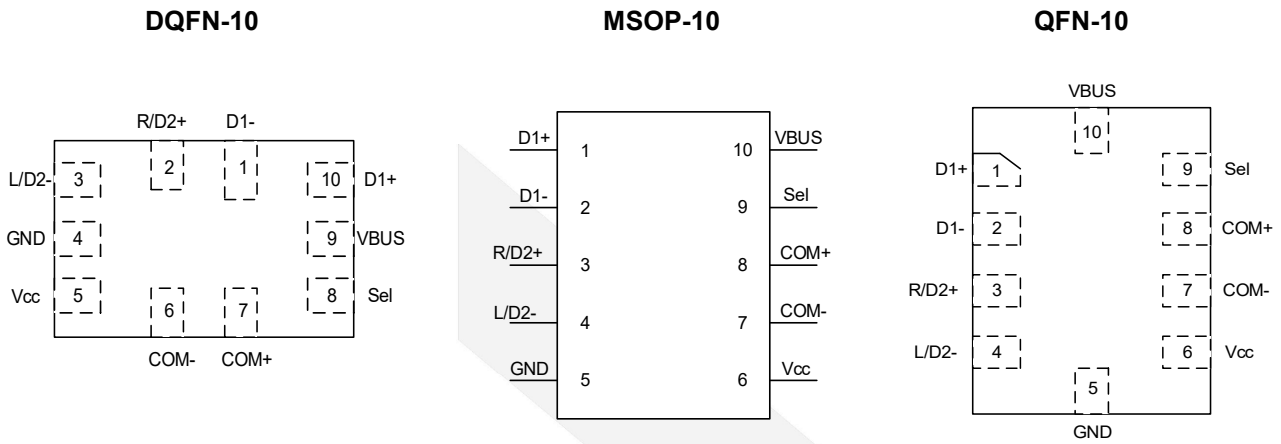

Figure 1 Top View

Pin Descriptions

Pin Name	Direction	Description
D1+, D1-	I/O	Differential USB Data Input 1
R/D2+, L/D2-	I/O	Audio R/L or differential USB data input 2
V _{Bus}	I	Switch Select
COM+/COM-	I/O	Data/Audio Common Port
Sel	I	Control Input
Vcc/ GND	P	Power

Truth Table

Sel	V _{Bus}	L/D2-, R/D2+	D1+, D1-
Low	Low	ON	OFF
Low	High	OFF	ON
High	X	ON	OFF



DIO32020

USB2.0 High-Speed and Audio Switch with Negative Swing Capacity

Absolute Maximum Ratings

Stresses beyond those listed under "Absolute Maximum Rating" may cause permanent damage to the device. These are stress ratings only and functional operation of the device at these or any other condition beyond those indicated in the operational sections of the specifications is not implied. Exposure to absolute maximum rating conditions for extended periods may affect device reliability.

Symbol	Parameter	Rating	Unit	
V _{CC}	Supply Voltage	-0.5 to 6.5	V	
V _{BUS}	V _{BUS} Control Input Voltage	-0.5 to 6.5	V	
V _{IN}	A _{SEL} Control Input Voltage	-0.5 to 6.5	V	
V _{SW}	USB Path Analog Signal Voltage	-0.5 to 6.5	V	
	Audio Path Analog Signal Voltage	-3.5 to 6.5		
	Storage Temperature	-65 to 150	°C	
I _{IN}	A _{SEL} Control Input Current	5	μA	
	V _{BUS} Control Input Current	5		
I _{SW_CON}	Analog Signal Continuous Current	±100	mA	
I _{SW_PK}	Analog Signal Peak Current	±500	mA	
ESD	HBM, JEDEC: JESD22-A114	I/O to GND	5	kV
		Others	8	

Recommend Operating Conditions

The Recommended Operating Conditions table defines the conditions for actual device operation. Recommended Operating conditions are specified to ensure optimal performance to the datasheet specifications. DIOO does not Recommend exceeding them or designing to Absolute Maximum Ratings.

Symbol	Parameter	Rating	Unit
V _{CC}	Supply Voltage	2.7 to 5.5	V
V _{IN}	V _{BUS} Control Input Voltage	0 to 5.5	V
	A _{SEL} Control Input Voltage	0 to V _{CC}	
V _{SW}	USB to COM Analog Signal Voltage	0 to V _{CC}	V
	Audio to COM Analog Signal Voltage	-3 to V _{CC}	
T _A	Operating Temperature Range	-40 to 85	°C



DIO32020

USB2.0 High-Speed and Audio Switch with Negative Swing Capacity

DC Electrical Characteristics

All typical value are at $T_A = 25^\circ\text{C}$ unless otherwise specified.

Symbol	Parameter	Conditions	Min.	Typ.	Max.	Unit
CONTROL INPUT ($T_A=25^\circ\text{C}$, $V_{CC}=3.3\text{V}$)						
V_{IH}	A_{SEL} Control Input High Voltage	$V_{CC}=2.7-4.2\text{V}$	1.3			V
V_{IL}	A_{SEL} Control Input Low Voltage	$V_{CC}=2.7-4.2\text{V}$			0.5	V
I_{IN}	A_{SEL} Control Input Leakage Current	$0 \leq V_{SW} \leq V_{CC}$		1	2	μA
V_{IH}	V_{BUS} Control Input High Voltage	$V_{CC}=2.7-4.2\text{V}$	1.3			V
V_{IL}	V_{BUS} Control Input Low Voltage	$V_{CC}=2.7-4.2\text{V}$			0.5	V
I_{IN}	V_{BUS} Control Input Leakage Current	$0 \leq V_{SW} \leq V_{CC}$		1	2	μA
R_{VBUS_PD}	V_{BUS_CTRL} Pull down Resistance	$I_{ON}=10\text{mA}$		4000		$\text{k}\Omega$
SUPPLY CURRENT AND LEAKAGE ($T_A=25^\circ\text{C}$, $V_{CC}=3.3\text{V}$)						
I_{OZ-USB}	Off Leakage Current of port DN/DP	DN/DP=0V to 4.2V, R, L, COM+, COM- float	-1		1	μA
$I_{OZ-AUDIO}$	Off Leakage Current of port R/L	R/L=-3V to 3V, DN, DP, COM+, COM- float	-1		1	μA
I_{ON-USB}	On Leakage Current of USB Switch	COM+/COM- =0V to 4.2V, R, L, DN, DP float	-1		1	μA
$I_{ON-AUDIO}$	On Leakage Current of AUDIO Switch	COM+/COM- =-3V to 3V, R, L, DN, DP float	-1		1	μA
I_{off}	Power off leakage	$V_{CC}=0\text{V}$	-1		1	μA
I_{CC}	Quiescent Supply			18	35	μA
USB SWITCHES (D+, D-) ($T_A=25^\circ\text{C}$, $V_{CC}=3.3\text{V}$)						
R_{ON}	On Resistance	$I_{ON}=10\text{mA}$, $V_{SW}=0\text{V}$ to V_{CC}		3.8		Ω
R_{FLATE}	On Resistance Flatness	$I_{ON}=10\text{mA}$, $V_{SW}=0\text{V}$ to V_{CC}		15		$\text{m}\Omega$
ΔR_{ON}	On Resistance Matching	$I_{ON}=10\text{mA}$, $V_{SW}=0\text{V}$ to V_{CC}		100		$\text{m}\Omega$
AUDIO SWITCHES (R, L) ($T_A=25^\circ\text{C}$, $V_{CC}=3.3\text{V}$)						
R_{ON}	On Resistance	$I_{ON}=100\text{mA}$, $V_{SW}=-3$ to 3V		0.8		Ω
R_{FLATE}	On Resistance Flatness	$I_{ON}=100\text{mA}$, $V_{SW}=-3$ to 3V		2		$\text{m}\Omega$
ΔR_{ON}	On Resistance Matching	$I_{ON}=100\text{mA}$, $V_{SW}=-3$ to 3V		50		$\text{m}\Omega$



DIO32020

USB2.0 High-Speed and Audio Switch with Negative Swing Capacity

Electrical Characteristics (Continued)

All typical value are at $T_A=25^\circ\text{C}$ unless otherwise specified.

Symbol	Parameter	Conditions	Min.	Typ.	Max.	Unit
AC Parameter ($T_A=25^\circ\text{C}$, $V_{CC}=3.3\text{V}$, $R_L=50\Omega$, $C_L=5\text{pF}$, unless otherwise specified)						
t_{ON}	USB Turn-on Time	DP=DN=1.5V, $R_L=50\Omega$, $C_L=35\text{pF}$		32		μs
	Audio Turn-on Time	L=R=1.5V, $R_L=50\Omega$, $C_L=35\text{pF}$		32		μs
t_{OFF}	USB Turn-off Time	DP=DN=1.5V, $R_L=50\Omega$, $C_L=35\text{pF}$		100		ns
	Audio Turn-off Time	L=R=1.5V, $R_L=50\Omega$, $C_L=35\text{pF}$		150		ns
T_{BBM}	Break Before Make Time	Audio off to USB on		30		μs
		USB off to Audio on		30		μs
BW	-3dB Bandwidth USB Channel	$R_L=50\Omega$, $C_L=5\text{pF}$		1100		MHz
OIRR	USB OFF-Isolation	$V_{SW}=1V_{RMS}$, $R_L=50\Omega$, $f=240\text{MHz}$		-23		dB
	Audio OFF-Isolation	$V_{SW}=1V_{RMS}$, $R_L=50\Omega$, $f=1\text{kHz}$		-110		dB
X_{TALK}	USB Crosstalk	$R_L=50\Omega$, $f=240\text{MHz}$		-45		dB
	Audio Crosstalk	$R_L=50\Omega$, $f=1\text{kHz}$		-80		dB
THD+N	Total Harmonic Distortion + Noise	$R_L=600\Omega$, $f=1\text{kHz}$, $V_{SW}=2V_{RMS}$, With A-weighted		-110		dB
		$R_L=32\Omega$, $f=1\text{kHz}$, $V_{SW}=1V_{RMS}$, With A-weighted		-100		
		$R_L=16\Omega$, $f=1\text{kHz}$, $V_{SW}=0.5V_{RMS}$, With A-weighted		-100		
PSRR	Power Supply Rejection Ratio	$f=10\text{kHz}$, $R_{COM}=50\Omega$		-75		dB
CAPACITANCE ($T_A=25^\circ\text{C}$, $V_{CC}=3.3\text{V}$, $R_L=50\Omega$, $C_L=5\text{pF}$, $f=1\text{MHz}$, $A_{SEL}=0\text{V}$, unless otherwise specified)						
C_{IN}	A_{SEL} Control Input Capacitance	$V_{CC}=0\text{V}$		2		pF
C_{ON}	USB ON Capacitance	$f=1\text{MHz}$, $V_{BUS}=V_{DD}$, $V_{SEL}=\text{LOW}$, V_{D-} or $V_{D+}=V_{COMX}=0\text{V}$		7		pF



DIO32020

USB2.0 High-Speed and Audio Switch with Negative Swing Capacity

C_{ON}	Audio ON Capacitance	$V_{BUS}=LOW, V_{SEL}=LOW$	7	pF
C_{OFF}	USB OFF Capacitance	$V_{BUS}=VDD, V_{SEL}=LOW$	3	pF
C_{OFF}	Audio OFF Capacitance	$V_{BUS}=LOW, V_{SEL}=LOW$	4	pF

Typical Performance Characteristics

$T_A=25^{\circ}C, V_{CC}=3.3V$, unless otherwise specified.

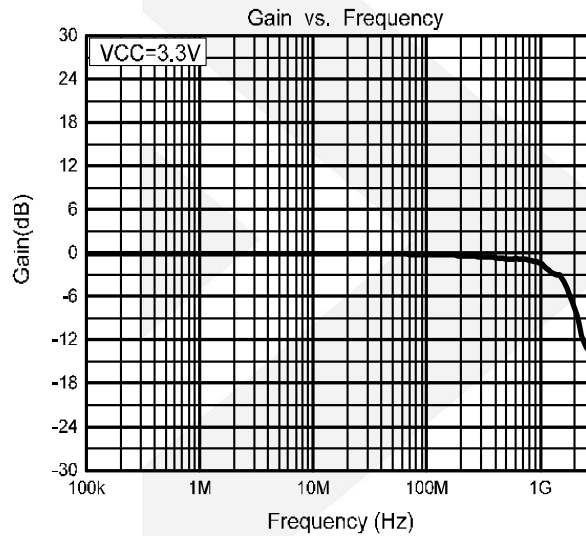

DIO32020 USB 2.0 high speed (480Mbps) eye pattern

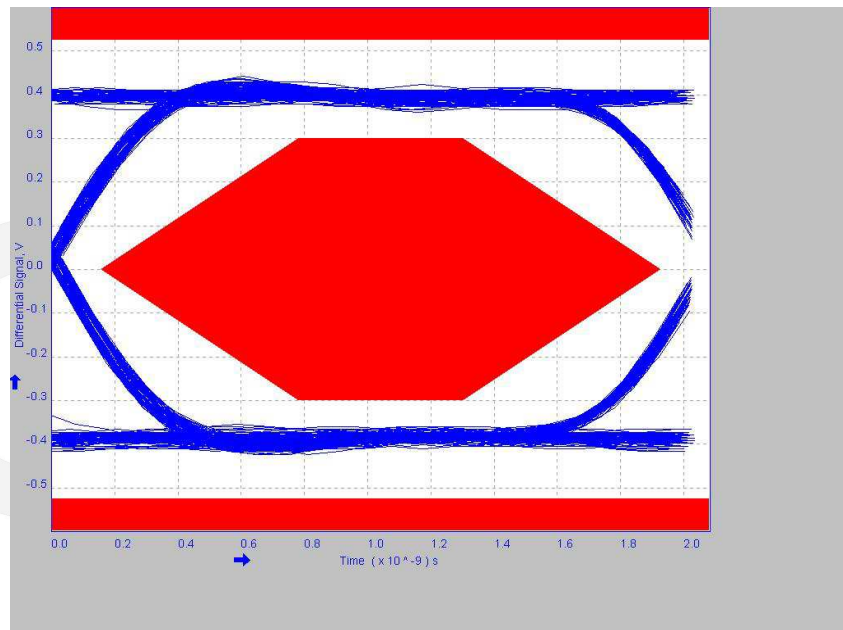

TIME SCALE (0.2ns/DIV)

Figure 2 Eye Pattern: 480Mbps with USB switch In signal path

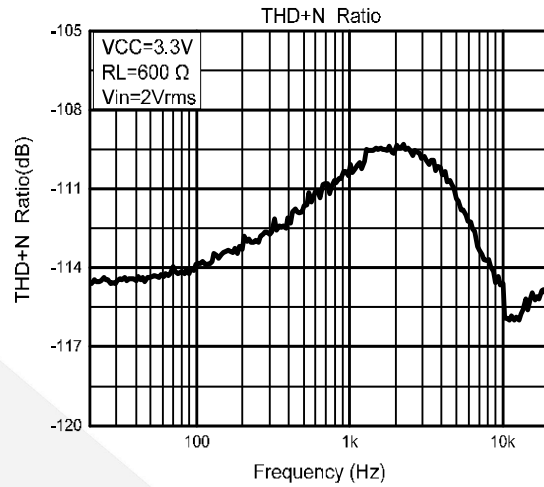
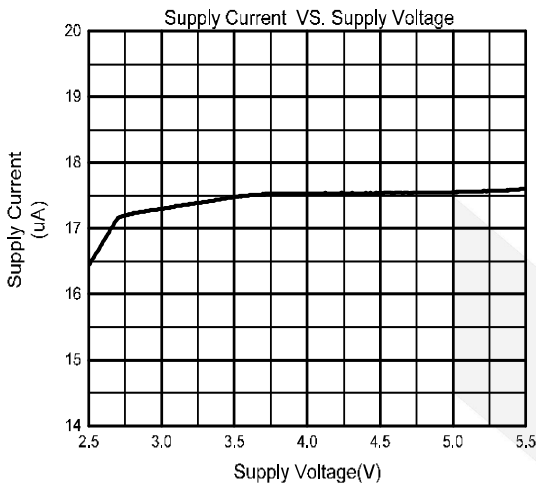

Applications Design Guide

DIO32020 is used in applications where the slim and thin smart phone designs are expected. By sharing the USB connector between USB2.0 data lines and audio headphone outputs, the designers can eliminate the using of bulky headphone jacks. Meanwhile, using the mini-USB connectors as audio outputs allows the end users to reduce the cost to buy too many different types of cell phone accessories.

DIO32020 unique architectures allow the part to allow the part to have constant Ron, Ron (flatness) and THD performance independent of Vcc supply value. So in some applications such as mobile cell phone designs, if the designers want to achieve the lowest standby power consumption when the battery is turned OFF, it is highly recommended that DIO32020 be powered by 2.8V, no need of being powered by battery (4.3V) directly. This will help designers to be freed from the complex logic designs to ensure the part will get into sleep mode.

DIO32020's control pins are 1.8V control logic compatible, so the parts can be controlled by baseband processor GPIO directly without worrying about the level shifting issues. Regarding high speed signal integrity, DIO32020 is recommended to be placed as close as possible to the USB controller outputs to reduce the signal reflection under high speed mode (480Mbps). In the meanwhile, the Vcc pin of DIO32020 is required to have decoupling capacitors to reduce the supply ripples.

The below is the DIO32020 USB 2.0 high speed (480Mbps) eye diagram compliance test under near-end mode (most challenging mode).

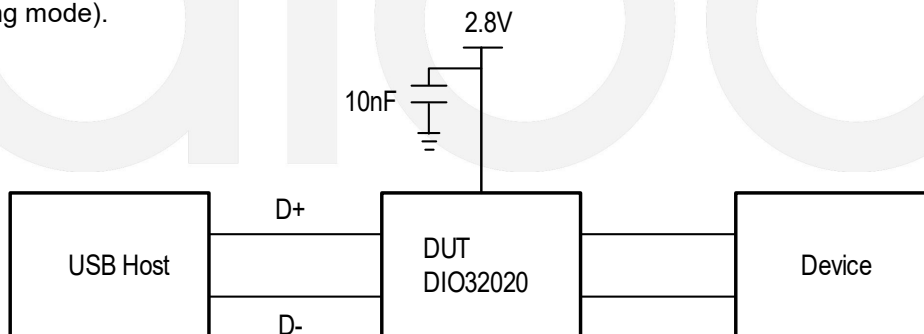

Figure 3 USB2.0 high speed eye diagram test circuit



DIO32020

DIO32020 features not only 100dB total harmonic distortion (THD), but also superior off isolation capability. When DIO32020 is powered under audio mode, audio channel can pass at least -3V negative audio signal with up to 100dB THD performance. Under USB mode or device being powered OFF ($V_{CC}=0$), the negative audio signal on audio ports can be isolated as well to allow flexible design needs.

USB2.0 High-Speed and Audio Switch with Negative Swing Capacity



Physical Dimensions: DQFN-10

PIN 1 DOT
BY MARKING

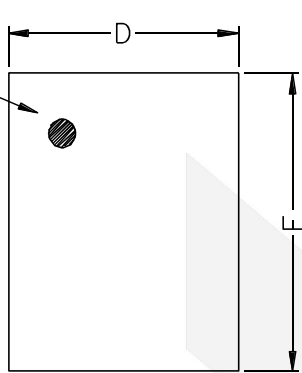

TOP VIEW

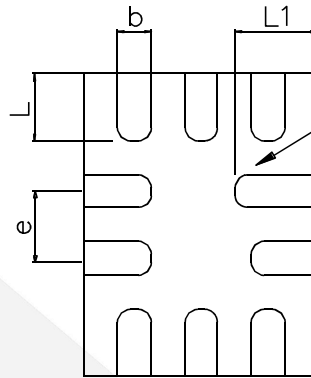

BOTTOM VIEW

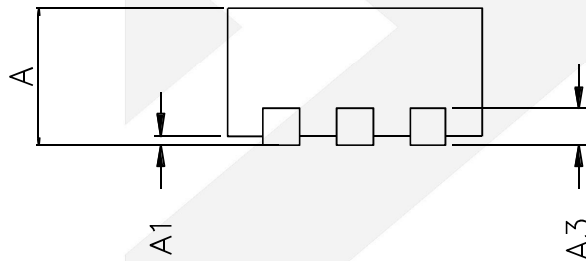

COMMON DIMENSIONS(MM)			
PKG.	UT:ULTRA THIN		
REF.	MIN.	NOM	MAX
A	0.5	0.55	0.6
A1	0		0.05
A3	0.15REF.		
D	1.35	1.4	1.45
E	1.75	1.8	1.85
b	0.15	0.2	0.25
L	0.3	0.4	0.5
L1	0.4	0.5	0.6
e	0.4BSC		

Physical Dimensions: QFN-10

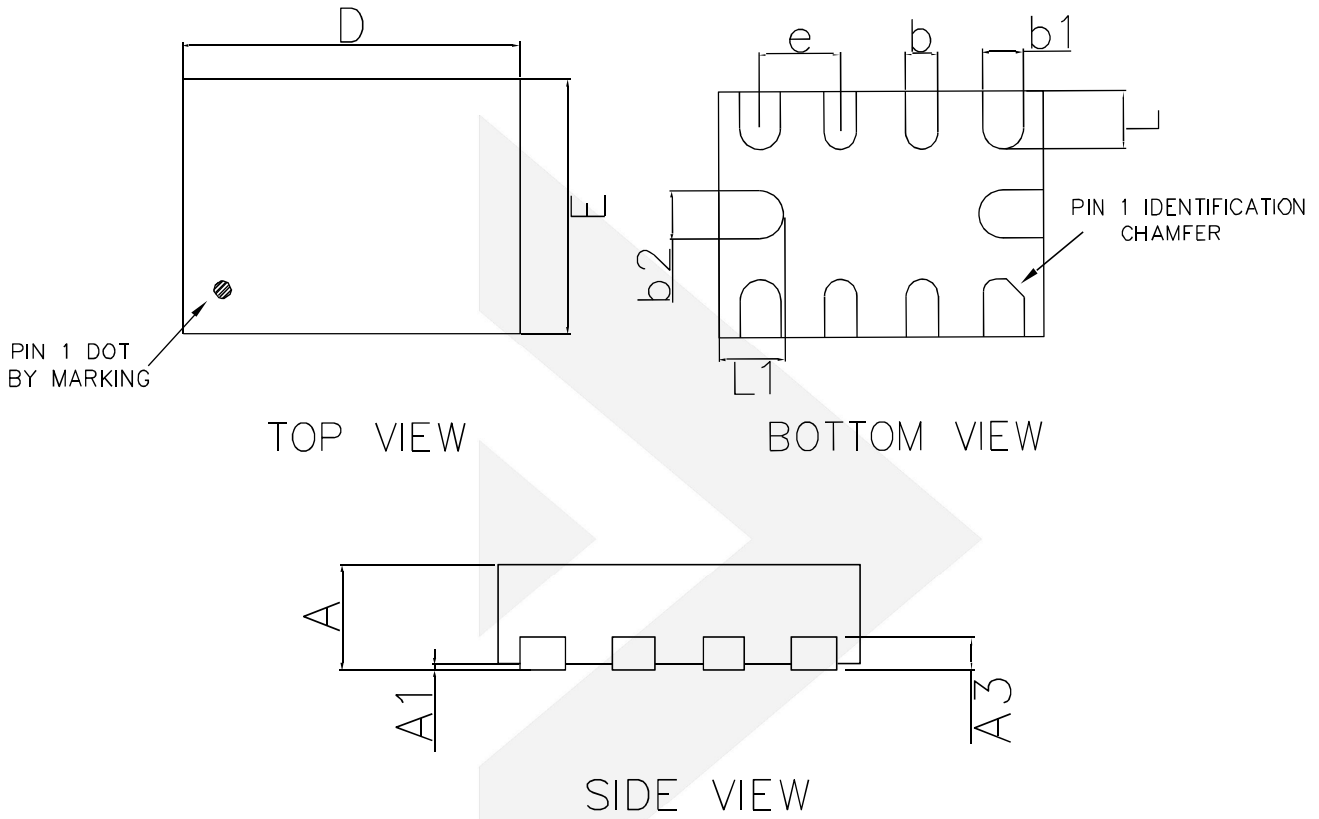

COMMON DIMENSIONS(MM)			
PKG.	UT:ULTRA THIN		
REF.	MIN.	NOM	MAX
A	0.50	0.55	0.60
A1	0.00		0.05
A3	0.15REF.		
D	1.95	2.00	2.05
E	1.45	1.50	1.55
b	0.15	0.20	0.25
b1	0.20	0.25	0.30
b2	0.25	0.30	0.35
L	0.30	0.35	0.40
L1	0.35	0.40	0.45
e	0.50 BSC		

Physical Dimensions: MSOP-10

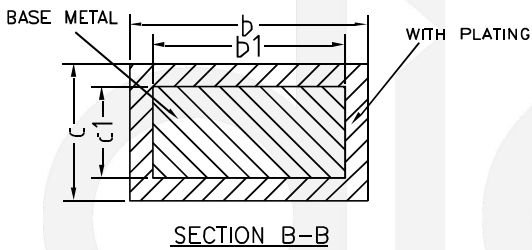
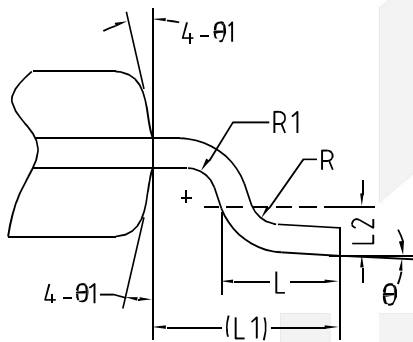
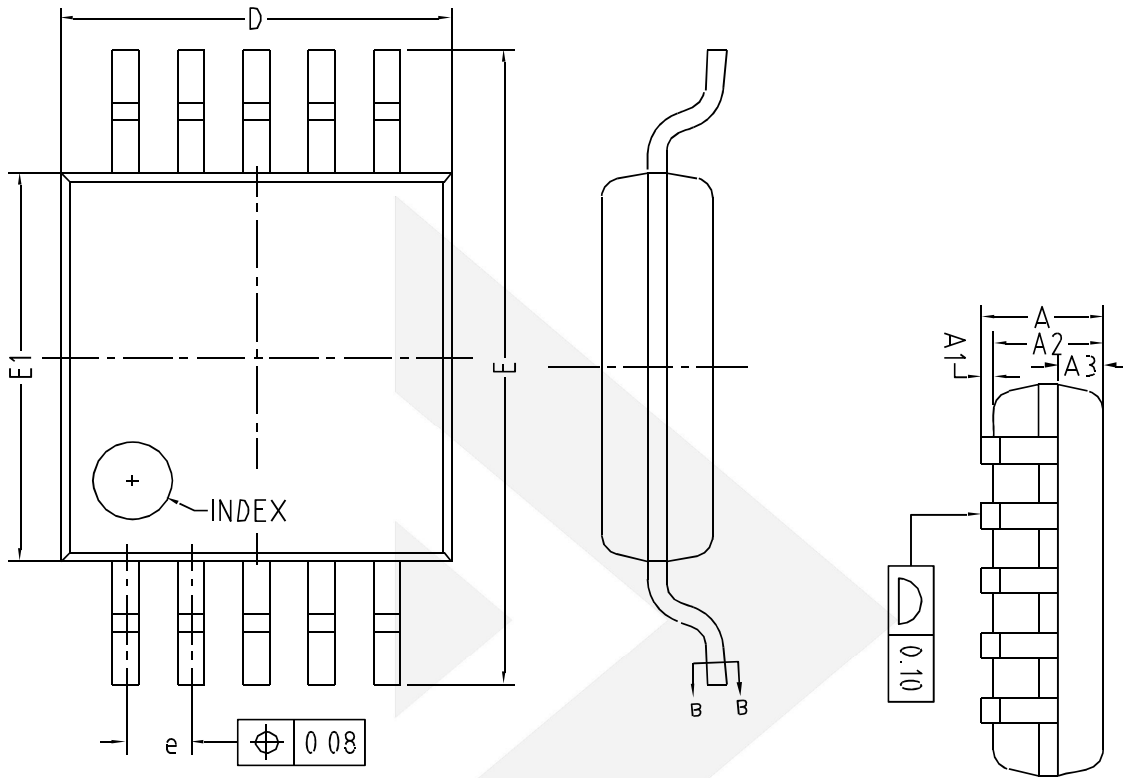

Symbol	Min	Typ	Max
A	-	-	1.10
A1	0	-	0.15
A2	0.75	0.85	0.95
A3	0.25	0.35	0.39
b	0.18	-	0.27
b1	0.17	0.20	0.23
c	0.15	-	0.20
c1	0.14	0.15	0.16
D	2.90	3.00	3.10
E	4.70	4.90	5.10
E1	2.90	3.00	3.10
e	0.40	0.50	0.60
L	0.40	0.60	0.80
L1	0.95REF		
L2	0.25BSC		
R	0.07	-	-
R1	0.07	-	-
θ	0°	-	8°
θ1	9°	12°	15°

CONTACT US

Dioo is a professional design and sales corporation for high-quality and performance analog semiconductors. The company focuses on industry markets, such as, cell phone, handheld products, laptop, and medical equipment and so on. Dioo's product families include analog signal processing and amplifying, LED drivers and charger IC. Go to <http://www.dioo.com> for a complete list of Dioo product families.

For additional product information, or full datasheet, please contact with our Sales Department or Representatives.



X-ON Electronics

Largest Supplier of Electrical and Electronic Components

Click to view similar products for [Analogue Switch ICs category](#):

Click to view products by [Dioo manufacturer](#):

Other Similar products are found below :

[FSA3051TMX](#) [NLVAS4599DTT1G](#) [MAX4992EVB+T](#) [MAX4684ETB+T](#) [BCM6522IPBG](#) [BCM65300IFSBG](#) [MAX14764ETA+T](#)
[TMUX1113RSVR](#) [TMUX1112RSVR](#) [ADG1436TRUZ-EP](#) [BL4684C](#) [PE423422A](#) [PE42359SCAA](#) [PE42540F](#) [RS550YUCM12](#)
[ADGS1414DBCCZ](#) [ADG658YRUZ-REEL7](#) [RS2117YUTQK10](#) [RS2118YUTQK10](#) [RS2227XUTQK10](#) [SP2526A-1EN-L/TR](#) [FSA4157P6X](#)
[BA7603F-E2](#) [MAX4702EUE+](#) [MAX4617CUE+](#) [MAX4599EUT+T](#) [MAX4066ESD+](#) [MAX4052ACSE+](#) [MAX396CAI+](#) [MAX391CPE+](#)
[MAX4730EXT+T](#) [MAX314CPE+](#) [MAX4051AEEE+](#) [BU4066BCFV-E2](#) [MAX313CPE+](#) [BU4S66G2-TR](#) [TS3A4751PWR](#)
[NCN1154MUTAG](#) [DG444DY-E3](#) [NLAS4157DFT2G](#) [NLAS4599DFT2G](#) [NLAS7242MUTBG](#) [NLASB3157DFT2G](#) [NLAST4599DFT2G](#)
[NLAST4599DTT1G](#) [DG403DY-T1-E3](#) [MAX4714EXTT](#) [MAX392CPE](#) [BGSX22G2A10E6327XTSA1](#) [ADG1611BRUZ-REEL7](#)