

## DIO3202A

# USB2.0 High-Speed and Audio/USB/UART Switch with Negative Swing Capacity

### Features

- Low Ron Audio/USB analog switch
- Low USB Con: 5pF
- Negative Signal Swing Capable
- Low Audio Distortion
- USB Switch -3dB Bandwidth: 720MHz
- High Crosstalk and Off-isolation
- Voltage Supply Operation: 2.7 to 5.5V
- Three Green Packaged: DQFN-10, QFN-10, MSOP-10

### Applications

- Cell-Phone/PDA
- MP3/MP4/PMP
- Portable Instrumentation
- Battery Powered Communications
- Computer Peripherals

### Descriptions

The DIO3202A is dual SPDT (Single Pole/Double Throw) switch which combines low distortion audio/USB/UART and USB2.0 high-speed data signal switching in the same low voltage device. This architecture is designed to allow negative signal passing as low as 2V below ground. When a voltage is detected on  $V_{BUS}$ , DIO3202A will immediately switch to USB mode. Due to ultra low capacitance design, the audio channels (pin 3 and pin 4 input/outputs) are able to not only switch audio signal but also high speed USB signal or low voltage UART signal as well.

DIO3202A provides packages with Green or RoHS tiny 10L packages, and operates over a temperature range of  $-40^{\circ}\text{C}$  to  $85^{\circ}\text{C}$ .

### Block Diagram

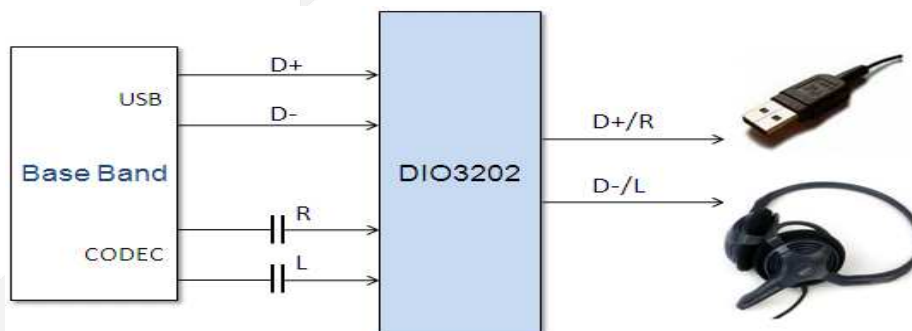

### Ordering Information

Order Part Number	Top Marking		$T_A$	Package	
DIO3202ALP10	YWGF	Green	$-40$ to $+85^{\circ}\text{C}$	DQFN-10	Tape & Reel, 3000
DIO3202AQN10	YWGF	Green	$-40$ to $+85^{\circ}\text{C}$	QFN-10	Tape & Reel, 3000
DIO3202AMP10	D3202A	Green	$-40$ to $+85^{\circ}\text{C}$	MSOP-10	Tape & Reel, 3000



# DIO3202A

USB2.0 High-Speed and Audio Switch with Negative Swing Capacity

## Pin Assignment

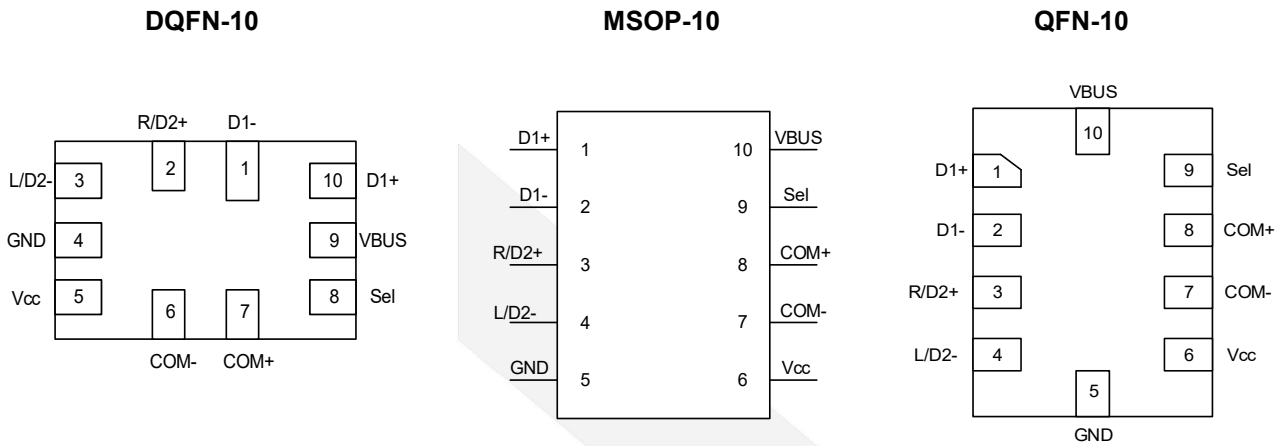

Figure 1 Top View

## Pin Descriptions

Pin Name	Direction	Description
D1+, D1-	I/O	Differential USB Data Input 1
R/D2+, L/D2-	I/O	Audio R/L or differential USB data input 2
V <sub>Bus</sub>	I	Switch Select
COM+/COM-	I/O	Data/Audio Common Port
Sel	I	Control Input
Vcc/ GND	P	Power

## Truth Table

Sel	V <sub>Bus</sub>	L/D2-, R/D2+	D1+, D1-
Low	Low	ON	OFF
Low	High	OFF	ON
High	X	ON	OFF



# DIO3202A

USB2.0 High-Speed and Audio Switch with Negative Swing Capacity

## Absolute Maximum Ratings

Stresses beyond those listed under "Absolute Maximum Rating" may cause permanent damage to the device. These are stress ratings only and functional operation of the device at these or any other condition beyond those indicated in the operational sections of the specifications is not implied. Exposure to absolute maximum rating conditions for extended periods may affect device reliability.

Symbol	Parameter	Rating	Unit	
$V_{CC}$	Supply Voltage	-0.5 to 6.5	V	
$V_{BUS}$	$V_{BUS}$ Control Input Voltage	-0.5 to 6.5	V	
$V_{IN}$	$A_{SEL}$ Control Input Voltage	-0.5 to 6.5	V	
$V_{SW}$	USB Path Analog Signal Voltage	-0.5 to 6.5	V	
	Audio Path Analog Signal Voltage	-2.5 to 6.5		
	Storage Temperature	-65 to 150	°C	
$I_{IN}$	$A_{SEL}$ Control Input Current	5	μA	
	$V_{BUS}$ Control Input Current	5		
$I_{SW\_CON}$	Analog Signal Continuous Current	±100	mA	
$I_{SW\_PK}$	Analog Signal Peak Current	±500	mA	
ESD	HBM, JEDEC: JESD22-A114	I/O to GND	4	kV
		Others	8	

## Recommend Operating Conditions

The Recommended Operating Conditions table defines the conditions for actual device operation. Recommended Operating conditions are specified to ensure optimal performance to the datasheet specifications. DIOO does not Recommend exceeding them or designing to Absolute Maximum Ratings.

Symbol	Parameter	Rating	Unit
$V_{CC}$	Supply Voltage	2.7 to 5.5	V
$V_{IN}$	$V_{BUS}$ Control Input Voltage	0 to 5.5	V
	$A_{SEL}$ Control Input Voltage	0 to $V_{CC}$	
$V_{SW}$	USB to COM Analog Signal Voltage	0 to $V_{CC}$	V
	Audio to COM Analog Signal Voltage	-2 to $V_{CC}$	
$T_A$	Operating Temperature Range	-40 to 85	°C



# DIO3202A

USB2.0 High-Speed and Audio Switch with Negative Swing Capacity

## DC Electrical Characteristics

All typical value are at  $T_A = 25^\circ\text{C}$  unless otherwise specified.

Symbol	Parameter	Conditions	Min.	Typ.	Max.	Unit
<b>CONTROL INPUT</b> ( $T_A=25^\circ\text{C}$ , $V_{CC}=3.3\text{V}$ )						
$V_{IH}$	$A_{SEL}$ Control Input High Voltage	$V_{CC}=2.7\text{-}4.2\text{V}$	1.3			V
$V_{IL}$	$A_{SEL}$ Control Input Low Voltage	$V_{CC}=2.7\text{-}4.2\text{V}$			0.7	V
$I_{IN}$	$A_{SEL}$ Control Input Leakage Current	$0 \leq V_{SW} \leq V_{CC}$	-2		2	$\mu\text{A}$
$V_{IH}$	$V_{BUS}$ Control Input High Voltage	$V_{CC}=2.7\text{-}4.2\text{V}$	3.5			V
$V_{IL}$	$V_{BUS}$ Control Input Low Voltage	$V_{CC}=2.7\text{-}4.2\text{V}$			2.3	V
$I_{IN}$	$V_{BUS}$ Control Input Leakage Current	$0 \leq V_{SW} \leq V_{CC}$	-2		2	$\mu\text{A}$
<b>SUPPLY CURRENT AND LEAKAGE</b> ( $T_A=25^\circ\text{C}$ , $V_{CC}=3.3\text{V}$ )						
$I_{D+}, I_{D-}$ (OFF)	Off State Leakage	$V_{CC}=4.2\text{V}$ , $V_{BUS} = 0\text{V}$ , $V_{SEL} = 4.2\text{V}$ ; $V_{COM-}, V_{COM+} = 0\text{V}$ , $4.2\text{V}$ ; $V_{D+}, V_{D-} = 4.2\text{V}, 0\text{V}$ ; $V_L$ and $V_R = \text{float}$			80	nA
$I_{COM(ON)}$	On State Leakage	$V_{CC}=4.2\text{V}$ ; $V_{COM-}, V_{COM+} = 0\text{V}, 4.2\text{V}$ ; $V_{D+}, V_{D-} = \text{float}$ ; $V_L, V_R = \text{float}$			100	nA
$I_{CC}$	Quiescent Supply			95	120	$\mu\text{A}$
<b>AUDIO SWITCHES (R, L)</b> ( $T_A=25^\circ\text{C}$ , $V_{CC}=3.3\text{V}$ )						
$R_{ON}$	On Resistance	$I_{ON}=40\text{mA}$ , $V_{SW}=-0.85$ to $0.85\text{V}$		2	2.5	$\Omega$
$\Delta R_{ON}$	On Resistance Matching	$I_{ON}=40\text{mA}$ , $V_{SW}=-0.85$ to $0.85\text{V}$		0.5		$\Omega$
<b>USB SWITCHES (D+, D-)</b> ( $T_A=25^\circ\text{C}$ , $V_{CC}=3.3\text{V}$ )						
$R_{ON}$	On Resistance	$I_{ON}=8\text{mA}$ , $V_{SW}=0.4\text{V}$		4	4.5	$\Omega$
$\Delta R_{ON}$	On Resistance Matching	$I_{ON}=8\text{mA}$ , $V_{SW}=0.4\text{V}$		0.5		$\Omega$



# DIO3202A

USB2.0 High-Speed and Audio Switch with Negative Swing Capacity

## Electrical Characteristics (Continued)

All typical value are at 25°C unless otherwise specified.

Symbol	Parameter	Conditions	Min.	Typ.	Max.	Unit
<b>AC Parameter</b> ( $T_A=25^\circ\text{C}$ , $V_{CC}=3.3\text{V}$ , $R_L=50\Omega$ , $C_L=5\text{pF}$ , unless otherwise specified)						
$t_{ON}$	USB Turn-on Time	$V_{CC}=2.7\text{V}$ , $R_L=50\Omega$ , $C_L=50\text{pF}$		16		$\mu\text{s}$
$t_{OFF}$	USB Turn-off Time	$V_{CC}=2.7\text{V}$ , $R_L=50\Omega$ , $C_L=50\text{pF}$		1.5		$\mu\text{s}$
$t_{ON}$	Audio Turn-on Time	$V_{CC}=2.7\text{V}$ , $R_L=50\Omega$ , $C_L=50\text{pF}$		24		$\mu\text{s}$
$t_{OFF}$	Audio Turn-off Time	$V_{CC}=2.7\text{V}$ , $R_L=50\Omega$ , $C_L=50\text{pF}$		1.2		$\mu\text{s}$
$T_{BBM}$	Break Before Make Time	$V_{CC}=2.7\text{V}$		7		$\mu\text{s}$
BW	-3dB Bandwidth USB Channel	$R_L=50\Omega$		720		MHz
OIRR	OFF-Isolation	$V_{CC}=3.3\text{V}$ , $R_L=32\Omega$ , $f = 20\text{Hz}$ to $20\text{kHz}$		105		dB
$X_{TALK}$	USB Crosstalk	$V_{CC}=3.3\text{V}$ , $R_L=50\Omega$ , $f=100\text{kHz}$		-100		dB
$X_{TALK}$	Audio Crosstalk	$V_{CC}=3.3\text{V}$ , $V_{BUS} = \text{float}$ , $V_{SEL}=3.3\text{V}$ , $R_L=32\Omega$ , $f=20\text{Hz}$ to $20\text{kHz}$ , $V_R$ or $V_L = 0.707V_{RMS}$ ( $2V_{PP}$ )		-80		dB
THD+N	Total Harmonic Distortion + Noise	$V_{BUS}=0\text{V}$ , $V_{SEL}=3.3\text{V}$ , $R_L=32\Omega$ , $f=20\text{Hz}$ to $20\text{kHz}$ , $V_{COM}=2V_{PP}$		0.08		%
<b>CAPACITANCE</b> ( $T_A=25^\circ\text{C}$ , $V_{CC}=3.3\text{V}$ , $R_L=50\Omega$ , $C_L=5\text{pF}$ , $f=1\text{MHz}$ , $A_{SEL}=0\text{V}$ , unless otherwise specified)						
$C_{IN}$	$A_{SEL}$ Control Input Capacitance	$V_{CC}=0\text{V}$		2		pF
$C_{ON}$	USB ON Capacitance	$f=1\text{MHz}$ , $V_{CC}=3.3\text{V}$ , $V_{BUS}=4.2\text{V}$ , $V_{SEL}=0\text{V}$ , $V_{D-}$ or $V_{D+} = V_{COMX}=0\text{V}$		5		pF
$C_{ON}$	Audio ON Capacitance	$V_{BUS}=0\text{V}$ , $V_{SEL}=3.3\text{V}$		9		pF
$C_{OFF}$	USB OFF Capacitance	$V_{BUS}=0\text{V}$ , $V_{SEL}=3.3\text{V}$		3		pF
$C_{OFF}$	Audio OFF Capacitance	$V_{BUS}=4.2\text{V}$ , $V_{SEL}=0\text{V}$		4		pF

## Applications Design Guide

DIO3202A is used in applications where the slim and thin smart phone designs are expected. By sharing the USB connector between USB2.0 data lines and audio headphone outputs, the designers can eliminate the using of bulky headphone jacks. Meanwhile, using the mini-USB connectors as audio outputs allows the end users to reduce the cost to buy too many different types of cell phone accessories.

DIO3202A unique architectures allow the part to allow the part to have constant  $R_{on}$ ,  $R_{on}$  (flatness) and THD performance independent of  $V_{cc}$  supply value. So in some applications such as mobile cell phone designs, if the designers want to achieve the lowest standby power consumption when the battery is turned OFF, it is highly recommended that DIO3202A be powered by 2.8V, no need of being powered by battery (4.3V) directly. This will help designers to be freed from the complex logic designs to ensure the part will get into sleep mode.

DIO3202A's control pins are 1.8V control logic compatible, so the parts can be controlled by baseband processor GPIO directly without worrying about the level shifting issues. Regarding high speed signal integrity, DIO3202A is recommended to be placed as close as possible to the USB controller outputs to reduce the signal reflection under high speed mode (480Mbps). In the meanwhile, the  $V_{cc}$  pin of DIO3202A is required to have decoupling capacitors to reduce the supply ripples.

The below is the DIO3202A USB 2.0 high speed (480Mbps) eye diagram compliance test under near-end mode (most challenging mode).

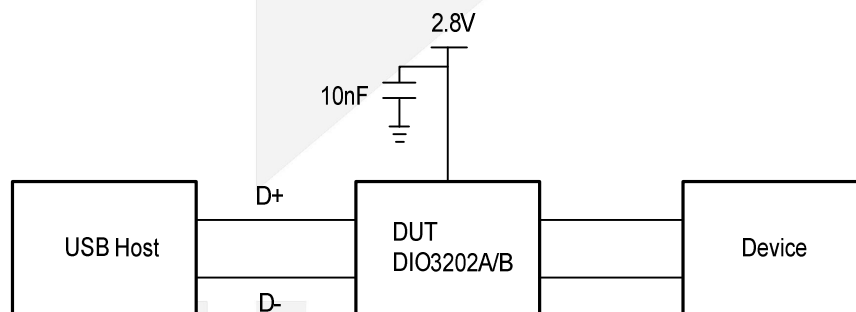

**Figure 2. USB2.0 high speed eye diagram test circuit**

DIO3202A is designed for -2V signal switch at all audio ports. If customer wants to pass signal up to -3V, design suggestions are:

1. Make sure when audio path (L/R ports) is ON, no signal should be applied at D+/D- port;
2. A Schottky diode is recommended between DIO3202A GND pin and system GND.

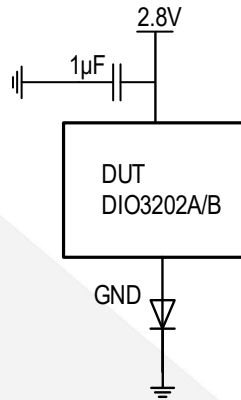

## DIO3202A USB 2.0 high speed (480Mbps) eye pattern

$T_A = 25^\circ\text{C}$ ,  $V_{CC} = 2.8\text{V}$ , unless otherwise specified.

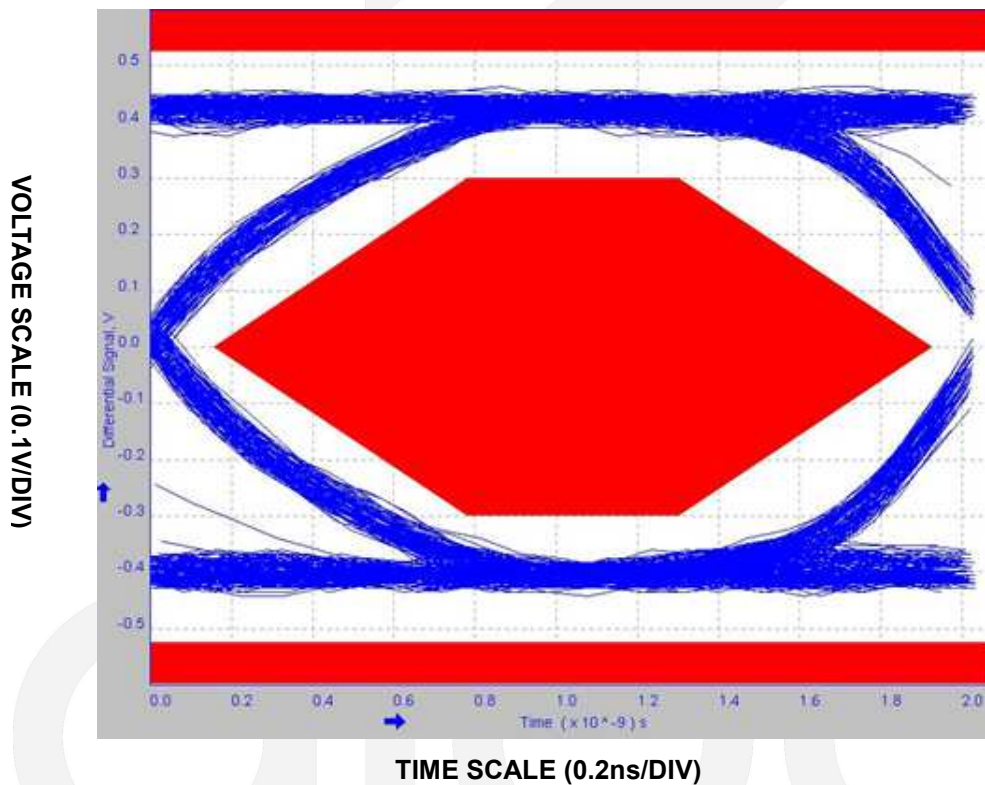

Figure 3. Eye Pattern: 480Mbps with USB switch In signal path

## CONTACT US

**Dioo** is a professional design and sales corporation for high-quality and performance analog semiconductors. The company focuses on industry markets, such as, cell phone, handheld products, laptop, and medical equipment and so on. Dioo's product families include analog signal processing and amplifying, LED drivers and charger IC. Go to <http://www.dioo.com> for a complete list of Dioo product families.

For additional product information, or full datasheet, please contact with our Sales Department or Representatives.





## X-ON Electronics

Largest Supplier of Electrical and Electronic Components

*Click to view similar products for [USB Switch ICs category](#):*

*Click to view products by [Dioo manufacturer](#):*

Other Similar products are found below :

[NLAS7213MUTBG](#) [FSA221UMX](#) [FSUSB31UMX](#) [FSA806UMX](#) [NLAS7222AMTR2G](#) [TC7USB3212WBG\(ELAH](#) [PI3USB31531ZLCEX](#)  
[PI3USB31532ZLCEX](#) [BD91N01NUX-E2](#) [MP5030DGQH-Z](#) [NL3S22AHMUTAG](#) [NL3S22UHMUTAG](#) [NCN1154MUTAG](#)  
[NLAS7242MUTBG](#) [HD3SS460RHRT](#) [TS5USBC402IYFPT](#) [NS5S1153MUTAG](#) [FSUSB11MTCX](#) [FSUSB42MUX](#) [FT234XD-R](#)  
[PI3USB102GZLEX](#) [P6KE110A](#) [SMAJ200A](#) [SMAJ70CA](#) [SMAJ11A](#) [SMAJ14A](#) [SMAJ160CA](#) [SMAJ250A](#) [SMAJ51CA](#) [SMAJ5.0CA](#)  
[ISL54216IRTZ](#) [30KP400CA](#) [1SMB5.0AT3G](#) [MAX4717ETB+T](#) [MAX4989ETD+T](#) [MAX4717EBCT](#) [MAX4717EUB+](#) [MAX4906ELB+T](#)  
[MAX4899EETE+](#) [MAX4906EFELB+T](#) [MAX4907FELA+T](#) [MAX4907ELA+T](#) [MAX4983EEVB+T](#) [MAX4984EEVB+T](#)  
[MAX4899AEETE+T](#) [MAX14618ETA+T](#) [MAX14651ETA+T](#) [MAX14617ETA+T](#) [MAX14640ETA+T](#) [MAX14600ETA+T](#)