

DIO3350

USB 3.1/3.0 Super-Speed 11Gbps Switch

Features

- Wide V_{DD} Input Voltage Range: 1.5V to 5.0V
- Up to 11 Gbps for applications including USB3.0, USB3.1, 10GE, Thunderbolt, and SAS3.0
- Bi-directional operation
- Bandwidth: 11GHz(Typical)
- -0.9dB Typical Insertion Loss at 2.5GHz
- Low Active Power of 15 μ A Typ. @ 3.6V V_{IN}
- Low Shutdown Power of < 0.5 μ A Max.
- Low Crosstalk: -55dB @2.5GHz
- Low Off Isolation: -27dB @ 2.5GHz
- Operation Temperature Range: -40°C to 85 °C
- 2.5KV HBM ESD Protection
- Packaged in QFN2.6*1.8-16, QFN2.5*4.5-20 and QFN2*2-18

Descriptions

The DIO3350 is a two pairs 2:1 data switch for USB Super Speed Gen1 and Gen2, 5 Gbps and 10 Gbps data. The DIO3350 focus on the mobile device market, for the use in Type-C applications as a reversible cable switch. It can minimize the switch channel to channel skew and channel to channel crosstalk of the super speed signals.

The DIO3350 data switches offer superior performance, support various high speed data transmission protocols, such as USB3.0, USB3.1, 10GE, Thunderbolt, and SAS3.0.

Applications

- Smartphones
- Tablets
- Notebooks

Block Diagram

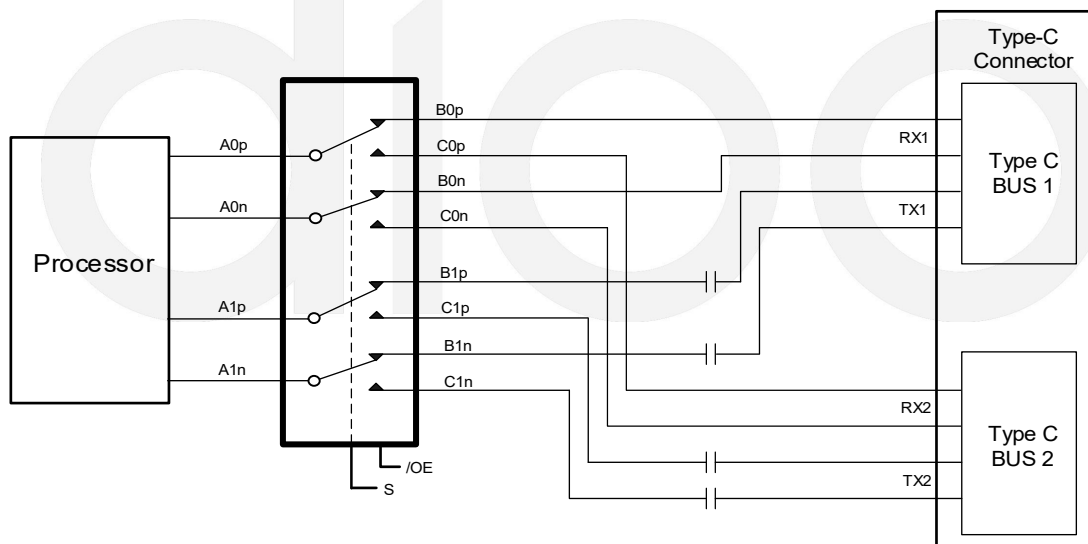

Ordering Information

Order Part Number	Top Marking		T _A	Package	
DIO3350LN16	D3EV	Green	-40 to 85°C	QFN2.6*1.8-16	Tape & Reel, 3000
DIO3350CN18	D3EV	Green	-40 to 85°C	QFN2*2-18	Tape & Reel, 3000
DIO3350AEN20	D3EA	Green	-40 to 85°C	QFN2.5*4.5-20	Tape & Reel, 5000
DIO3350BEN20	D3EB	Green	-40 to 85°C	QFN2.5*4.5-20	Tape & Reel, 5000

Pin Assignment

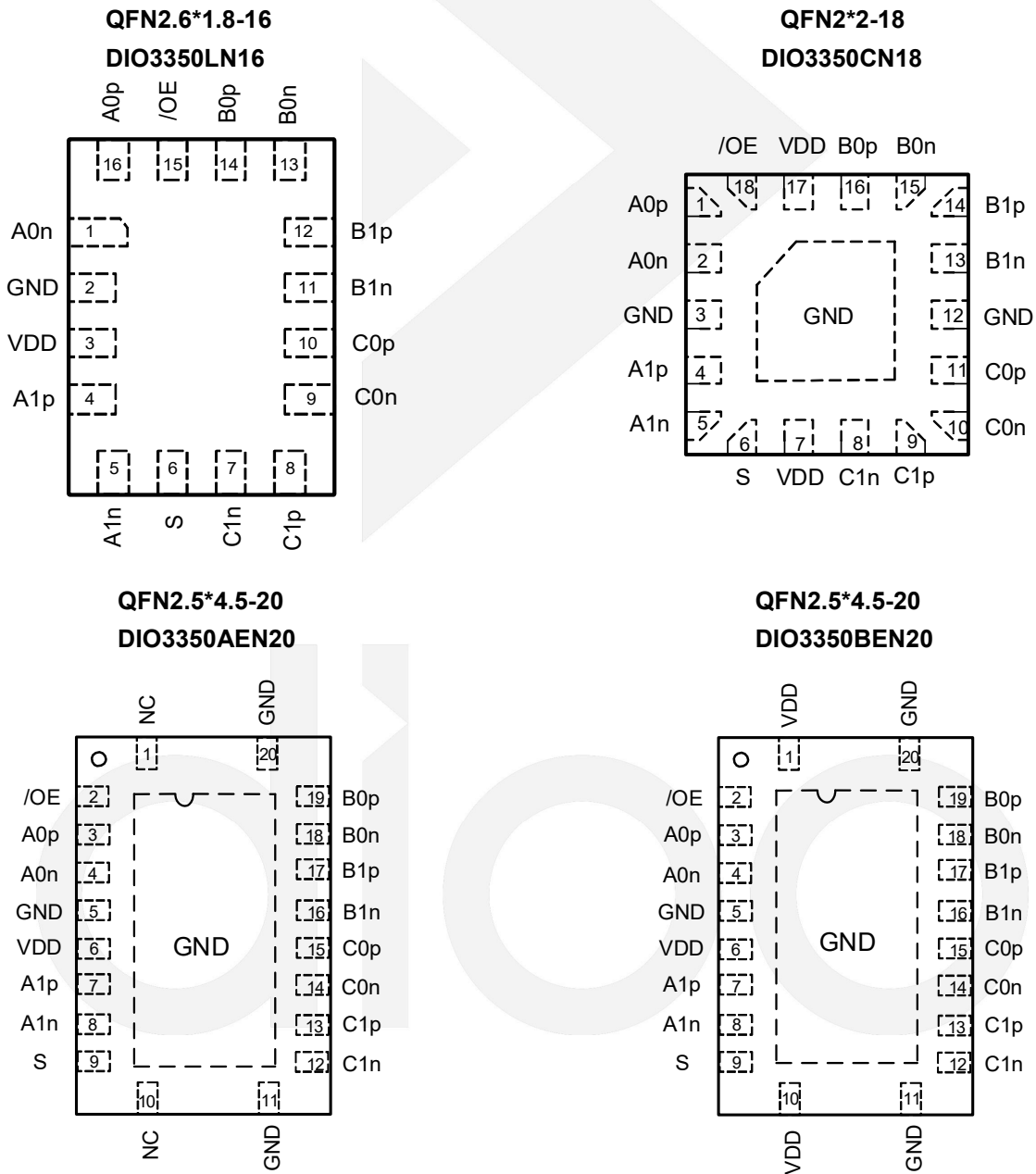

Figure 1 Top View

Pin Descriptions

Pin Name	Type	Description
A0n	I/O	Port A, channel 0, high-speed negative signal
A1p	I/O	Port A, channel 1, high-speed positive signal
A1n	I/O	Port A, channel 1, high-speed negative signal
S	I	Switch Select (L: Port A to Port B; H: Port A to Port C)
C1n	I/O	Port C, channel 1, high-speed negative signal (connector side)
C1p	I/O	Port C, channel 1, high-speed positive signal (connector side)
C0n	I/O	Port C, channel 0, high-speed negative signal (connector side)
C0p	I/O	Port C, channel 0, high-speed positive signal (connector side)
B1n	I/O	Port B, channel 1, high-speed negative signal (connector side)
B1p	I/O	Port B, channel 1, high-speed positive signal (connector side)
B0n	I/O	Port B, channel 0, high-speed negative signal (connector side)
B0p	I/O	Port B, channel 0, high-speed positive signal (connector side)
A0p	I/O	Port A, channel 0, high-speed positive signal
/OE	I	Output Enable (0=Switches Enabled, 1=Switches Disabled)
VDD	VDD	Device Power
GND	GND	Ground
NC	NC	No connected



Absolute Maximum Ratings

Stresses beyond those listed under "Absolute Maximum Rating" may cause permanent damage to the device. These are stress ratings only and functional operation of the device at these or any other condition beyond those indicated in the operational sections of the specifications is not implied. Exposure to absolute maximum rating conditions for extended periods may affect device reliability.

Symbol	Parameter	Rating	Unit
V _{DD}	Supply Voltage	-0.5 to 6.0	V
V _{CNTRL}	DC Input Voltage (S, /OE) ⁽¹⁾	-0.5 to V _{DD}	V
V _{SW}	DC Switch I/O Voltage ^(1,2)	-0.3 to 2.1	V
I _{IK}	DC Input Diode Current	-50	mA
I _{SW}	DC Switch Current	25	mA
T _{STG}	Storage Temperature	-65 to 150	°C
ESD	Human Body Model, JEDEC: JESD22-A114	4	kV

Note:

1. The input and output negative ratings may be exceeded if the input and output diode current ratings are observed.
2. V_{SW} refers to analog data switch paths.

Recommend Operating Conditions

The Recommended Operating Conditions table defines the conditions for actual device operation. Recommended Operating conditions are specified to ensure optimal performance to the datasheet specifications. DIOO does not Recommend exceeding them or designing to Absolute Maximum Ratings.

Symbol	Parameter	Rating	Unit
V _{DD}	Supply Voltage	1.5 to 5.0	V
V _{CNTRL}	Control Input Voltage (S, /OE) ⁽³⁾	0 to 5.0	V
V _{SW}	Switch I/O Voltage (Both SSUSB Switch Paths)	0 to 2.0	V
T _A	Operating Temperature Range	-40 to 85	°C

Note:

3. The control inputs must be held HIGH or LOW; they must not float.

DC and Transient Characteristics

All typical values are at $T_A=25^{\circ}\text{C}$ unless otherwise specified.

Symbol	Parameter	Conditions	$V_{DD}(\text{V})$	Min.	Typ.	Max.	Unit
V_{IH}	Control Input Voltage High	S, /OE	1.5	1.3			V
		S, /OE	3.6	1.4			
		S, /OE	5.0	1.5			
V_{IL}	Control Input Voltage Low	S, /OE	1.5			0.4	V
		S, /OE	3.6			0.4	
		S, /OE	5.0			0.4	
I_{IN}	Control Input Leakage	$V_{SW} = -0.6$ to 2.0V $V_{CNTRL} = 0$ to V_{DD}	5.0	-500		500	nA
I_{OZ}	Off-State Leakage for Open Data Paths	$V_{SW} = 0.0 \leq \text{DATA} \leq 2.0\text{V}$	5.0	-0.5		0.5	μA
I_{CL}	On-State Leakage for Closed Data Paths ⁽⁴⁾	$V_{SW} = 0.0 \leq \text{DATA} \leq 2.0\text{V}$	5.0	-0.5		0.5	μA
I_{OFF}	Power-Off Leakage Current (All I/O Ports)	$V_{SW} = 0\text{V}$ or 2.0V	0	-500		500	nA
R_{ON}	Switch On Resistance	$V_{SW} = 0.2\text{V}$, $I_{ON} = -8\text{mA}$	1.5		6	8	Ω
ΔR_{ON}	Difference in R_{ON} Between Positive-Negative	$V_{SW} = 0.2\text{V}$, $I_{ON} = -8\text{mA}$	1.5		0.1		Ω
R_{ONF}	Flatness for R_{ON}	$V_{SW} = 0.0 \leq \text{DATA} \leq 2.0\text{V}$, $I_{ON} = -8\text{mA}$	1.5			0.5	Ω
I_{CC}	Quiescent Supply Current	$V_{IOE} = 0$, $V_{SEL} = 0$ or V_{DD} , $I_{OUT} = 0$	5.0		21	30	μA
I_{CCZ}	Quiescent Supply Current (High Impedance)	$V_{SEL} = X$, $V_{IOE} = V_{DD}$, $I_{OUT} = 0$	5.0			0.5	μA
I_{CCT}	Increase in Quiescent Supply Current per V_{CNTRL}	V_{SEL} or $V_{IOE} = 1.5\text{V}$	5.0		7	15	μA

Note:

4. For this test, the data switch is closed with the respective switch pin floating.

AC Electrical Characteristics

All typical values are at $V_{DD}=3.6V$, $T_A=25^{\circ}C$ unless otherwise specified.

Symbol	Parameter	Conditions	$V_{DD}(V)$	Min.	Typ.	Max.	Unit
t_{ON}	Turn-On Time, S to Output	$R_L=50\Omega$, $C_L=0pF$, $V_{SW}=0V$, $V_{SW}=0.6V$	1.5 to 5.0V		420	700	ns
t_{OFF}	Turn-Off Time, S to Output	$R_L=50\Omega$, $C_L=0pF$, $V_{SW}=0V$, $V_{SW}=3.3V$	1.5 to 5.0V		100	300	ns
$t_{ZHM,ZL}$	Enable Time,/OE to Output	$R_L=50\Omega$, $C_L=0pF$, $V_{SW}=0.6V$	1.5 to 5.0V		53	150	μs
$t_{LZM,HZ}$	Disable Time,/OE to Output	$R_L=50\Omega$, $C_L=0pF$, $V_{SW}=0.6V$	1.5 to 5.0V		100	300	ns
t_{PD}	Propagation Delay ⁽⁵⁾	$C_L=0pF$, $R_L=50\Omega$	1.5 to 5.0V		60		ps
t_{BBM}	Break-Before-Make ⁽⁵⁾	$R_L=50\Omega$, $C_L=0pF$, $V_{SW}=0.6V$	1.5 to 5.0V	120		600	ns
DO _{IRR}	Differential Off Isolation ⁽⁵⁾	$V_S=0dBm$, $R_L=50\Omega$, $f=2.5GHz$	3.6V		-27		dB
		$V_S=0dBm$, $R_L=50\Omega$, $f=5.0GHz$			-20		dB
SDDNEXT	Differential Channel Crosstalk ⁽⁵⁾	$V_S=0dBm$, $R=50\Omega$, $f=2.5GHz$	3.6V		-55		dB
		$V_S=0dBm$, $R=50\Omega$, $f=5.0GHz$			-47		dB
DIL	Differential Insertion Loss(All Data Paths) ⁽⁵⁾	$V_{IN}=0dBm$, $f=2.5GHz$, $R_L=50\Omega$, $C_L=0pF$	3.6V		-0.9		dB
		$V_{IN}=0dBm$, $f=5.0GHz$, $R_L=50\Omega$, $C_L=0pF$			-1.4		dB
BW	Differential -3dB Bandwidth ⁽⁵⁾	$V_{IN}=1$ Vpk-pk, $R_L=50\Omega$, $C_L=0pF$, (Both Data Paths)	3.6V		11		GHz
Tsk(P)	Skew of Opposite Transitions of the Same Output ⁽⁵⁾	$R_{PU}=50\Omega$ to V_{DD} , $C_L=0pF$	3.6V		6		ps
C_{IN}	Control Pin Input Capacitance ⁽⁵⁾	$V_{DD}=0V$, $f=1MHz$			2.7		pF
C_{ON}	On Capacitance ⁽⁵⁾	$V_{DD}=3.3V$, $f=2.5GHz$			0.45		pF
C_{OFF}	Off Capacitance ⁽⁵⁾	$V_{DD}=3.3V$, $f=2.5GHz$			0.36		pF

Note:

5. Guaranteed by characterization.

Typical Performance Characteristics

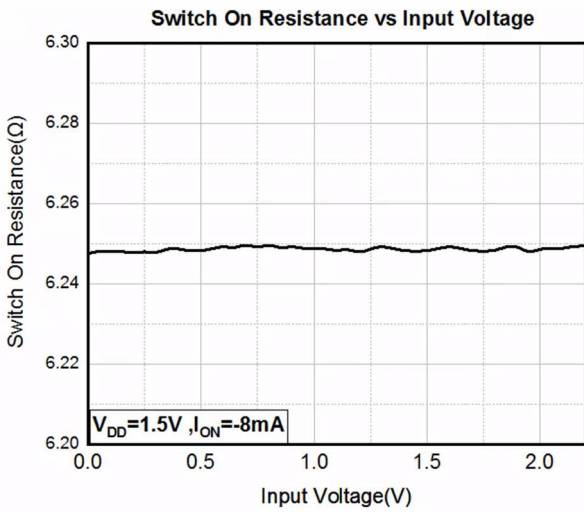

Figure 2 R_{ON} VS. V_{IN}

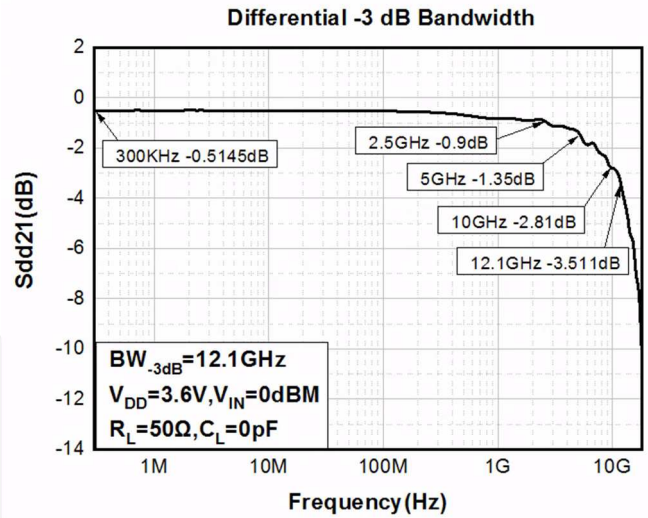

Figure 3 Different -3dB Bandwidth

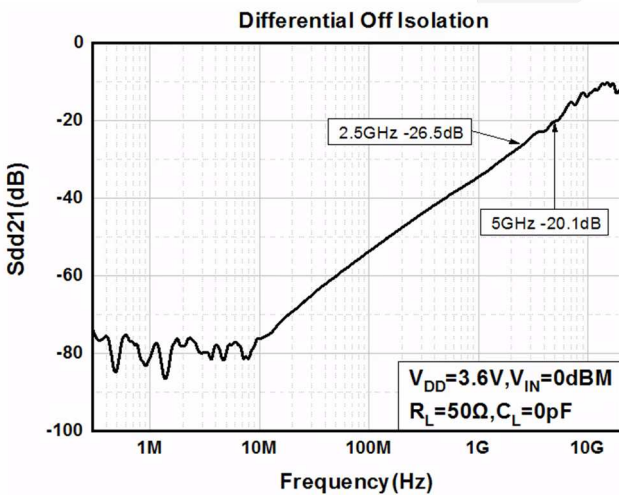

Figure 4 Different Off Isolation

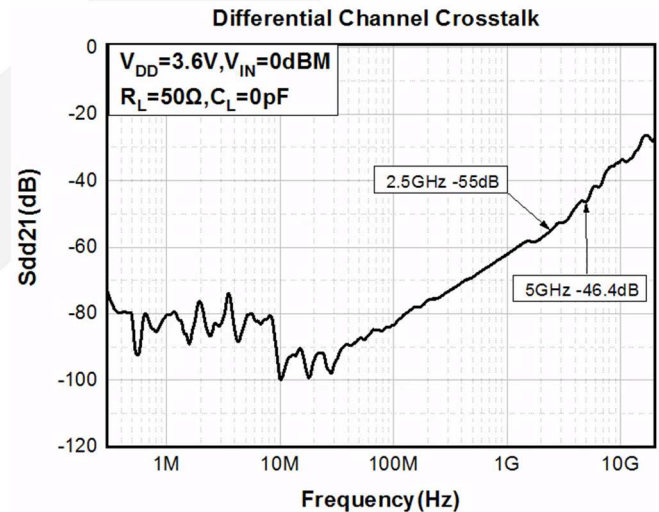

Figure 5 Differential Channel Crosstalk

Before Switch

After Switch

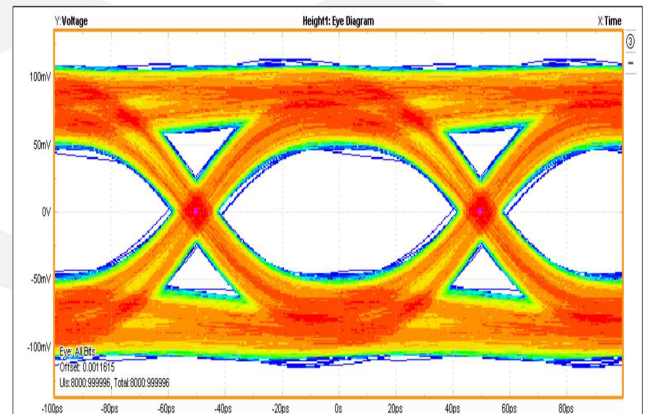
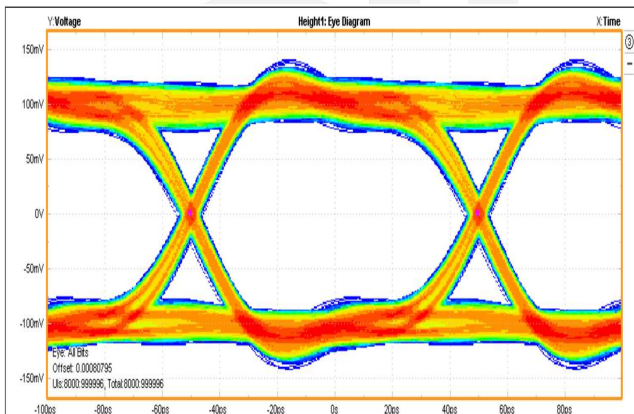

Figure 6 Eye Opening at 10Gb/s using PRBS15 pattern

Typical Applications

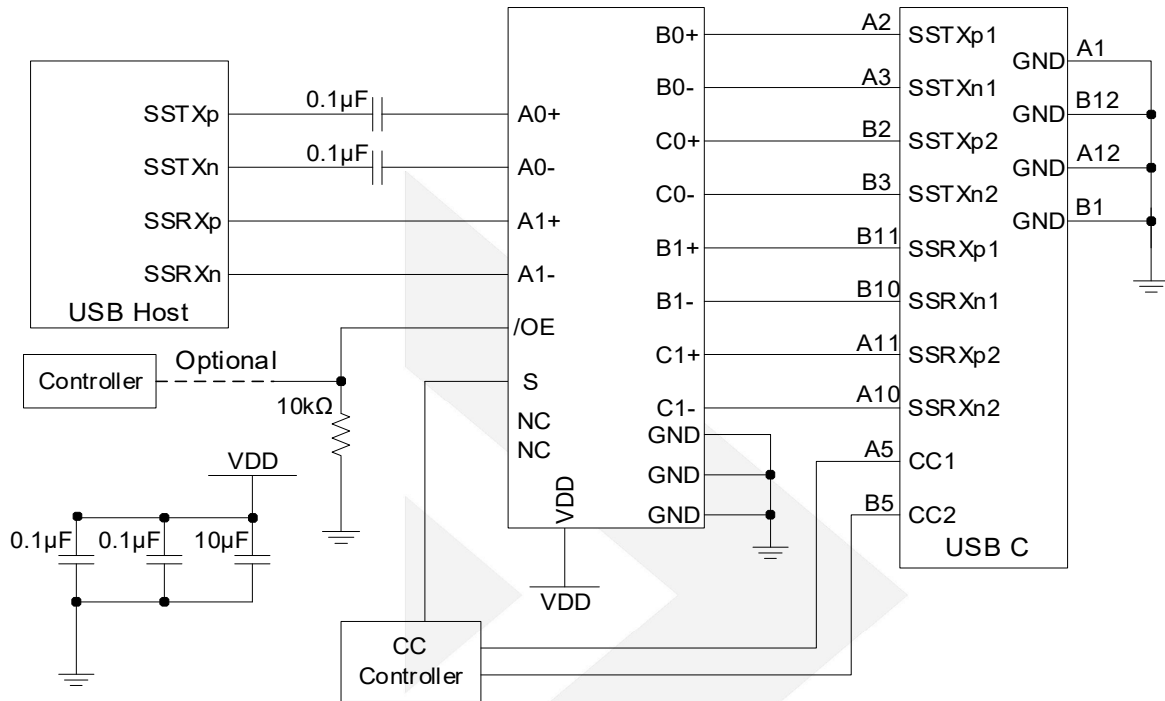

Figure 7. Down Facing Port for USB3.1 Type C Connector

Systems Examples

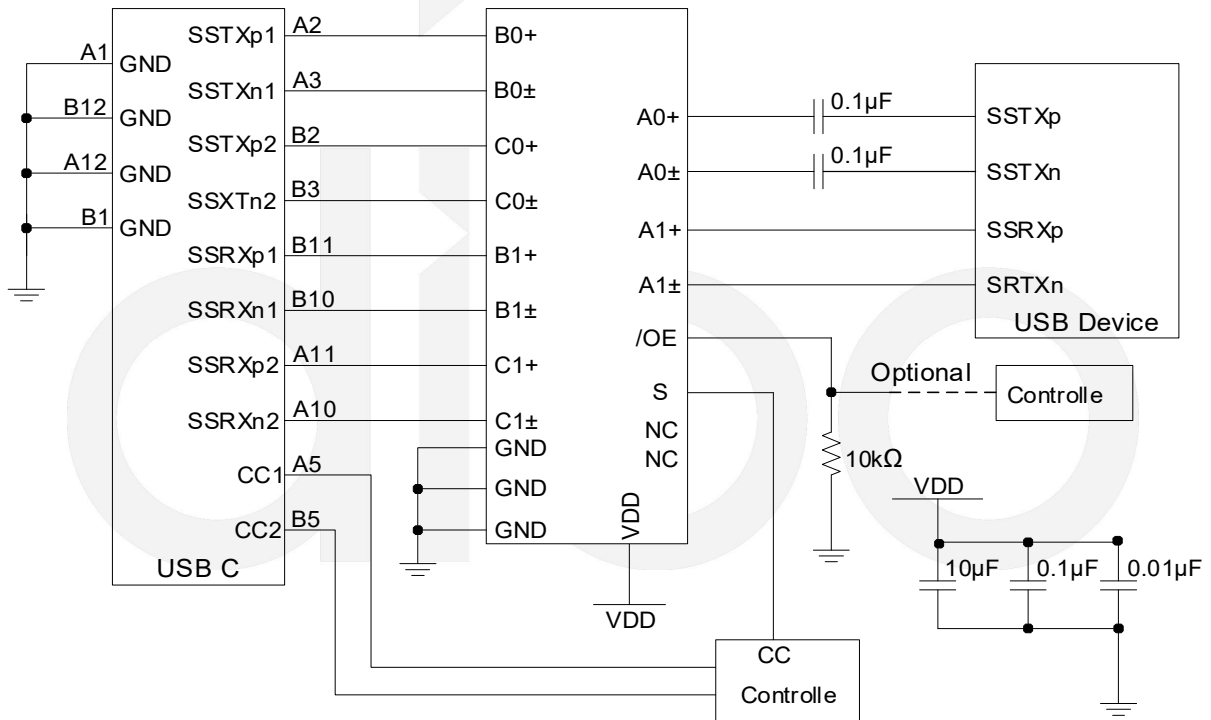

Figure 8. Up Facing Port for USB3.1 USB Type-C Connector

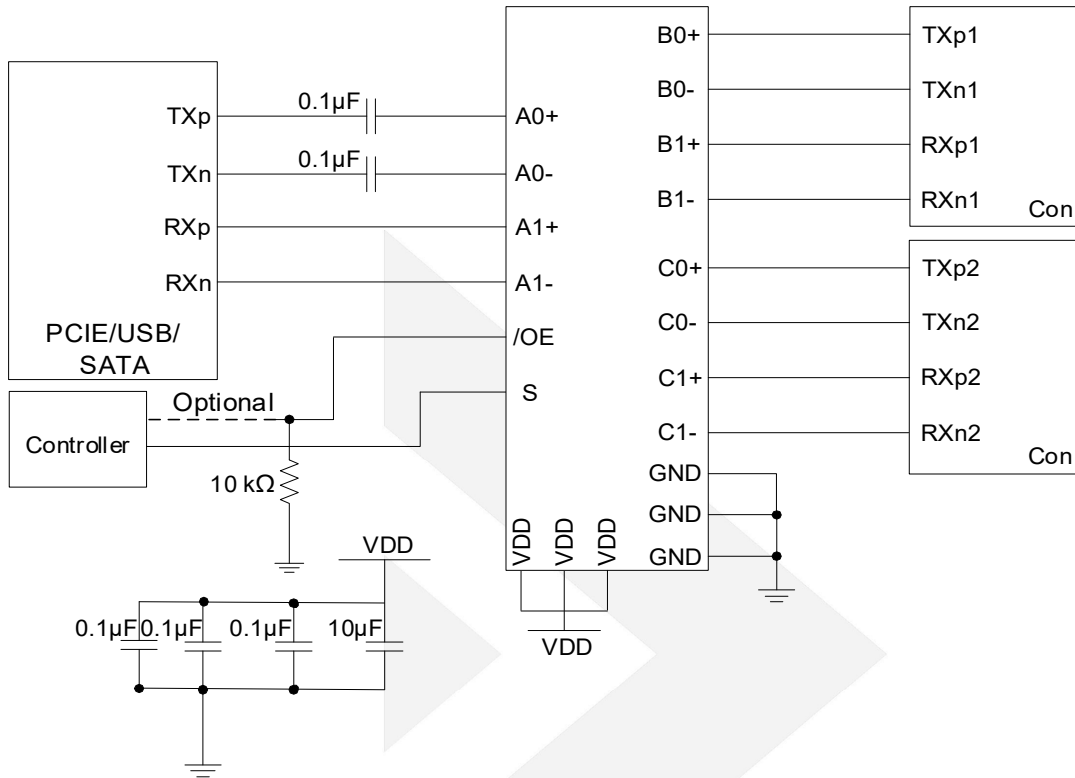

Figure 9. PCIE Motherboard

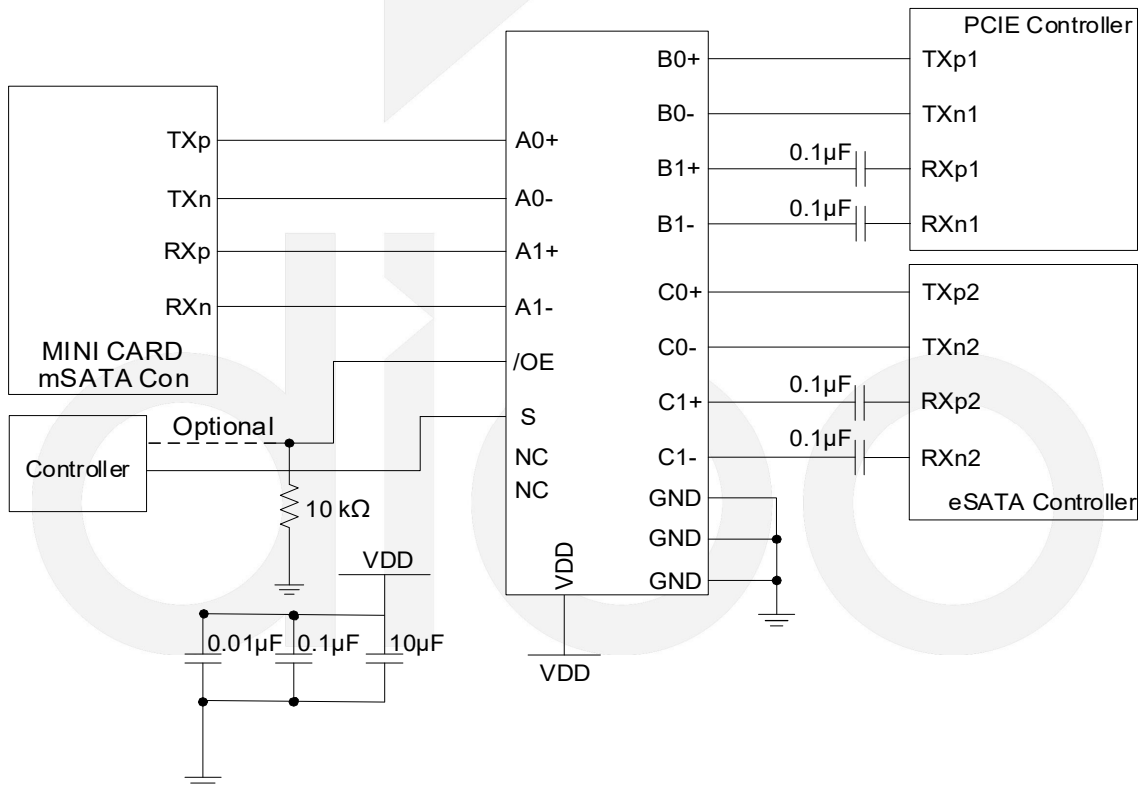

Figure 10. PCIE and eSATA Combo

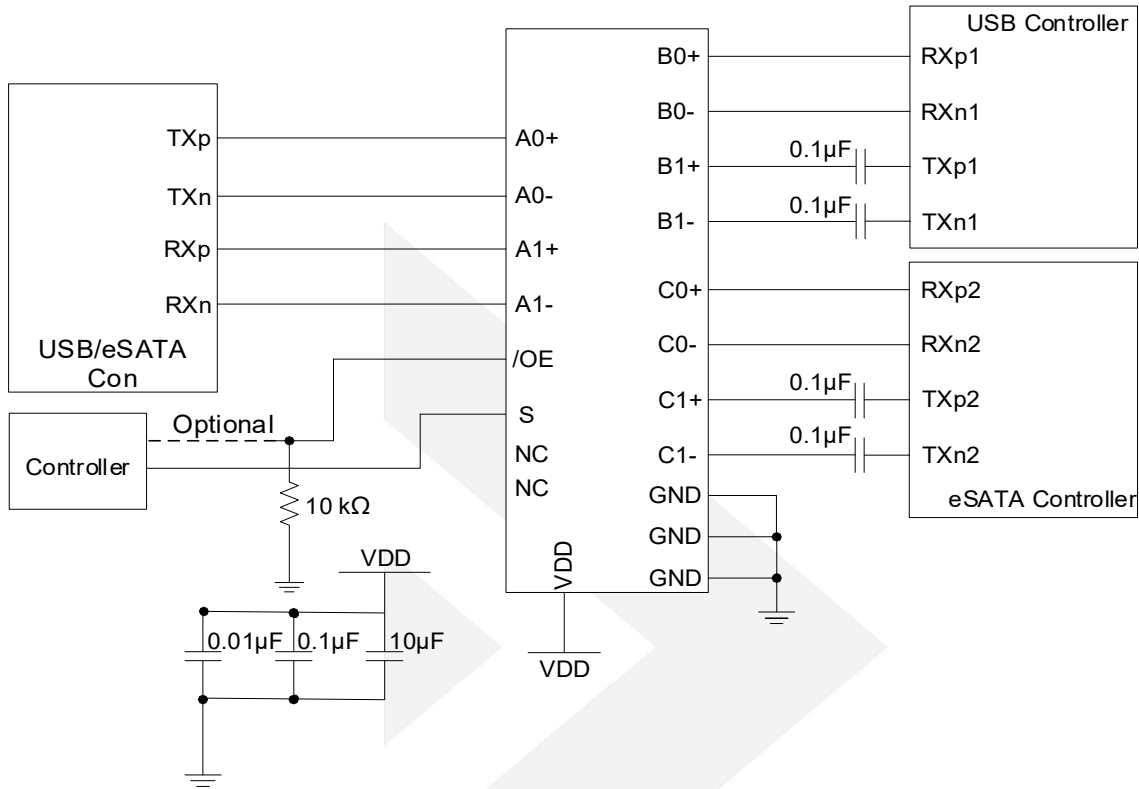

Figure 11. eSATA and USB 3.0 Combo Connector

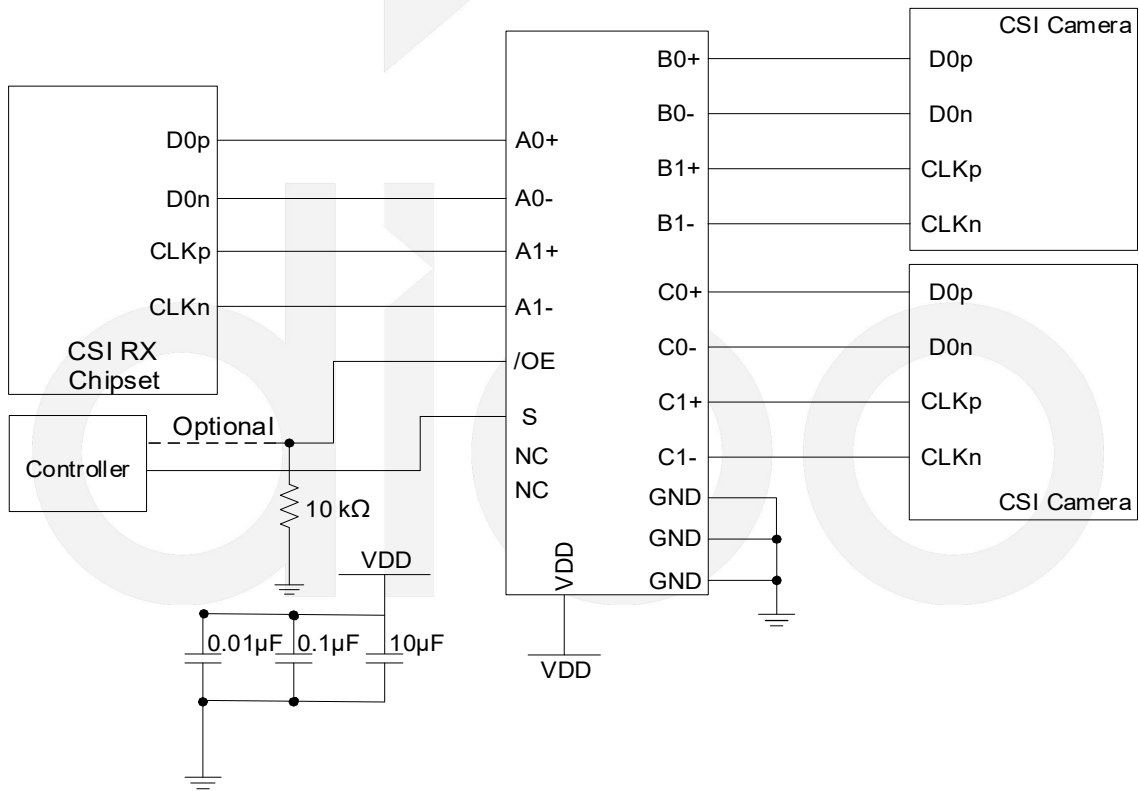

Figure 12. CSI Camera Array

CONTACT US

Dioo is a professional design and sales corporation for high-quality and performance analog semiconductors. The company focuses on industry markets, such as, cell phone, handheld products, laptop, and medical equipment and so on. Dioo's product families include analog signal processing and amplifying, LED drivers and charger IC. Go to <http://www.dioo.com> for a complete list of Dioo product families.

For additional product information, or full datasheet, please contact with our Sales Department or Representatives.

A large, light gray watermark of the Dioo logo is centered on the page. It consists of a stylized arrow pointing right above the word "dioo" in a lowercase, sans-serif font.

X-ON Electronics

Largest Supplier of Electrical and Electronic Components

Click to view similar products for [USB Interface IC](#) category:

Click to view products by [Dioo](#) manufacturer:

Other Similar products are found below :

[CYUSB2304-68LTXI](#) [CYPD2120-24LQXI](#) [CYUSB3014-BZXCT](#) [CYWB0164BB-BZXI](#) [CYWB0224ABS-BZXI](#) [CP2102NP1174GM](#)
[CYPD2119-24LQXIT](#) [CY7C65621-56LTXIT](#) [CY7C65631-56LTXIT](#) [DPO2039DABQ-13](#) [CYPD5225-96BZXIT](#) [UPD720201K8-711-BAC-A](#)
[CYPD5235-96BZXIT](#) [CYPD3196-24LDXS](#) [UPD720115K8-611-BAK-A](#) [UPD720115K8-711-BAK-A](#) [UPD720211K8-711-BAL-A](#)
[PI2DPX1217XUAEX](#) [UPD720211K8-611-BAL-A](#) [CY7C65223D-32LTXI](#) [CYPD6127-48LQXIT](#) [WUSB3801Q-12/TR](#) [FT232BL-JSM](#)
[PL2303GC](#) [PL2586](#) [VL152-WLCSP](#) [CH344Q](#) [USB5744B-I/2GX01](#) [TUSB1044RNQR](#) [TPS25830AQCWRHBRQ1](#) [TUSB544IRNQR](#)
[TPS25830AQWRHBRQ1](#) [FP6606ACDW4](#) [VL151\(A3\)-W](#) [CH334U](#) [CH9101U](#) [CH9101N](#) [CH334S](#) [ISOUSB211DPR](#) [CH348L](#) [RH7803](#)
[XPD977D30A](#) [RTS5411T-GR](#) [NB7NPQ1404E2MMUTWG](#) [CH344L](#) [CH9340K](#) [TPS25730SRSMR](#) [CH348Q](#) [DIO3350AEN20](#)
[TUSB1210BRHBTQ1](#)