

## DIO3712

# High-bandwidth and Low on-resistance Analog switch

### Features

- Over-Voltage Tolerance (OVT)
- Voltage Operation: 1.8V to 5.5V
- Low On Resistance: 4.5Ω typ at 4.5Vcc
- High Off-Isolation
- Low Crosstalk
- Low leakage current
- Low power consumption
- Wide -3dB Bandwidth: >300MHz
- Low Distortion
- Packaged: DQFN-10, MSOP-10
- 8kV HBM; 1.5kV CDM ESD Rating

### Applications

- Cell Phones
- PDAs and MP3s
- Portable Instrumentation
- Battery Powered Communications
- Computer Peripherals

### Descriptions

DIO3712 is a dual, bidirectional, single-pole/double-throw (SPDT) CMOS analog switch, which is designed to operate from a single 1.8V to 5.5V supply. It features high-bandwidth (300MHz) and low on-resistance, targeted applications for full speed USB and audio switching.

DIO3712 features power ON/OFF protection effectively protecting device against external signal perturbation. It also offers excellent -3db bandwidth and lower ON resistance, which can be used as analog switch in multiple applications.

It operates under wide Vcc supply from 1.8V to 5.5V, consuming very low quiescent current even when the voltage of S pin is lower than Vcc supply. This new feature services the mobile handset applications very well allowing for the direct interface with baseband processor general purpose I/Os with no need of level translator.

### Block Diagram

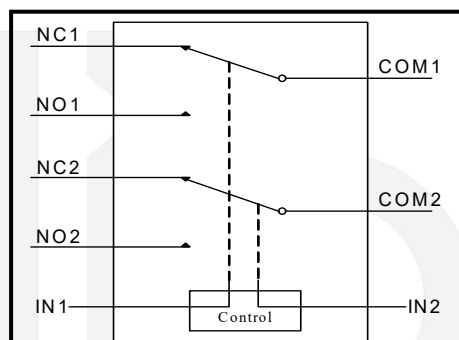

### Ordering Information

Order Part Number	Top Marking	Green	T <sub>A</sub>	Package	
DIO3712LP10	YWGM	Yes	-40 to 85°C	DQFN-10	Tape & Reel, 3000
DIO3712MP10	DIO3712	Yes	-40 to 85°C	MSOP-10	Tape & Reel, 3000

# DIO3712

High-bandwidth and Low on-resistance Analog switch

## Pin Assignment

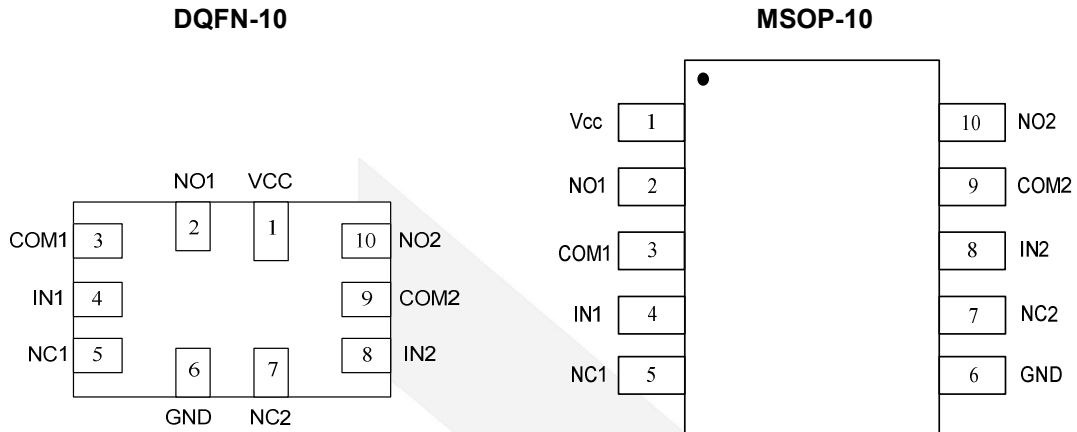

Figure 1 Top View

## Pin Descriptions

Pin Name	Description
Vcc	Power Supply
GND	Ground
COM1, COM2	Common Port
NO1, NO2	Data Port
NC1, NC2	Data Port
IN1, IN2	Control Port

## Truth Table

IN	Function
1	COM Connected to NO
0	COM Connected to NC

# DIO3712

## Absolute Maximum Ratings

Stresses beyond those listed under “Absolute Maximum Rating” may cause permanent damage to the device. These are stress ratings only and functional operation of the device at these or any other condition beyond those indicated in the operational sections of the specifications is not implied. Exposure to absolute maximum rating conditions for extended periods may affect device reliability

Symbol	Parameter	Min.	Max.	Unit
V <sub>CC</sub>	Supply Voltage	-0.3	6	V
V <sub>S</sub>	DC Switch Voltage	-0.3	V <sub>CC</sub> +0.3	V
V <sub>IN</sub>	DC Input Voltage	-0.3	V <sub>CC</sub> +0.3	V
I <sub>SW</sub>	Switch Current		±50	mA
I <sub>SWpeak</sub>	Peak Switch Current (Pulse at 1ms duration, <10% Duty Cycle)		±80	mA
T <sub>STG</sub>	Storage Temperature Range	-65	150	°C
T <sub>J</sub>	Junction Temperature		150	°C
T <sub>L</sub>	Lead Temperature Range		260	°C
ESD	HBM, JEDEC: JESD22-A114		8	kV
	CDM, JEDEC: JESD22-C101		1.5	

## Recommend Operating Conditions

The Recommended Operating Conditions table defines the conditions for actual device operation. Recommended Operating conditions are specified to ensure optimal performance to the datasheet specifications. DIOO does not Recommend exceeding them or designing to Absolute Maximum Ratings.

Symbol	Parameter	Min.	Max.	Unit
V <sub>CC</sub>	Supply Voltage	1.8	5.5	V
V <sub>CNTRL</sub>	Control Input Voltage	0	5.5	V
V <sub>SW</sub>	Switch Input Voltage	0	5.5	V
T <sub>A</sub>	Operating Temperature	-40	85	°C

# DIO3712

High-bandwidth and Low on-resistance Analog switch

## DC Electrical Characteristics

All typical value are at  $T_A = 25^\circ\text{C}$ , unless otherwise specified

Symbol	Parameter	Conditions	Temp.	Min.	Typ.	Max.	Unit
$V_{IH}$	Input voltage high	$V_{CC}=5.0\text{V}$	-40 to $85^\circ\text{C}$	1.9			V
		$V_{CC}=3.0\text{V}$		1.3			
$V_{IL}$	Input voltage low	$V_{CC}=5.0\text{V}$	-40 to $85^\circ\text{C}$			0.9	V
		$V_{CC}=3.0\text{V}$				0.6	
$I_{IN}$	Control input leakage	$V_{CC}=1.8\text{V}$ to $5.5\text{V}$ , $V_{IN}=0\text{V}$ or $5.5\text{V}$ or $3.6\text{V}$	-40 to $85^\circ\text{C}$			1	$\mu\text{A}$
$I_{NC(OFF)}$ $I_{NO(OFF)}$	Source off leakage current	$V_{CC}=1.8\text{V}$ to $5.5\text{V}$ , $V_{NO}$ or $V_{NC}=1.0\text{V}$ , $4.5\text{V}$ , $V_{COM}=4.5\text{V}$ , $1.0\text{V}$ , See Figure 3	-40 to $85^\circ\text{C}$			2	$\mu\text{A}$
$I_{NC(ON)}$ $I_{NO(ON)}$ $I_{COM(ON)}$	On leakage current	$V_{CC}=1.8\text{V}$ to $5.5\text{V}$ , $V_{NO}$ or $V_{NC}=1.0\text{V}$ , $4.5\text{V}$ , $V_{COM}=1.0\text{V}$ , $4.5\text{V}$ , or floating	-40 to $85^\circ\text{C}$			2	$\mu\text{A}$
$R_{ON}$	Switch on Resistance	$V_{CC}=2.7\text{V}$ , $V_{NO}$ or $V_{NC}=1.2\text{V}$ , $I_{COM}=-10\text{mA}$ , See Figure 2	$25^\circ\text{C}$		12		$\Omega$
			-40 to $85^\circ\text{C}$			15	
		$V_{CC}=4.5\text{V}$ , $V_{NO}$ or $V_{NC}=3.5\text{V}$ , $I_{COM}=-10\text{mA}$ , See Figure 2	$25^\circ\text{C}$		4.5		$\Omega$
			-40 to $85^\circ\text{C}$			5.0	
$\Delta R_{ON}$	On Resistance Matching between Channels	$V_{CC}=2.7\text{V}$ , $V_{NO}$ or $V_{NC}=1.5\text{V}$ , $I_{COM}=-10\text{mA}$	$25^\circ\text{C}$			0.3	$\Omega$
			-40 to $85^\circ\text{C}$			0.8	
		$V_{CC}=4.5\text{V}$ , $V_{NO}$ or $V_{NC}=3.5\text{V}$ , $I_{COM}=-10\text{mA}$	$25^\circ\text{C}$			0.2	$\Omega$
			-40 to $85^\circ\text{C}$			0.8	
$R_{FLT(ON)}$	On Resistance Flatness	$V_{CC}=2.7\text{V}$ , $V_{NO}$ or $V_{NC}=1.0\text{V}$ , $1.5\text{V}$ , $2.0\text{V}$ , $I_{COM}=-10\text{mA}$	-40 to $85^\circ\text{C}$		5.0		$\Omega$
		$V_{CC}=4.5\text{V}$ , $V_{NO}$ or $V_{NC}=1.0\text{V}$ , $2.0\text{V}$ , $3.5\text{V}$ , $I_{COM}=-10\text{mA}$	-40 to $85^\circ\text{C}$		1.6		
$I_{CC}$	Power Supply Current	$V_{CC}=1.8\text{V}$ to $5.5\text{V}$ , $V_{IN}=0\text{V}$ or $V_{CC}$	-40 to $85^\circ\text{C}$			5	$\mu\text{A}$

# DIO3712

High-bandwidth and Low on-resistance Analog switch

## AC Electrical Characteristics

All typical value are at  $V_{CC}=1.8$  to  $5.5V$ ,  $T_A=25^{\circ}C$  unless otherwise specified

Symbol	Parameter	Conditions	Temp.	Min.	Typ.	Max.	Unit
$T_{ON}$	Turn-On Time	$V_{NO}$ or $V_{NC}=1.5V, R_L = 300\Omega$ , $C_L = 35pF$ , See Figure 9	$25^{\circ}C$			23	ns
$T_{OFF}$	Turn-Off Time	$V_{NO}$ or $V_{NC}=1.5V, R_L = 300\Omega$ , $C_L = 35pF$ , See Figure 9	$25^{\circ}C$			20	ns
$T_{bbm}$	Break-Before -Make Time	$V_{NO1}$ or $V_{NC1} = V_{NO2}$ or $V_{NC2} = 1.5V$ , $R_L = 300\Omega$ , $C_L = 35pF$ , See Figure 8	$25^{\circ}C$			6	ns
OIRR	Off Isolation	$R_L = 50\Omega$ , Signal=0dBm $C_L = 5pF$ See Figure 7	f=10MHz	$25^{\circ}C$		-57	dB
			f=1MHz	$25^{\circ}C$		-75	
Xtalk	Crosstalk	$R_L = 50\Omega$ , Signal=0dBm, $C_L = 5pF$ See Figure 6	f=10MHz	$25^{\circ}C$		-96	dB
			f=1MHz	$25^{\circ}C$		-100	
BW	-3dB bandwidth	$R_L = 50\Omega$ , Signal=0dBm, $C_L = 5pF$ , See Figure 5	$25^{\circ}C$		300		MHz

## AC Electrical Characteristics(continued)

All typical value are for  $V_{CC} = 3.3V$  at  $25^{\circ}C$  unless otherwise specified

Symbol	Parameter	Conditions	Temp.	Min.	Typ.	Max.	Unit
$C_{ON}$	On Capacitance, See Figure 4	f=1MHz	$25^{\circ}C$		10		pF

Test Diagrams

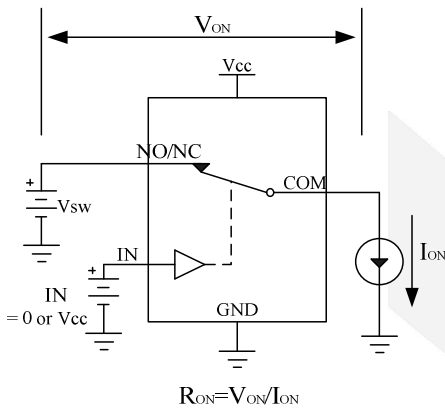

Figure 2 Switch on resistor

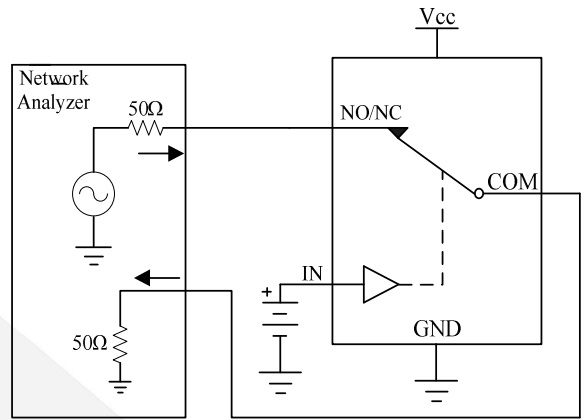

Figure 5 Bandwidth

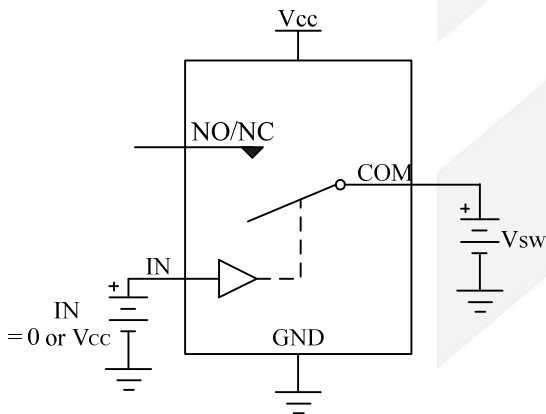

Figure 3 Switch Off Leakage

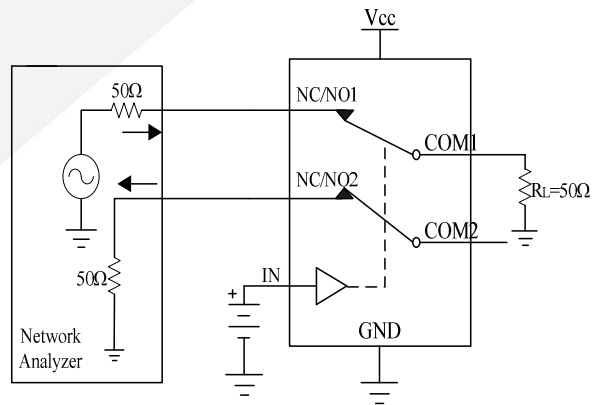

Figure 6 Channel-to-channel crosstalk

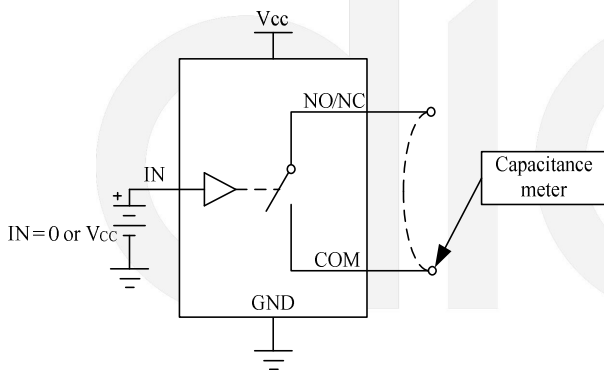

Figure 4 On/off Capacitance test

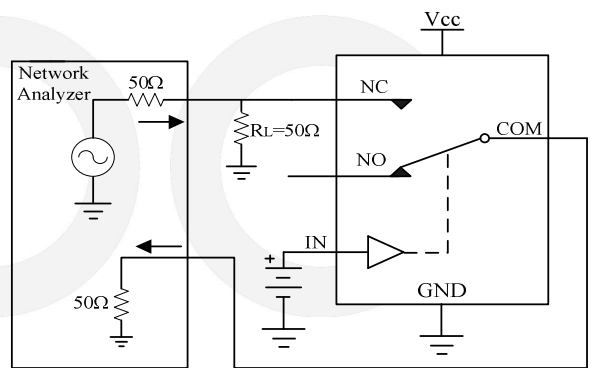

Figure 7 Off-isolation

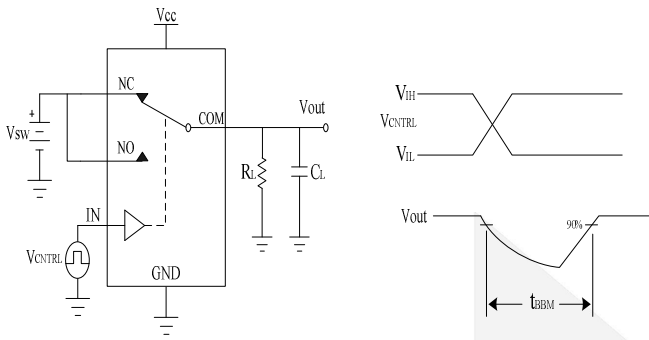

Figure 8 Break-Before-Make

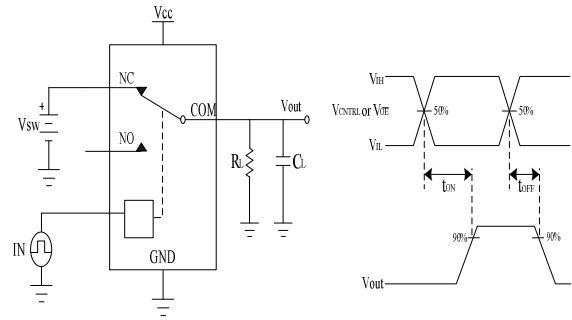

Figure 9 Turn-On/Turn-Off

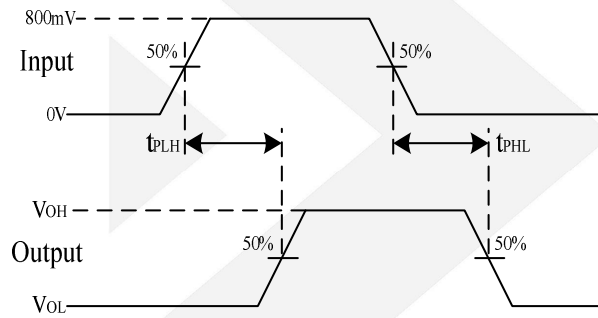

Figure 10 Propagation delay



# DIO3712

High-bandwidth and Low on-resistance Analog switch

## Physical Dimensions: DQFN-10

PIN 1 DOT  
BY MARKING

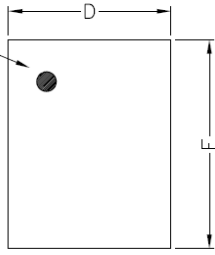

TOP VIEW

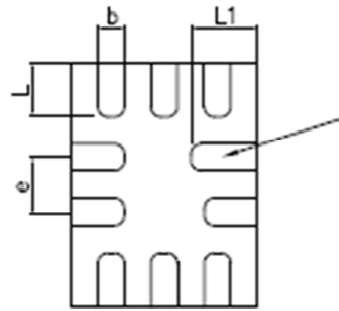

BOTTOM VIEW

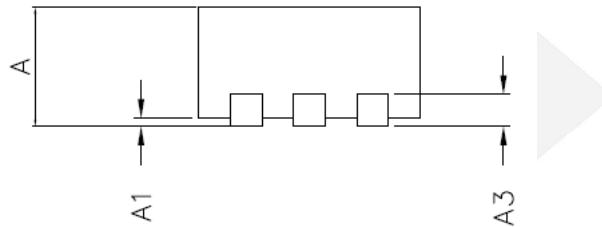

COMMON DIMENSIONS(MM)			
PKG.	UT:ULTRA THIN		
REF.	MIN.	NOM	MAX
A	0.5	0.55	0.6
A1	0		0.05
A3	0.15REF.		
D	1.35	1.4	1.45
E	1.75	1.8	1.85
b	0.15	0.2	0.25
L	0.3	0.4	0.5
L1	0.4	0.5	0.6
e	0.4BSC		



# DIO3712

High-bandwidth and Low on-resistance Analog switch

## Physical Dimensions: MSOP-10

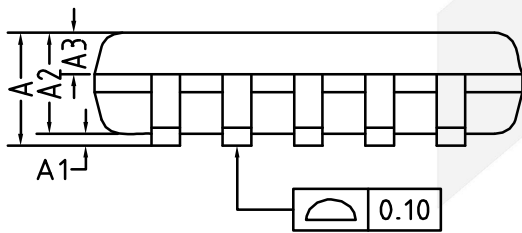
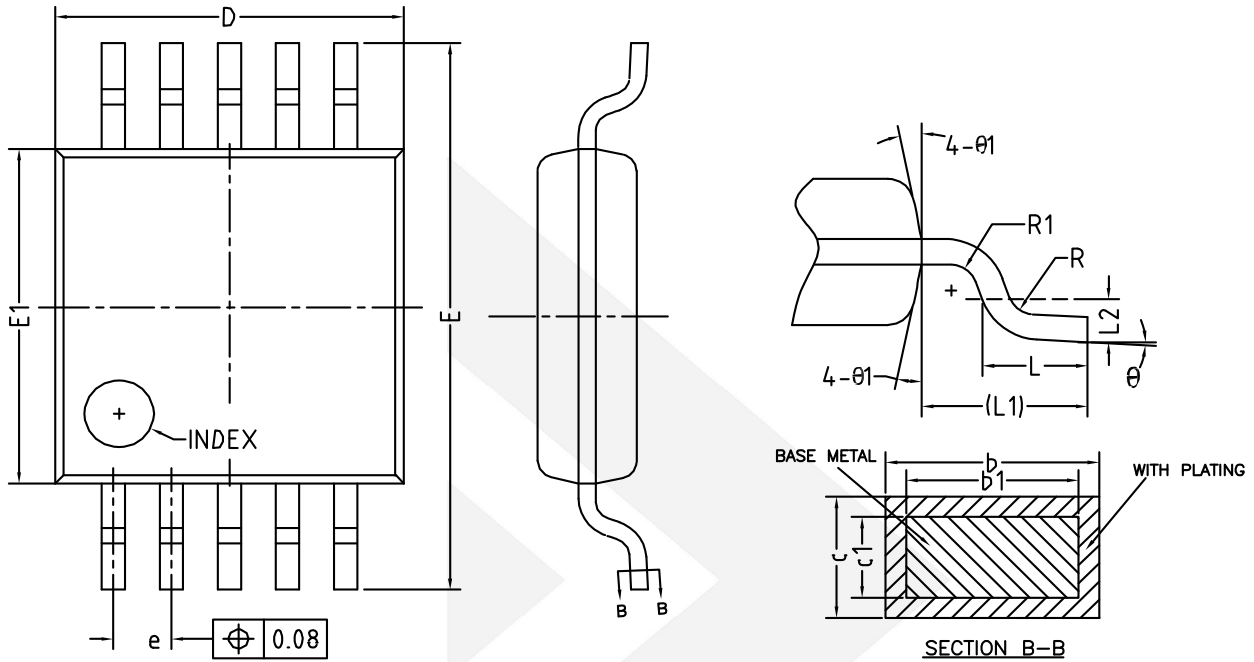

COMMON DIMENSIONS (UNITS OF MEASURE=MILLIMETER)			
Symbol	MIN	NOM	MAX
A	-	-	1.10
A1	0	-	0.15
A2	0.75	0.85	0.95
A3	0.25	0.35	0.39
b	0.18	-	0.27
b1	0.17	0.20	0.23
c	0.15	-	0.20
c1	0.14	0.15	0.16
D	2.90	3.00	3.10
E	4.70	4.90	5.10
E1	2.90	3.00	3.10
e	0.40	0.50	0.60
L	0.45	0.60	0.80
L1	0.95REF		
L2	0.25BSC		
R	0.07	-	-
R1	0.07	-	-
Ø	0°	-	8°
Ø1	9°	12°	15°

## CONTACT US

**D**ioo is a professional design and sales corporation for high-quality and performance analog semiconductors. The company focuses on industry markets, such as, cell phone, handheld products, laptop, and medical equipment and so on. Dioo's product families include analog signal processing and amplifying, LED drivers and charger IC. Go to <http://www.dioo.com> for a complete list of Dioo product families.

For additional product information, or full datasheet, please contact with our Sales Department or Representatives.



## X-ON Electronics

Largest Supplier of Electrical and Electronic Components

*Click to view similar products for [Analogue Switch ICs](#) category:*

*Click to view products by [Dioo](#) manufacturer:*

Other Similar products are found below :

[FSA3051TMX](#) [NLAS4684FCTCG](#) [NLAS5223BLMNR2G](#) [NLVAS4599DTT1G](#) [NLX2G66DMUTCG](#) [425541DB](#) [425528R](#) [099044FB](#)  
[NLAS5123MNR2G](#) [PI5A4157CEX](#) [PI5A4599BCEX](#) [NLAS4717EPFCT1G](#) [PI5A3167CCEX](#) [SLAS3158MNR2G](#) [PI5A392AQE](#)  
[PI5A4157ZUEX](#) [PI5A3166TAEX](#) [FSA634UCX](#) [TC4066BP\(N,F\)](#) [DG302BDJ-E3](#) [PI5A100QEX](#) [HV2605FG-G](#) [HV2301FG-G](#)  
[RS2117YUTQK10](#) [RS2118YUTQK10](#) [RS2227XUTQK10](#) [ADG452BRZ-REEL7](#) [MAX4066ESD+](#) [MAX391CPE+](#) [MAX4730EXT+T](#)  
[MAX314CPE+](#) [BU4066BCFV-E2](#) [MAX313CPE+](#) [BU4S66G2-TR](#) [NLAS3158MNR2G](#) [NLASB3157MTR2G](#) [TS3A4751PWR](#)  
[NLAS4157DFT2G](#) [NLAS4599DFT2G](#) [NLASB3157DFT2G](#) [NLAST4599DFT2G](#) [NLAST4599DTT1G](#) [DG300BDJ-E3](#) [DG2503DB-T2-GE1](#)  
[DG2502DB-T2-GE1](#) [TC4W53FU\(TE12L,F\)](#) [74HC2G66DC.125](#) [ADG619BRMZ-REEL](#) [ADG1611BRUZ-REEL7](#) [LTC201ACN#PBF](#)