

# DIO6605B

## 5V Output, High-Efficiency 1.2MHz, Synchronous Step-Up Converter

### Features

- High-Efficiency Synchronous-Mode
- 2.7-4.5V input voltage range
- Device Quiescent Current: 30 $\mu$ A(TYP)
- Less than 1 $\mu$ A Shutdown Current with 5V or 0V output voltage
- Output Voltage Fixed 5V
- Power-Save Mode for Improved Efficiency at Low Output Power
- 1.8V Logic on EN Pin for Control
- Low Reverse Leakage Current when  $V_{OUT} > V_{IN}$
- Thermal shutdown
- Green package: DFN2\*3-8 is pin compatible.
- -40°C to +85°C Operating Temperature Range

### Descriptions

The DIO6605B is a 5V output, high efficiency boost regulator targeted for general step-up applications. It can be used for generating 5V at 600mA from a 3.3V rail or a Li-ion battery.

High switching frequency minimizes the sizes of inductor and capacitor. Integrated power MOSFETs and internal compensation make the DIO6605B simple to use and fit the total solution into a compact space.

For light load current, the DIO6605B enters into the power-save mode to maintain high efficiency. Anti-ringing control circuitry reduces EMI concerns by damping the inductor in discontinuous mode. The DIO6605B provides true output disconnect and this allows  $V_{OUT}$  to go to zero volts during shutdown without drawing any current from the input source. The DIO6605B supports 1.8V logic for control.

### Applications

- Single Cell Li-Battery Powered Products
- Portable Audio Players
- Cellular Phones
- Personal Medical Products

### Typical Application

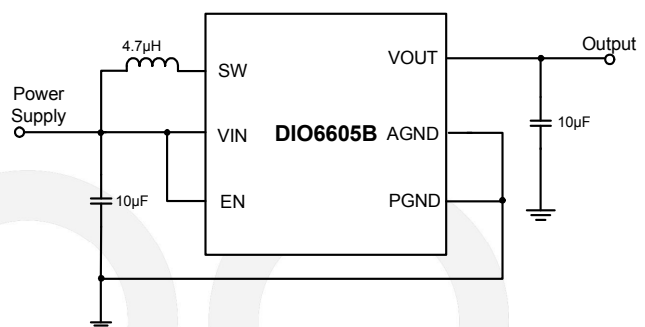

### Ordering Information

Order Part Number	Top Marking		T <sub>A</sub>	Package	
DIO6605BFN8	D6605	Green	-40 to +85°C	DFN2*3-8	Tape & Reel, 3000

## Pin Assignments

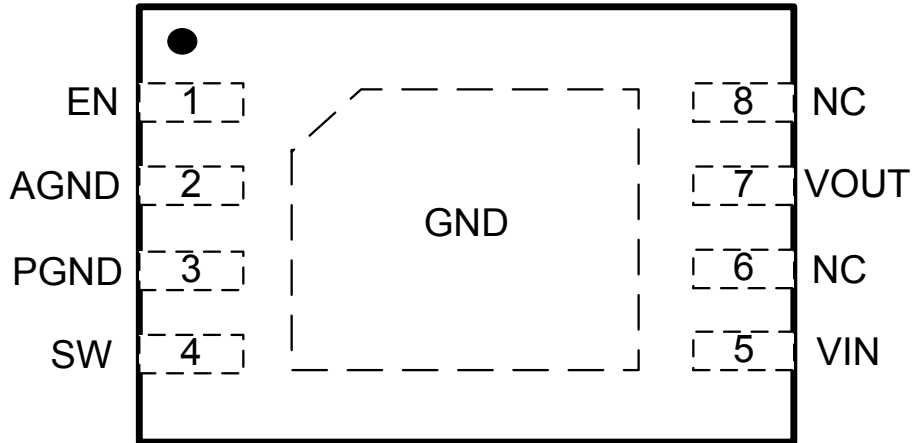

DFN2\*3-8

Figure 1 Pin Assignment (Top View)

## Pin Definitions

Pin Name	Description
EN	Enable control. Pull high to turn on. Do not float.
AGND	Analog Ground.
PGND	Power Ground.
SW	Boost and Rectifying Switch Input.
VIN	Boost Converter Supply Voltage.
VOUT	Boost Converter Output.
NC	No Connect



# DIO6605B

5V Output, High-Efficiency 1.2MHz, Synchronous Step Up Converter

## Absolute Maximum Ratings

Stresses beyond those listed under "Absolute Maximum Rating" may cause permanent damage to the device. These are stress ratings only and functional operation of the device at these or any other condition beyond those indicated in the operational sections of the specifications is not implied. Exposure to absolute maxim rating conditions for extended periods may affect device reliability.

Parameter	Rating	Unit
Input Voltage Range on SW, VOUT, VIN, EN	-0.3 to 6	V
Operating Temperature Range.	-40 to +85	°C
Junction Temperature	150	°C
Package Thermal Resistance DFN2*3-8, $\theta_{JA}$	60	°C/W
Storage Temperature	-65 to +150	°C
Lead Temperature (soldering, 10s)	260	°C
ESD Susceptibility	HBM	4000
	MM	200

## Recommend Operating Conditions

The Recommended Operating Conditions table defines the conditions for actual device operation. Recommended Operating conditions are specified to ensure optimal performance to the datasheet specifications. DIOO does not Recommend exceeding them or designing to Absolute Maximum Ratings.

Parameter	Rating	Unit
Supply Voltage	2.7 to 4.5	V
Junction Temperature Range	-40 to 125	°C
Ambient Temperature Range	-40 to 85	°C



## DIO6605B

### Electrical Characteristics

$T_A=25^{\circ}\text{C}$ ,  $V_{\text{OUT}}=5\text{V}$ ,  $V_{\text{IN}}=3.6\text{V}$ ,  $C_{\text{IN}}=C_{\text{OUT}}=10\mu\text{F}$ ,  $L=4.7\mu\text{H}$ , unless otherwise specified.

Symbol	Parameter	Test Conditions	Min	Typ	Max	Unit
$V_{\text{OUT}}$	Output voltage range		4.8	5	5.2	V
$V_{\text{IN}}$	Input voltage range		2.7		4.5	
f	Oscillator frequency		870	1200	1470	kHz
$I_{\text{SW}}$	Switch current limit		0.8	1.2	1.6	A
	Start-up current limit			600		mA
	Boost switch-on resistance	$V_{\text{OUT}}=5\text{V}$		400		m $\Omega$
	Rectifying switch-on resistance	$V_{\text{OUT}}=5\text{V}$		530		m $\Omega$
	Output voltage accuracy	$V_{\text{IN}}=2.7\text{V}$ , $I_{\text{O}}=10\text{mA}$			3.8	%
	Line regulation	$V_{\text{IN}}=3.0\text{V}$ to $V_{\text{OUT}}-0.7\text{V}$ , $I_{\text{O}}=100\text{mA}$		0.8	1	%
	Load regulation			0.5		%
	Quiescent current	$V_{\text{EN}}=V_{\text{IN}}=2.7\text{V}$ , $I_{\text{O}}=0$ , $V_{\text{OUT}}=5\text{V}$		30	55	$\mu\text{A}$
	Shutdown current	$V_{\text{EN}}=0\text{V}$ , $V_{\text{IN}}=2.7\text{V}$			1	$\mu\text{A}$
$V_{\text{IL}}$	EN input low voltage				0.4	V
$V_{\text{IH}}$	EN input high voltage		1.6			V
	EN input current	Clamped on GND			1	$\mu\text{A}$
	Over temperature protection			150		$^{\circ}\text{C}$
	Over temperature hysteresis			15		$^{\circ}\text{C}$

5V Output, High-Efficiency 1.2MHz, Synchronous Step Up Converter

### Typical Application

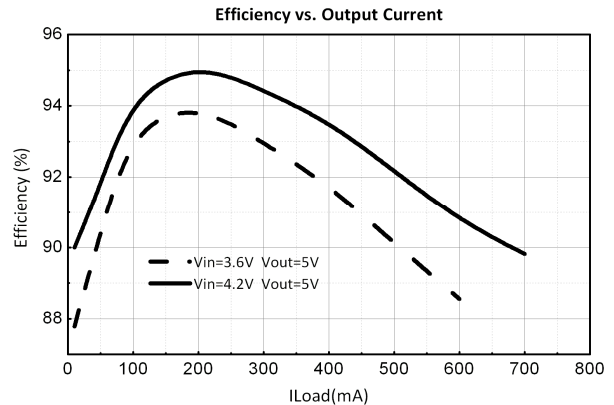
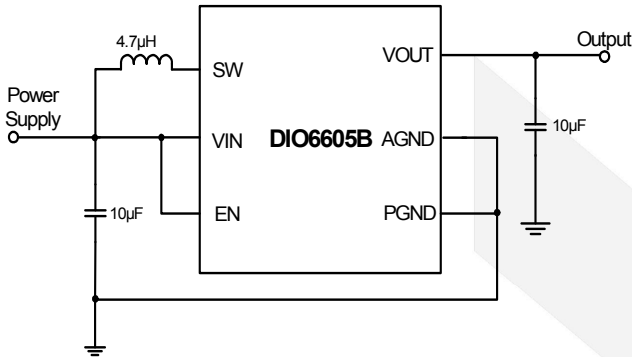

### Application Information

#### Inductor Selection

A boost converter normally requires two main passive components for storing energy during the conversion. A boost inductor and a storage capacitor at the output are required. To select the boost inductor, it is recommended to keep the possible peak inductor current below the current limit threshold of the power switch in the chosen configuration. The highest peak current through the inductor and the switch depends on the output load, the input ( $V_{IN}$ ), and the output voltage ( $V_{OUT}$ ). Estimation of the maximum average inductor current is done using Equation 2:

$$I_L = I_O \times \frac{V_{OUT}}{V_{IN} \times 0.8} \quad (2)$$

For example, for an output current of 75mA at 5V, at least an average current of 170mA flows through the inductor at a minimum input voltage of 2.7V.

The second parameter for choosing the inductor is the desired current ripple in the inductor. Normally, it is advisable to work with a ripple of less than 20% of the average inductor current. A smaller ripple reduces the magnetic hysteresis losses in the inductor, as well as output voltage ripple and EMI. But in the same way, regulation time rises at load changes. In addition, a larger inductor increases the total system costs. With these parameters, it is possible to calculate the value for the inductor by using Equation 3:

$$L = \frac{V_{IN} \times (V_{OUT} - V_{IN})}{\Delta I_L \times f \times V_{OUT}} \quad (3)$$

Parameter  $f$  is the switching frequency and  $\Delta I_L$  is the ripple current in the inductor. In typical applications, a 4.7µH inductance is recommended. The device has been optimized to operate with inductance values between 1µH and 10µH. Nevertheless, operation with higher inductance values may be possible in some applications. Detailed stability analysis is then recommended. Care must be taken because load transients and losses in the circuit can lead to higher currents as estimated in Equation 3. Also, the losses in the inductor which include magnetic hysteresis losses and copper losses are a major parameter for total circuit efficiency.

**Input Capacitor**

At least a 10 $\mu$ F input capacitor is recommended to improve transient behavior of the regulator and EMI behavior of the total power supply circuit. A ceramic capacitor or a tantalum capacitor with a 100nF ceramic capacitor in parallel, placed close to the IC, is recommended.

**Output Capacitor**

The major parameter necessary to define the output capacitor is the maximum allowed output voltage ripple of the converter. This ripple is determined by two parameters of the capacitor, the capacitance and the ESR. It is possible to calculate the minimum capacitance needed for the defined ripple, supposing that the ESR is zero, by using Equation 4:

$$C_{MIN} = \frac{I_O \times (V_{OUT} - V_{IN})}{f \times \Delta V \times V_{OUT}} \quad (4)$$

Parameter  $f$  is the switching frequency and  $\Delta V$  is the maximum allowed ripple. With a chosen ripple voltage of 10mV, a minimum capacitance of 4.5 $\mu$ F is needed. In this value range, ceramic capacitors are a good choice. The ESR and the additional ripple created are negligible. It is calculated using Equation 5:

$$\Delta V_{ESR} = I_O \times R_{ESR} \quad (5)$$

The total ripple is the sum of the ripple caused by the capacitance and the ripple caused by the ESR of the capacitor. Additional ripple is caused by load transients. This means that the output capacitor has to completely supply the load during the charging phase of the inductor.

The value of the output capacitance depends on the speed of the load transients and the load current during the load change. With the calculated minimum value of 4.5 $\mu$ F and load transient considerations, the recommended output capacitance value is in the range of 4.7 $\mu$ F to 22 $\mu$ F.

Care must be taken on capacitance loss caused by deteriorating due to the applied DC voltage and the frequency characteristic of the capacitor. For example, larger form factor capacitors (in 1206 size) have their self resonant frequencies in the same frequency range as the DIO6605B operating frequency. So the effective capacitance of the capacitors used may be significantly lower. Therefore, the recommendation is to use smaller capacitors in parallel instead of one larger capacitor.

**Layout Considerations**

As for all switching power supplies, the layout is an important step in the design, especially at high-peak currents and high switching frequencies. If the layout is not carefully done, the regulator could show stability problems as well as EMI problems. Therefore, use wide and short traces for the main current path and for the power ground tracks. The input capacitor, output capacitor, and the inductor should be placed as close as possible to the IC. Use a common ground node for power ground and a different one for control ground to minimize the effects of ground noise. Connect these ground nodes at any place close to the ground pin of the IC.

The feedback divider should be placed as close as possible to the ground pin of the IC. To lay out the control ground, it is recommended to use short traces as well, separated from the power ground traces. This avoids ground shift problems, which can occur due to superimposition of power ground current and control ground current.



## DIO6605B

### Thermal Information

Implementation of integrated circuits in low-profile and fine-pitch surface-mount packages typically requires special attention to power dissipation. Many system-dependent issues such as thermal coupling, airflow, added heat sinks and convection surfaces, and the presence of other heat-generating components affect the power-dissipation limits of a given component.

Three basic approaches for enhancing thermal performance follow.

- 1 Improving the power dissipation capability of the PCB design.
- 2 Improving the thermal coupling of the component to the PCB.
- 3 Introducing airflow in the system.

5V Output, High-Efficiency 1.2MHz, Synchronous Step Up Converter



# DIO6605B

5V Output, High-Efficiency 1.2MHz, Synchronous Step Up Converter

## Typical Performance Characteristics

$T_A=25^{\circ}\text{C}$ ,  $V_{\text{OUT}}=5\text{V}$ ,  $V_{\text{IN}}=3.6\text{V}$ ,  $C_{\text{IN}}=C_{\text{OUT}}=10\mu\text{F}$ ,  $L=4.7\mu\text{H}$ , unless otherwise specified.

### Start up from Vin

(Rload=8.2 ohm)

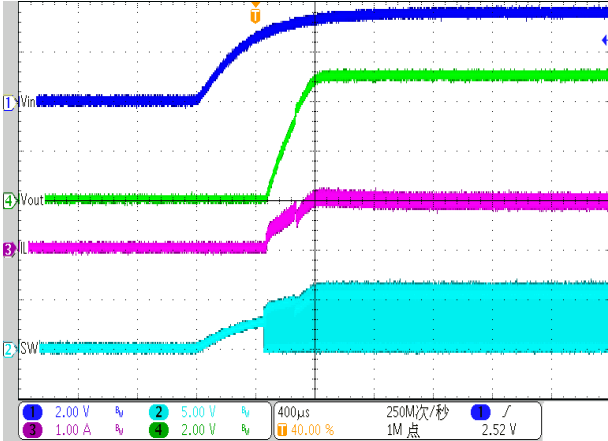

### Shut down from Enable

(Rload=8.2 ohm)

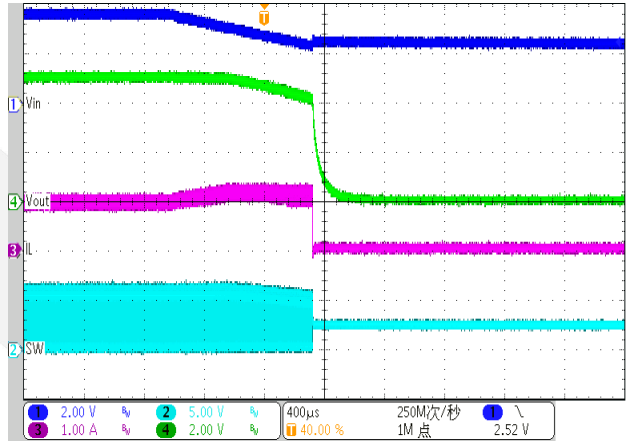

### Start up from Enable

(Rload=8.2 ohm)

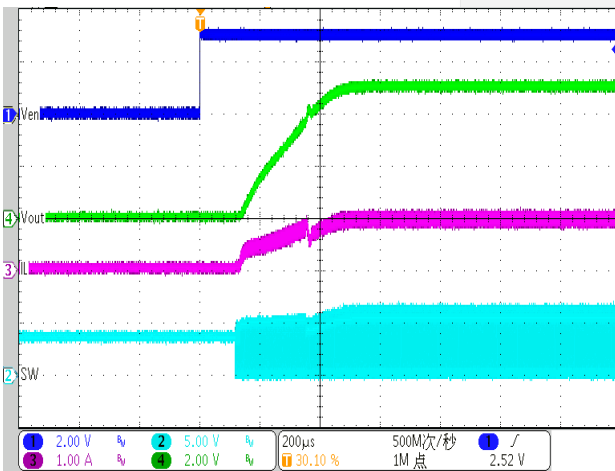

### Shut down from Enable

(Rload=8.2ohm)

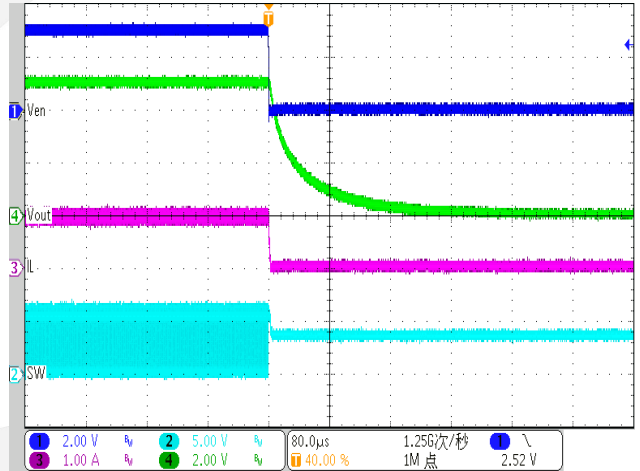



**Load transient**

(Iload=0.05A~0.6A)

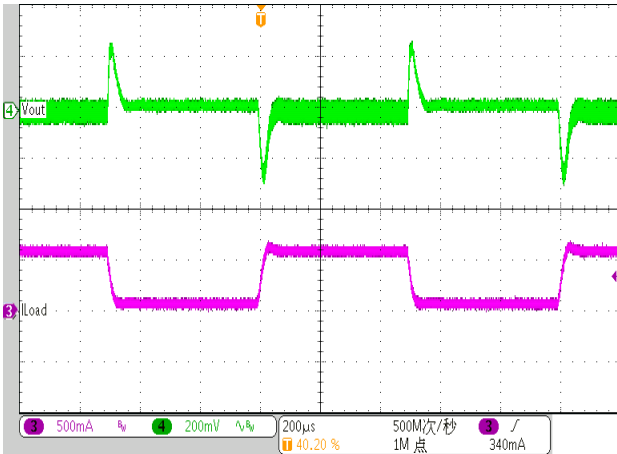

**Load transient**

(Iload=0.3~0.6A)

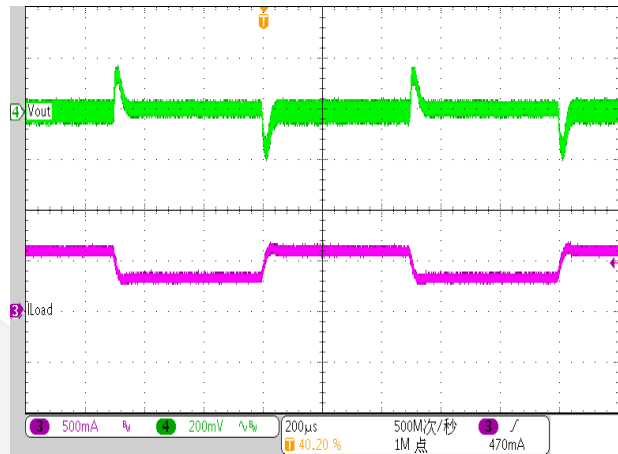

**Ripple**

(Iload=0 A)

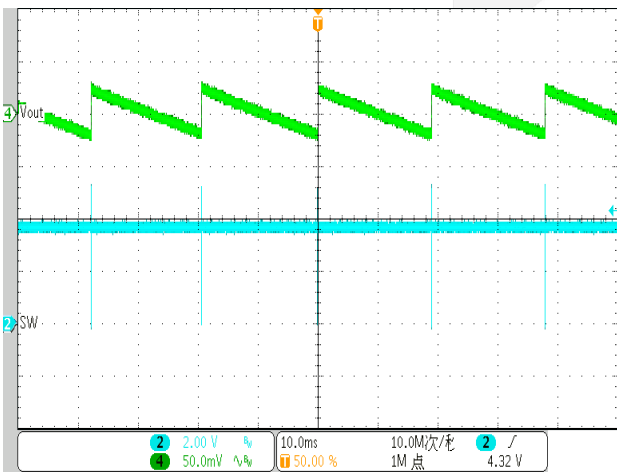

**Ripple**

(Iload=0.6 A)

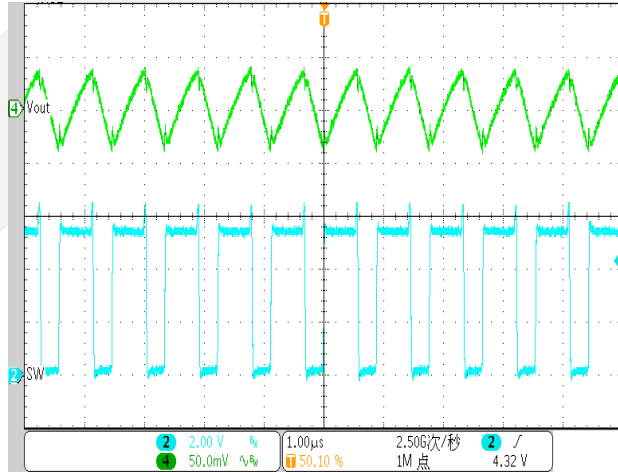

**Short Circuit Protection**

(Rload=0 ohm)

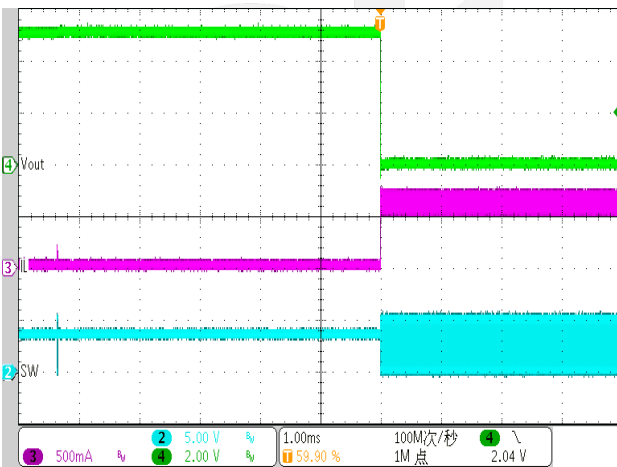

**Short Circuit Recovery**

(Rload=0 ohm)

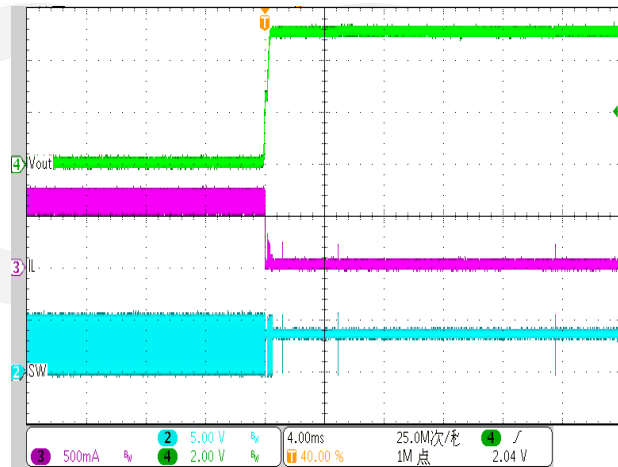



# DIO6605B

5V Output, High-Efficiency 1.2MHz, Synchronous Step Up Converter

## Physical Dimensions: DFN2\*3-8

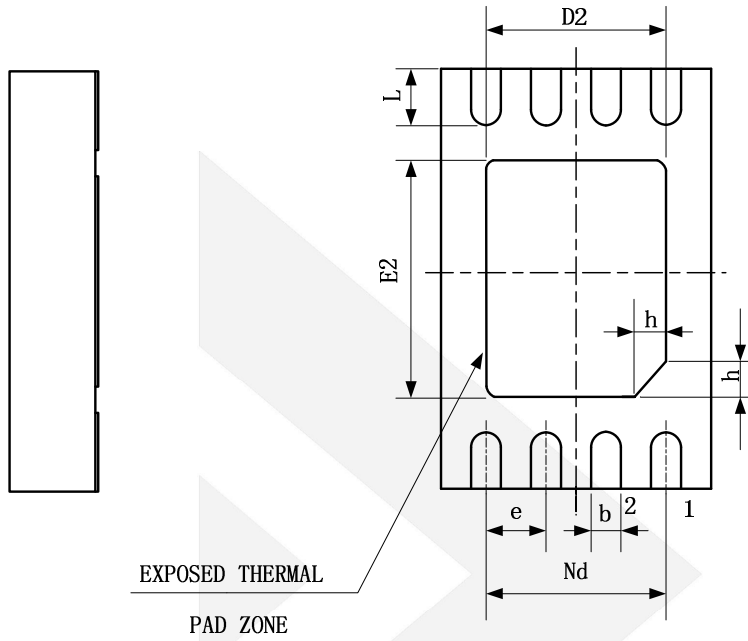

BOTTOM VIEW

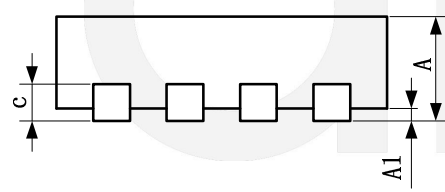
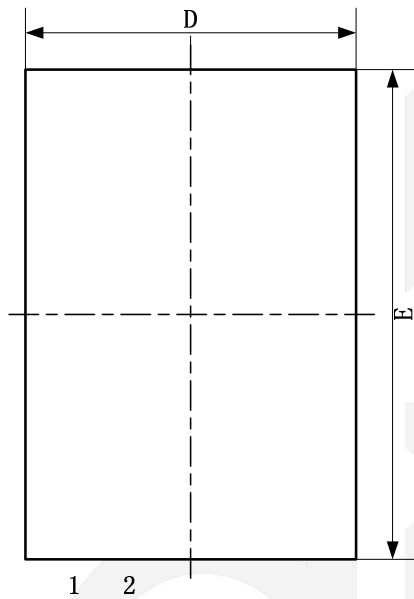

COMMON DIMENSIONS (UNITS OF MEASURE=MILLIMETER)			
Symbol	MIN	NOM	MAX
A	0.70	0.75	0.80
A1	0	0.02	0.05
b	0.18	0.25	0.30
c	0.18	0.20	0.25
D	1.90	2.00	2.10
D2	1.40	1.50	1.60
e	0.50BSC		
Nd	1.50BSC		
E	2.90	3.00	3.10
E2	1.50	1.60	1.70
L	0.30	0.40	0.50
h	0.20	0.25	0.30



## DIO6605B

5V Output, High-Efficiency 1.2MHz, Synchronous Step Up Converter

### CONTACT US

Dioo is a professional design and sales corporation for high-quality and performance analog semiconductors. The company focuses on industry markets, such as, cell phone, handheld products, laptop, and medical equipment and so on. Dioo's product families include analog signal processing and amplifying, LED drivers and charger IC. Go to <http://www.dioo.com> for a complete list of Dioo product families.

For additional product information, or full datasheet, please contact with our Sales Department or Representatives.

dioo

## X-ON Electronics

Largest Supplier of Electrical and Electronic Components

*Click to view similar products for [Switching Voltage Regulators](#) category:*

*Click to view products by [Dioo](#) manufacturer:*

Other Similar products are found below :

[FAN53610AUC33X](#) [FAN53611AUC123X](#) [FAN48610BUC33X](#) [FAN48610BUC45X](#) [FAN48617UC50X](#) [R3](#) [430464BB](#) [KE177614](#)  
[FAN53611AUC12X](#) [MAX809TTR](#) [NCV891234MW50R2G](#) [NCP81103MNTXG](#) [NCP81203PMNTXG](#) [NCP81208MNTXG](#)  
[NCP81109GMNTXG](#) [SCY1751FCCT1G](#) [NCP81109JMNTXG](#) [AP3409ADNTR-G1](#) [NCP81241MNTXG](#) [LTM8064IY](#) [LT8315EFE#TRPBF](#)  
[LTM4664EY#PBF](#) [LTM4668AIY#PBF](#) [NCV1077CSTBT3G](#) [XCL207A123CR-G](#) [MPM54304GMN-0002](#) [MPM54304GMN-0004](#)  
[MPM54304GMN-0003](#) [AP62300Z6-7](#) [MP8757GL-P](#) [MIC23356YFT-TR](#) [LD8116CGL](#) [HG2269M/TR](#) [OB2269](#) [XD3526](#) [U6215A](#) [U6215B](#)  
[U6620S](#) [LTC3412IFE](#) [LT1425IS](#) [MAX25203BATJA/VY+](#) [MAX77874CEWM+](#) [XC9236D08CER-G](#) [MP3416GJ-P](#) [MP5461GC-Z](#)  
[MPQ4590GS-Z](#) [MAX38640BENT18+T](#) [MAX77511AEWB+](#) [MAX20406AFOD/VY+](#) [MAX20408AFOC/VY+](#)