



DIO8242C

Adaptive 100/120Hz Current Ripple Remover Max Input Current $\leq 60\text{mA}$

Features

- Regulator for adaptive 100/120Hz current ripple remove
- Built-in zener diode for input voltage clamping
- Built-in 100V power MOSFET
- Programmable amplitude LED current ripple
- Programmable maximum cathode voltage of LED
- Programmable maximum LED current
- Optimized for TRIAC dimming, 1% brightness without flicker
- The current ripple is less than $\pm 1\%$
- SOT23-3, SOT89-3 packages

Descriptions

DIO8242C is a regulator for driving internal NMOSFET to remove the 100/120Hz LED string current ripple on AC/DC power.

Patented control strategies are optimized for remover current ripple. Nover circuit design makes a lower BOM and high cost-effective for flickerless filament.

Applications

- LED lighting

Ordering Information

Order Part Number	Top Marking		T _A	Package	
DIO8242CST3	1014	Green	-40 to 125°C	SOT23-3	Tape & Reel,3000
DIO8242CTC3	1014	Green	-40 to 125°C	SOT89-3	Tape & Reel,2500



DIO8242C

Adaptive 100/120Hz Current Ripple Remover Max Input Current $\leq 60\text{mA}$

Pin Assignment

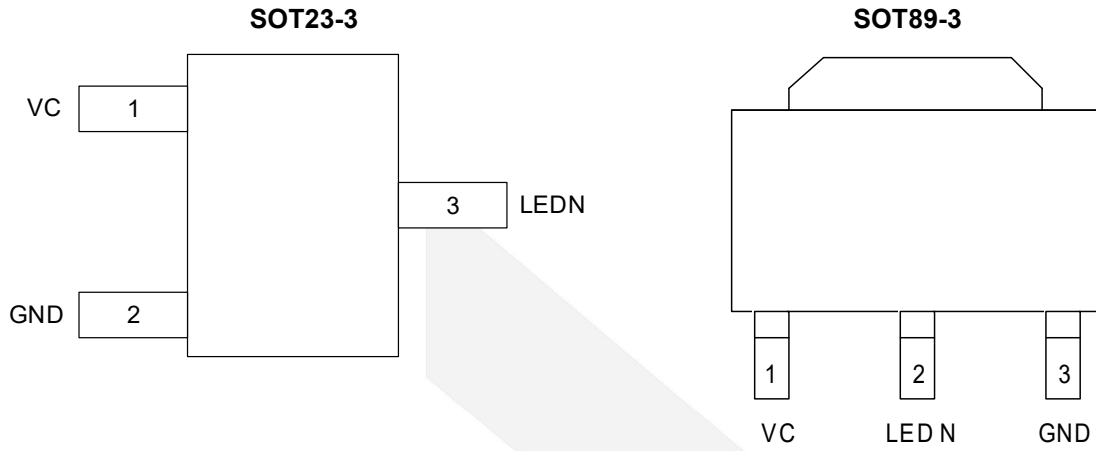

Figure 1 Top View

Pin Descriptions

Name	Description
GND	Power Ground
VC	LED Current Ripple Programming
LEDN	Connect to the Cathode of LED string





DIO8242C

Adaptive 100/120Hz Current Ripple Remover Max Input Current ≤ 60mA

Absolute Maximum Ratings

Stresses beyond those listed under “Absolute Maximum Rating” may cause permanent damage to the device. These are stress ratings only and functional operation of the device at these or any other condition beyond those indicated in the operational sections of the specifications is not implied. Exposure to absolute maximum rating conditions for extended periods may affect device reliability.

Parameter		Rating	Unit
LEDN		100	V
VC		-0.3 to 6	V
Junction Temperature		150	°C
Lead Temperature		260	°C
Storage Temperature		-65 to 150	°C
Thermal Resistance / θ_{JA}	SOT23-3	220	°C/W
	SOT89-3	80	
Thermal Resistance / θ_{JC}	SOT23-3	130	°C/W
	SOT89-3	25	

Recommend Operating Conditions

The Recommended Operating Conditions table defines the conditions for actual device operation. Recommended Operating conditions are specified to ensure optimal performance to the datasheet specifications. DIOO does not Recommend exceeding them or designing to Absolute Maximum Ratings.

Parameter		Rating	Unit
LEDN		< 100	V
Junction Temperature (T_J)		125	°C
Under point VLEDN		0.8~1.2	V
Power consumption	SOT23-3	< 250	mW
	SOT89-3	< 650	



DIO8242C

Adaptive 100/120Hz Current Ripple Remover Max Input Current ≤ 60mA

Electrical Characteristics

Typical value: $V_{CC}=3.6V$, $T_A = 25^{\circ}C$, unless otherwise specified.

Symbol	Parameter	Conditions	Min.	Typ.	Max.	Unit
I_{ST}	Start-up Current				1	μA
V_{REF}	LEDN Compare Voltage			15		V
I_{CLMT}	LED Current Limit				60	mA
R_{DSON}	MOS Rdson			16		Ω
BV	Breakdown Voltage		100			V

Specifications subject to change without notice.

Typical Performance Characteristics

$C_{VC}=1\mu F$, $C_{EC}=8.2\mu F$, unless otherwise specified.

LED Current Ripple without DIO8242C
($V_{AC}=220V, V_{LED}=250V, I_{LED}=15mA$)

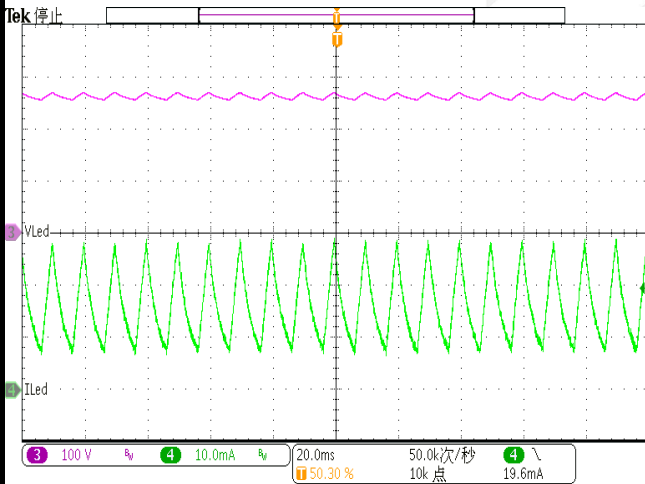

LED Current Ripple with DIO8242C
($V_{AC}=220V, V_{LED}=250V, I_{LED}=15mA$)

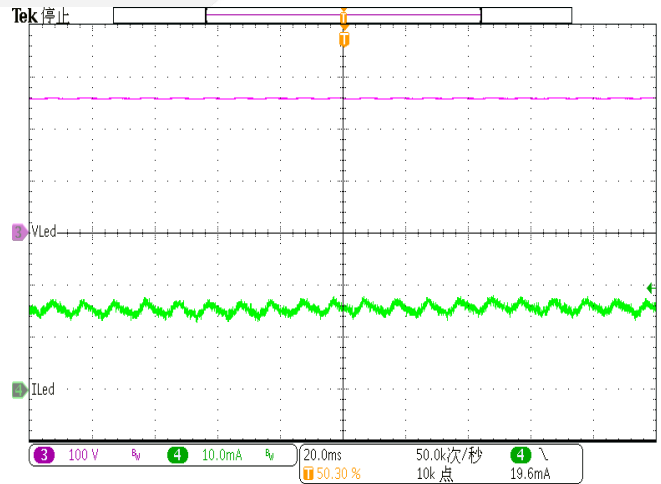

AC Source Power ON
($V_{AC}=120V, V_{LED}=125V, I_{LED}=15mA$)

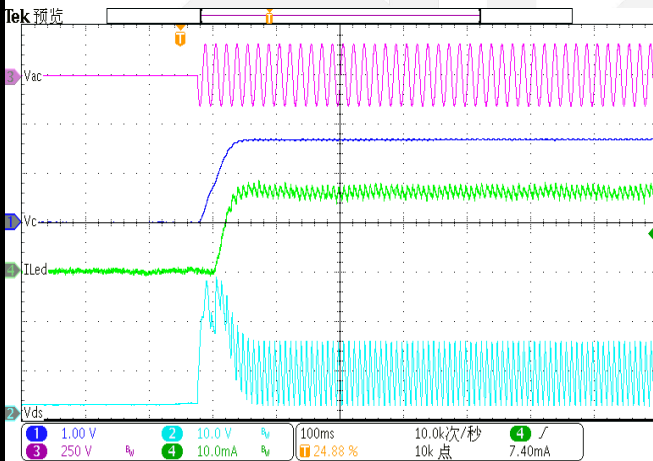

AC Source Power OFF
($V_{AC}=120V, V_{LED}=125V, I_{LED}=15mA$)

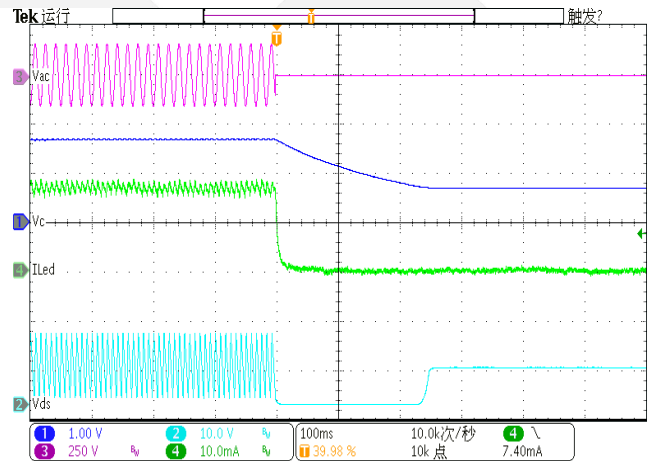

Block Diagram

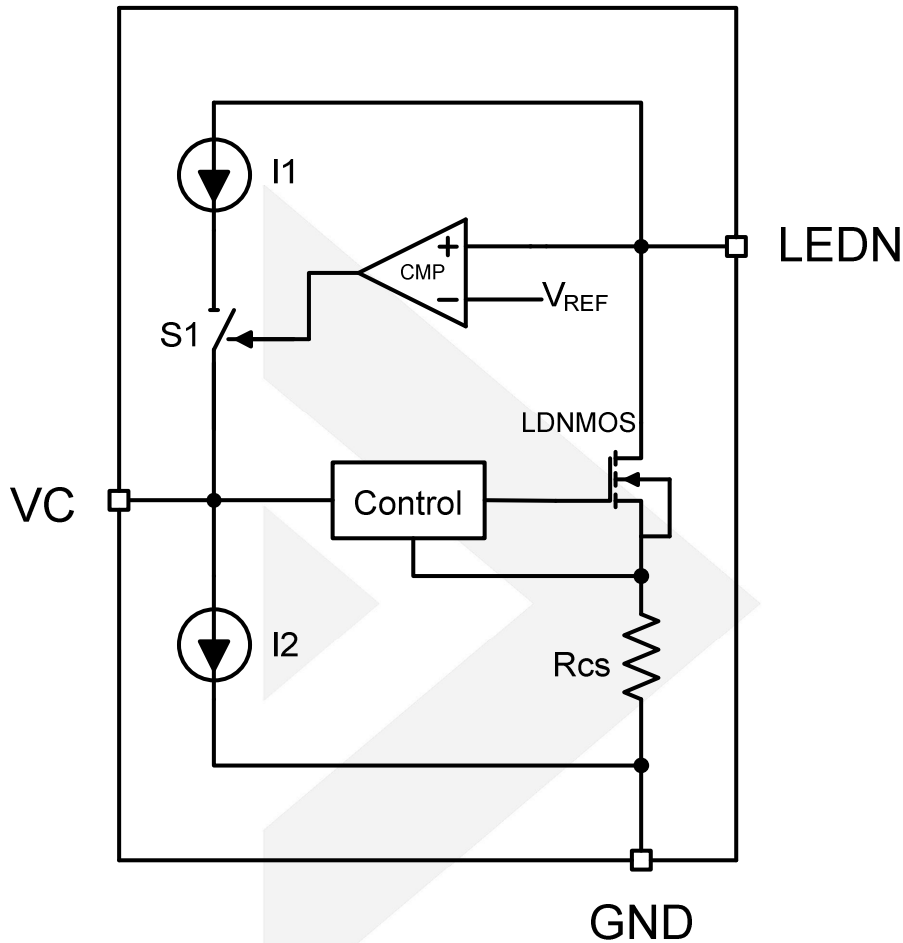

Function Description

DIO8242C is designed for driving one LED string and removing the 100/120Hz LED current ripple.

Theory of Operation

The LED string and DIO8242C are both supplied by an AC/DC current source. The drain of internal NMOSFET is connected to the cathode of LED string. A sensing resistor R_{cs} is connected between the source of NMOSFET and GND. DIO8242C drives NMOSFET to transfer the LED current ripple to voltage ripple on NMOSFET, and ensures the constant voltage across LED string and the constant current flow through LED string. The scalable adaptive function of DIO8242C can regulate the cathode voltage of LED string to minimum to improve the efficiency of the system.

Current Ripple Removing

The capacitor C_c between VC and GND is an integral capacitor. DIO8242C transform the voltage on C_c to a reference voltage. The current regulator regulates LED current via negative feedback control.

C_c should be large enough in order to remove the current ripple of the LED string. However, too large capacitor may slow down the dynamic response.

Adaptive Regulation

DIO8242C controls the voltage on C_C by monitoring the operation state of built-in N-MOSFET. The efficiency of system is relatively low when N-MOSFET always works in the saturation region. DIO8242C detects it and charges C_C to raise the V_{VC} and I_{LED} , then the output voltage of power supply is reduced, and the voltage drop on N-MOSFET decreases.

Conversely, when N-MOSFET is working in the linear region, LED current regulation loop is open. DIO8242C detects it and discharges C_C to reduce the V_{VC} and I_{LED} , then the output voltage of power supply is raised, and the LED current regulation loop is closed.

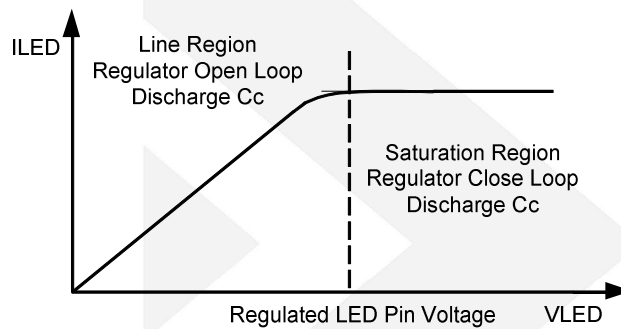

PCB Design Guideline

1. DIO8242C should be placed far away from the power devices for better thermal performance.
2. The area of LED current loop should be as small as possible.

Application Information

DIO8242C design guide:

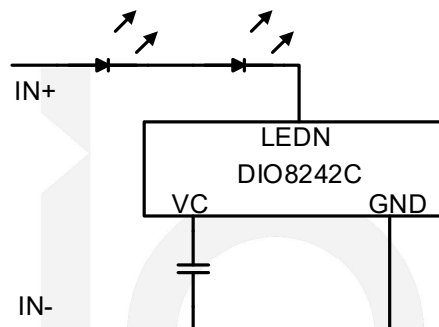

1. The value of the capacitor between VC and GND can determine the final amplitude of the current ripple. It should be large enough in order to remove the current ripple of the LED string. However, too large capacitor may low down the dynamic response.

Physical Dimensions: SOT23-3

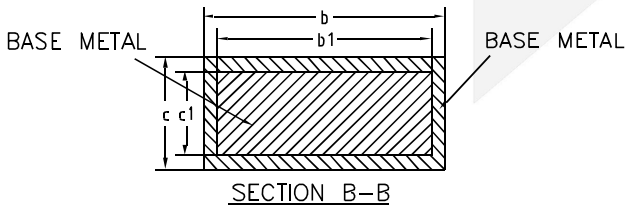
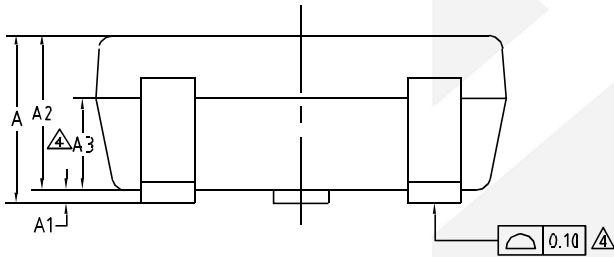
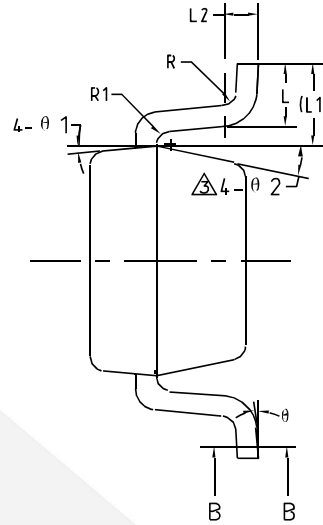
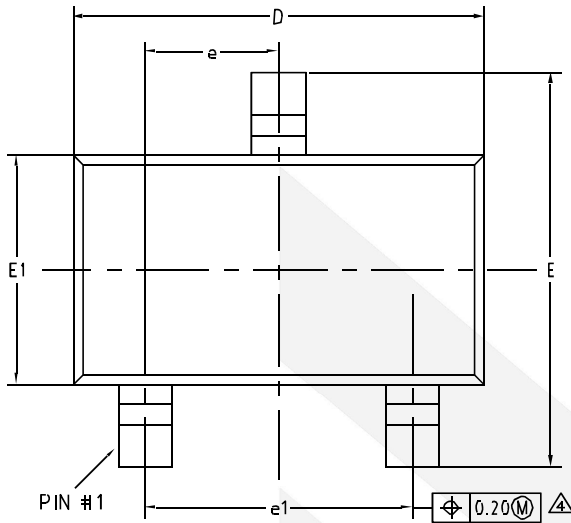

COMMON DIMENSIONS (UNITS OF MEASURE=MILLIMETER)			
Symbol	MIN	NOM	MAX
A	-	-	1.25
A1	0	-	0.15
A2	1.00	1.10	1.20
A3	0.60	0.65	0.70
b	0.36	-	0.50
b1	0.36	0.38	0.45
c	0.14	-	0.20
c1	0.14	0.15	0.16
D	2.826	2.926	3.026
E	2.60	2.80	3.00
E1	1.526	1.626	1.726
e	0.90	0.95	1.00
e1	1.80	1.90	2.00
L	0.35	0.45	0.60
L1	0.59REF		
L2	0.25BSC		
R	0.05	-	-
R1	0.05	-	0.20
θ	0°	-	8°
θ1	3°	5°	7°
θ2	6°	-	14°

Adaptive 100/120Hz Current Ripple Remover Max Input Current ≤ 60mA

Physical Dimensions: SOT89-3

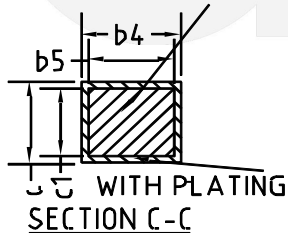
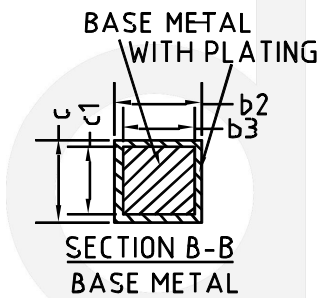
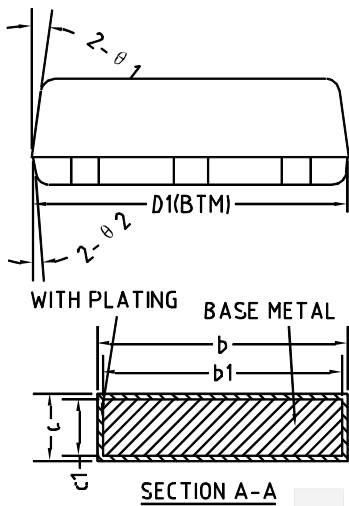
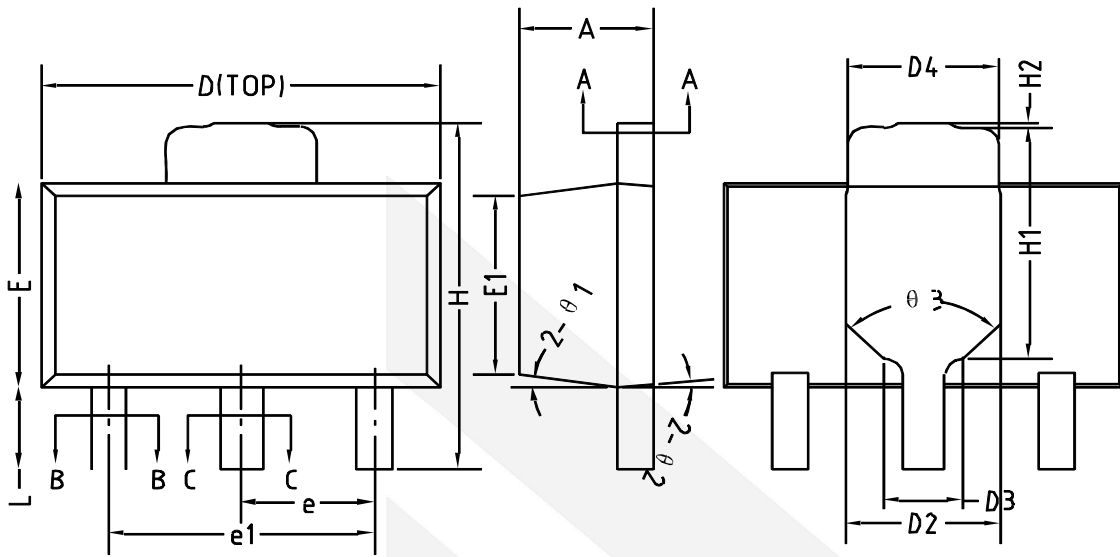

Symbol	Min.	NOM.	Max.
A	1.40	1.50	1.60
b	1.68	-	1.77
b1	1.67	1.70	1.73
b2	0.38	-	0.47
b3	0.37	0.40	0.43
b4	0.46	-	0.55
b5	0.45	0.48	0.51
c	0.40	-	0.44
c1	0.39	0.40	0.41
D	4.40	4.50	4.60
D1	4.35	4.45	4.55
D2	1.60	1.75	1.90
D3	0.75	0.90	1.05
D4	1.60	1.70	1.80
E	2.40	2.50	2.60
E1	2.13	-	2.19
e	1.50BSC		
e1	3.00BSC		
H	4.05	-	4.25
H1	2.70	-	3.00
H2	0	-	0.10
L	0.89	-	1.20
θ1	6°	8°	10°
θ2	3°	5°	7°
θ3	85°	90°	95°

Adaptive 100/120Hz Current Ripple Remover Max Input Current ≤ 60mA



DIO8242C

Adaptive 100/120Hz Current Ripple Remover Max Input Current $\leq 60\text{mA}$

CONTACT US

Dioo is a professional design and sales corporation for high-quality and performance analog semiconductors. The company focuses on industry markets, such as, cell phone, handheld products, laptop, and medical equipment and so on. Dioo's product families include analog signal processing and amplifying, LED drivers and charger IC. Go to <http://www.dioo.com> for a complete list of Dioo product families.

For additional product information, or full datasheet, please contact with our Sales Department or Representatives.

dioo

X-ON Electronics

Largest Supplier of Electrical and Electronic Components

Click to view similar products for [LED Display Drivers](#) category:

Click to view products by [Dioo](#) manufacturer:

Other Similar products are found below :

[STP16DP05PTR](#) [MP3370GN-Z](#) [ISL97631IHTZ-T7A](#) [ISL97632IRT26Z-T](#) [LV5026MC-AH](#) [IK62083DWT](#) [OB3655TAP-H](#) [OB3399PAP](#)
[AW36514FCR](#) [AW36428FCR](#) [KAQW214A TL](#) [TM1629\(TA2009B\)](#) [WS2814F](#) [XB402U-L27](#) [HT16K33A-20SOP](#) [HT16D33A-28SSOP](#)
[TM1628E](#) [TM512AE0](#) [TM512AD](#) [TM0822B](#) [SY7310AADC](#) [SY58863FAC](#) [SY5863AJAC](#) [FM4115K.](#) [TM1638N-SOP28-TA1319B](#)
[SPL5013CNI-TRG](#) [AW21024QNR](#) [AW36423FCR](#) [AW36515FCR](#) [AW99703CSR](#) [AW21036QNR](#) [AW21009QNR](#) [AW20108QNR](#)
[AW2016AQNR](#) [AW9967DNR](#) [AW9106CQNR](#) [PT4115BE89E](#) [CC1109](#) [SD6800BCTR](#) [SDH7612DH](#) [HT16D35A-48LQFP-EP](#) [HT1635C-](#)
[64LQFP-7*7](#) [HT16K33A-28SOP](#) [HT16D31A-16NSOP-EP](#) [TLD5099EP](#) [BCR 431U](#) [IS32FL3740-ZLA3-TR](#) [OB3379ZCPA-D](#)
[NCL31001MNITWG](#) [NCV78702MW0AR2G](#)