

# DIO8850D

## Single Stage Buck PFC Controller for LED Lighting

### Features

- Valley turn-on of the MOSFET to achieve low switching losses
- 0.3V current sense reference voltage leads to a lower sense resistance thus a lower conduction loss
- Low start up current: 15 $\mu$ A typical
- Reliable short LED and Open LED protection
- Power factor >0.9
- Compact package: SOT23-6, SOIC-8

### Descriptions

The DIO8850D is a single stage Buck PFC controller targeting at LED lighting applications. It drives the Buck converter in the quasi-resonant mode to achieve higher efficiency.

It keeps the Buck converter inconstant on time operation to achieve high power factor.

### Applications

- LED Lighting
- Down light
- Tube lamp & PAR lamp & Bulb lamp

### Block Diagram

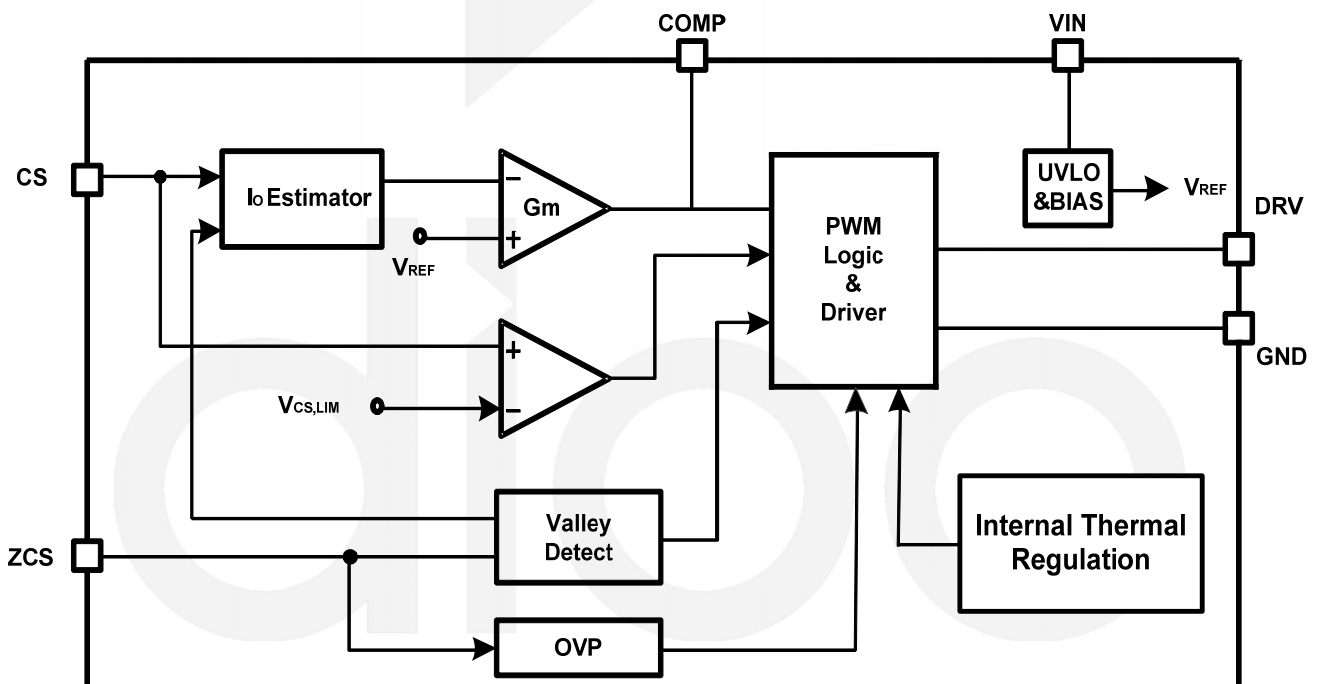

Figure1 Block Diagram

## Ordering Information

Order Part Number	Top Marking		T <sub>A</sub>	Package	
DIO8850DCST6	YW8D	Green	-40 to +125°C	SOT23-6	Tape & Reel, 3000
DIO8850DCS8	DIO8850D	Green	-40 to +125°C	SOIC-8	Tape & Reel, 2500

## Pin Assignments

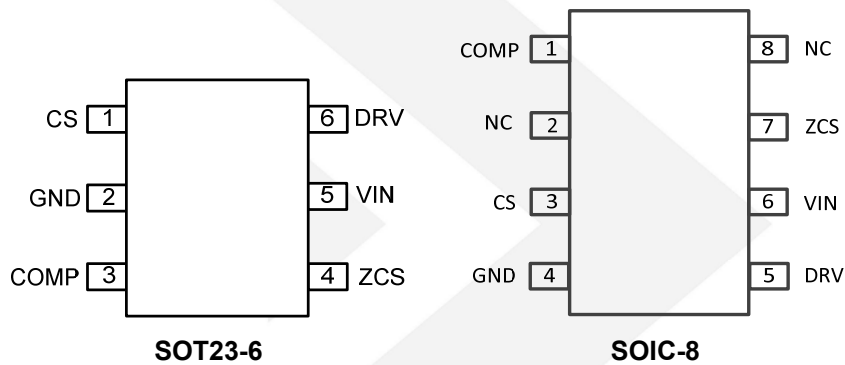

Figure 2 Pin Assignment (Top View)

## Pin Definitions

Pin Name	Description
CS	Current sense pin. Connect this pin to the source of the primary switch. Connect the sense resistor across the source of the primary switch and the GND pin.  (current sense resistor Resistor: $R_s = \frac{1}{2} \times \frac{V_{ref}}{I_{out}}$ )  Also this pin used to detect transformer and secondary is short or not.
GND	Ground pin
COMP	Loop compensation pin. Connect a RC network across this pin and ground to stabilize the control loop.
ZCS	Inductor current zero-crossing detection pin. This pin receives the auxiliary winding voltage by a resistor divider and detects the inductor current zero crossing point. This pin also provides over voltage protection and line regulation modification function simultaneously. If the voltage on this pin is above $V_{ZCS,OV}$ , the IC would enter overvoltage protection mode. Good line regulation can be achieved by adjusting the upper resistor of the divider.
VIN	Power supply pin. This pin also provides output over voltage protection along with ZCS pin.
DRV	Gate driver pin. Connect this pin to the gate of primary MOSFET.
NC	Not Connect.

## Absolute Maximum Ratings

Stresses beyond those listed under “Absolute Maximum Rating” may cause permanent damage to the device. These are stress ratings only and functional operation of the device at these or any other condition beyond those indicated in the operational sections of the specifications is not implied. Exposure to absolute maximum rating conditions for extended periods may affect device reliability.

Parameter		Rating	Unit
VIN, DRV		-0.3 to 19	V
Supply Current I <sub>VIN</sub>		15	mA
ZCS		-0.3 to VIN+0.3	V
CS, COMP		-0.3 to 5	V
Power Dissipation, P <sub>D</sub> @ T <sub>A</sub> = 25°C, SOT23-6		0.6	W
Package Thermal Resistance, SOT23-6	θ <sub>JA</sub>	170	°C/W
	θ <sub>JC</sub>	130	
Power Dissipation, P <sub>D</sub> @ T <sub>A</sub> = 25°C, SOIC-8		1.1	W
Package Thermal Resistance, SOIC-8	θ <sub>JA</sub>	100	°C/W
	θ <sub>JC</sub>	50	
Storage Temperature Range		-65 to 150	°C
Junction Temperature Range		150	°C
Lead Temperature Range		260	°C
ESD	HBM, JEDEC: JESD22-A114	2000	V
	MM, JEDEC: JESD22-A115	200	

## Recommend Operating Conditions

The Recommended Operating Conditions table defines the conditions for actual device operation. Recommended Operating conditions are specified to ensure optimal performance to the datasheet specifications. DIOO does not Recommend exceeding them or designing to Absolute Maximum Ratings.

Parameter	Rating	Unit
Supply Voltage	9.5 to 15.4	V
Ambient Temperature Range	-40 to 125	°C



# DIO8850D

Single Stage Buck PFC Controller For LED Lighting

## Electrical Characteristics

$V_{IN} = 12V$ ,  $T_A = 25^\circ C$ , unless otherwise specified.

Symbol	Parameter	Test Conditions	Min	Typ	Max	Unit
$V_{VIN,ON}$	VIN turn-on threshold			16		V
$V_{VIN,OFF}$	VIN turn-off threshold			7.3		V
$V_{VIN,OVP}$	VIN OVP voltage			17.8		V
$I_{ST}$	Start up Current	$V_{VIN} < V_{VIN,OFF}$		15		$\mu A$
$I_{VIN,OVP}$	Shunt current in OVP mode	After $V_{VIN} > V_{VIN,OVP}$ , then set $V_{IN}=15V$		1.75		mA
$I_Q$	Quiescent Current	No switching		0.26		mA
$I_{VIN}$	Operation current	$C_L=100pF, f=15kHz$		0.36		mA
<b>Error Amplifier Section</b>						
$V_{REF}$	Internal reference voltage		0.294	0.3	0.306	V
<b>ZCS pin Section</b>						
$V_{ZCS\_OVP}$	ZCS pin OVP voltage threshold			1.5		V
$V_{FAST\_ST}$	Fast start up threshold			0.55		V
<b>Current Sense Section(Source PIN of integrated MOSFET)</b>						
$V_{CS\_LMT}$	Current limit reference voltage			0.75		V
$K_2$	CC Feed forward coefficient			0.1		
$R_{K2}$	CC Feed forward resistor $R_{K2}$			1020		$\Omega$
<b>PWM Section</b>						
$T_{ON,MAX}$	Max on time	COMP high clamp		27.15		$\mu s$
$T_{LEB}$	Leading edge blanking time			350		ns
$T_{OFF,MAX}$	Max OFF time			68		$\mu s$
$T_{LEB,ZCD}$	ZCD Blanking Time	After turn off		2		$\mu s$
$f_{MAX}$	Maximum switching frequency			115		kHz
<b>Gate Driver</b>						
$V_{GATE\_CLAMP}$	Output Clamp Voltage	$V_{CC}=20V$		12		V
$T_{RISING}$	rising time from 10% to 90%	$C_{LOAD}=1nF$		210		ns
$T_{FALLING}$	falling time from 90% to 10%	$C_{LOAD}=1nF$		40		ns
<b>Thermal Section</b>						
TSD	Thermal Shutdown Temperature			150		$^\circ C$

## Typical Application

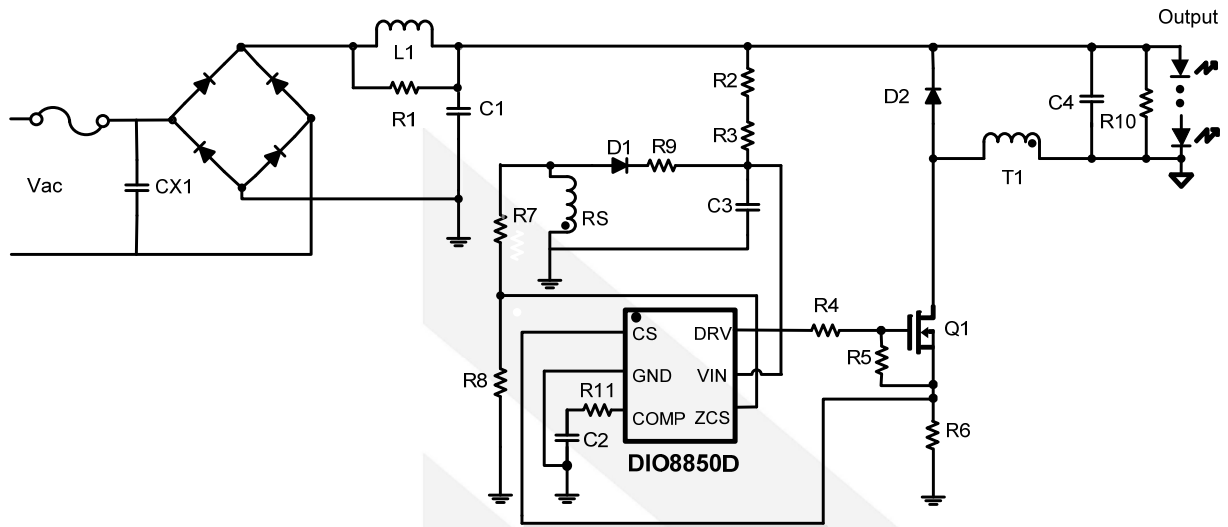

Figure 3 Typical Application

## Application Information

### Start up

After AC or DC supply is powered on, the capacitor  $C_{VIN}$  across VIN and GND pin is charged up by BUS voltage through a start up resistor  $R_{ST}$ . Once  $V_{VIN}$  rises up to  $V_{VIN-ON}$ , the internal blocks start to work and PWM output is enabled.

### Shut down

After AC supply or DC BUS is powered off, the energy stored in the BUS capacitor will be discharged. When the auxiliary winding of transformer can't supply enough energy to VIN pin,  $V_{VIN}$  will drop down. Once  $V_{VIN}$  is below  $V_{VIN-OFF}$ , the IC will stop working and  $V_{COMP}$  will be discharged to zero.

### Quasi-Resonant Operation

QR mode operation provides low turn-on switching losses for Buck converter.

### Over Voltage Protection (OVP) & Open LED Protection (OLP)

The output voltage is reflected by the auxiliary winding voltage of the transformer, and both ZCS pin and VIN pin provide over voltage protection function. When the load is null or large transient happens, the output voltage will exceed the rated value. When  $V_{VIN}$  exceeds  $V_{VIN,OVP}$  or  $V_{ZCS}$  exceeds  $V_{ZCS,OVP}$ , the over voltage protection is triggered and the IC will discharge  $V_{VIN}$  by an internal current source  $I_{VIN,OVP}$ . Once  $V_{VIN}$  is below  $V_{VIN,OFF}$ , the IC will shut down and be charged again by BUS voltage through start up resistor. If the overvoltage condition still

exists, the system will operate in hiccup mode.

### Short Circuit Protection (SCP)

When the output is shorted, the output voltage is clamped to zero. The voltage of the auxiliary winding is proportional to the output winding, so  $V_{VIN}$  will drop down without auxiliary winding supply. Once  $V_{VIN}$  is below  $V_{VIN,OFF}$ , the IC will shut down and be charged again by the BUS voltage through the start up resistor. If the short circuit condition still exists, the system will operate in hiccup mode. In order to guarantee SCP function not effected by voltage spike of auxiliary winding, a filter resistor is needed ( $10\Omega$  typically).



## Physical Dimensions: SOT-23-6

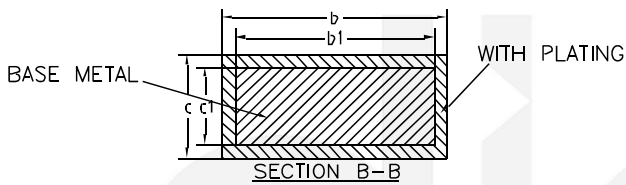
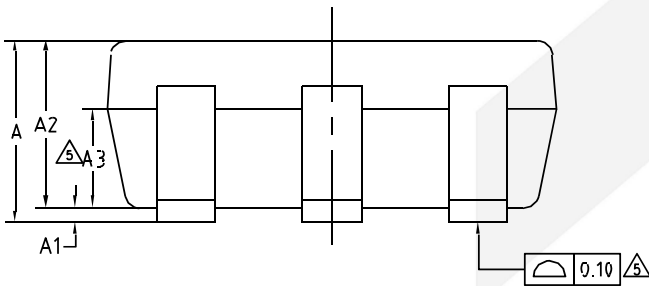
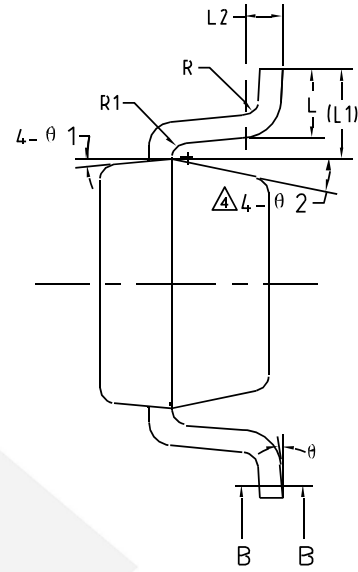
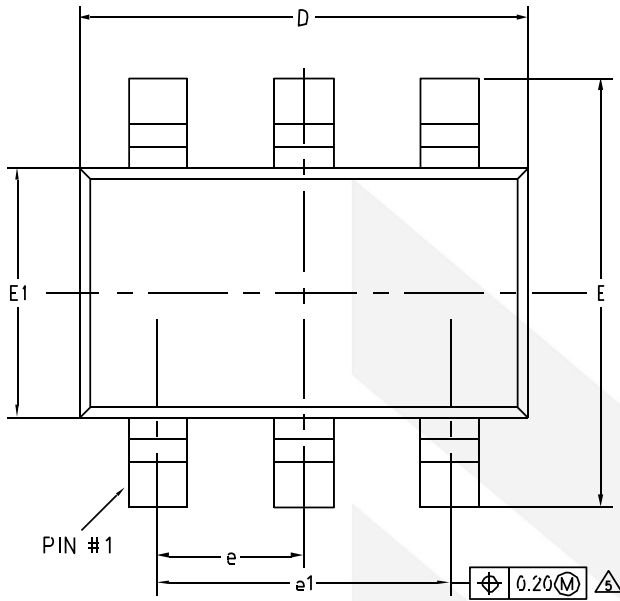

COMMON DIMENSIONS (UNITS OF MEASURE=MILLIMETER)			
Symbol	MIN	NOM	MAX
A	-	-	1.25
A1	0	-	0.15
A2	1.00	1.10	1.20
A3	0.60	0.65	0.70
b	0.36	-	0.50
b1	0.36	0.38	0.45
c	0.14	-	0.20
c1	0.14	0.15	0.16
D	2.826	2.926	3.026
E	2.60	2.80	3.00
E1	1.526	1.626	1.726
e	0.90	0.95	1.00
e1	1.80	1.90	2.00
L	0.35	0.45	0.60
L1	0.59REF		
L2	0.25BSC		
R	0.10	-	-
R1	0.10	-	0.25
θ	0°	-	8°
θ1	3°	5°	7°
θ2	6°	-	14°



## DIO8850D

Single Stage Buck PFC Controller For LED Lighting

### CONTACT US

Dioo is a professional design and sales corporation for high-quality and performance analog semiconductors. The company focuses on industry markets, such as, cell phone, handheld products, laptop, and medical equipment and so on. Dioo's product families include analog signal processing and amplifying, LED drivers and charger IC. Go to <http://www.dioo.com> for a complete list of Dioo product families.

For additional product information, or full datasheet, please contact with our Sales Department or Representatives.





## X-ON Electronics

Largest Supplier of Electrical and Electronic Components

*Click to view similar products for [LED Lighting Drivers](#) category:*

*Click to view products by [Dioo](#) manufacturer:*

Other Similar products are found below :

[LV5235V-MPB-H](#) [MB39C602PNF-G-JNEFE1](#) [MIC2871YMK-T5](#) [AL1676-10BS7-13](#) [AL1676-20AS7-13](#) [AP5726WUG-7](#) [ICL8201](#)  
[IS31BL3228B-UTLS2-TR](#) [IS31BL3506B-TTLS2-TR](#) [AL3157F-7](#) [AP5725FDCG-7](#) [LV52204MTTBG](#) [AP5725WUG-7](#) [STP4CMPQTR](#)  
[NCL30086BDR2G](#) [CAT4004BHU2-GT3](#) [LV52207AXA-VH](#) [AP1694AS-13](#) [TLE4242EJ](#) [KTD2027EWE-TR](#) [AS3688](#) [IS31LT3172-GRLS4-TR](#)  
[TLD2311EL](#) [KTD2694EDQ-TR](#) [KTZ8864EJAA-TR](#) [IS32LT3174-GRLA3-TR](#) [MP2488DN-LF-Z](#) [NLM0010XTSA1](#) [AL1676-20BS7-13](#)  
[ZXLD1370QESTTC](#) [MPQ7220GF-AEC1-P](#) [MPQ4425BGJ-AEC1-P](#) [MPQ7220GF-AEC1-Z](#) [MPQ4425BGJ-AEC1-Z](#) [IS31FL3737B-QFLS4-TR](#)  
[IS31FL3239-QFLS4-TR](#) [KTD2058EUAC-TR](#) [KTD2037EWE-TR](#) [DIO5662ST6](#) [KTD2026BEWE-TR](#) [MAX20052CATC/V+](#)  
[MAX25606AUP/V+](#) [BD6586MUV-E2](#) [BD9206EFV-E2](#) [LYT4227E](#) [LYT6079C-TL](#) [MP3394SGF-P](#) [MP4689AGN-P](#) [MPQ4425AGQB-AEC1-Z](#) [KTD2060EUAC-TR](#)