

Display Elektronik GmbH

DATA SHEET

TFT MODULE

DEM 096096A VMH-PW-N

1,1" TFT

Product Specification

Ver.: 0

10.05.2016

Revision History

Revision	Date	Originator	Detail	Remarks
0	10.05.2016	ZFY	Initial Release	-

Table of Contents

No.	Item	Page
1.	General Description	4
2.	Module Parameter	4
3.	Absolute Maximum Ratings	4
4.	DC Characteristics	5
5.	Backlight Characteristic	5
5.1.	Backlight Characteristics.....	5
5.2.	Backlighting Circuit	5
6.	Optical Characteristics	6
6.1.	Optical Characteristics	6
6.2.	Definition of Response Time	6
6.3.	Definition of Contrast Ratio	7
6.4.	Definition of Viewing Angles.....	7
6.5.	Definition of Color Appearance	8
6.6.	Definition of Surface Luminance, Uniformity and Transmittance.....	8
7.	Block Diagram and Power Supply	9
8.	Interface Pins Definition	10
9.	AC Characteristics	11
9.1.	Serial Interface Characteristics (4-line Serial)	11
10.	Quality Assurance	12
10.1	Purpose	12
10.2	Standard for Quality Test.....	12
10.3	Nonconforming Analysis & Disposition	12
10.4	Agreement Items.....	12
10.5	Standard of the Product Visual Inspection	13
10.6	Inspection Specification	14
10.7	Classification of Defects.....	18
10.8	Identification/marketing criteria	18
10.9	Packaging	18
11.	Reliability Specification	19
12.	Precautions and Warranty	20
12.1	Safety.....	20
12.2	Handling.....	20
12.3	Storage.....	20
12.4	Metal Pin (Apply to Products with Metal Pins).....	20
12.5	Operation	21
12.6	Static Electricity.....	21
12.7	Limited Warranty.....	21
13.	Outline Drawing	22

1. General Description

The specification is a transmissive type color active matrix liquid crystal display (LCD) which uses amorphous thin film transistor (TFT) as switching devices. This product is composed of a TFT-LCD panel, driver IC and a backlight unit.

2. Module Parameter

Features	Details	Unit
Display Size (Diagonal)	1.1"	-
LCD Type	TFT	-
Display Mode	Transmissive / Normally Black	-
Resolution	96 x RGB x 96	Pixels
View Direction	FULL VIEW	Best Image
Module Outline	25.37 x 28.15 x 2.40 (Note1)	mm
Active Area	19.87 x 19.87	mm
Pixel Size	0.207 x 0.207	mm
Pixel Arrangement	RGB Stripe	-
Display Colors	262k	-
Interface	Serial Interface	-
Driver IC	ST7735S (Sitronix)	-
With or without Touch Panel	Without	-
Operating Temperature	-20°C to +70°C	°C
Storage Temperature	-30°C to +80°C	°C
Weight	~ 2	g

Note 1: Exclusive hooks, posts, FFC/FPC tail etc.

3. Absolute Maximum Ratings

$V_{SS}=0V$, $T_a=25^{\circ}C$

Item	Symbol	Min.	Max.	Unit
Supply Voltage	VDD	-0.3	4.6	V
Storage Temperature	T _{stg}	-30	+80	°C
Operating Temperature	T _{op}	-20	+70	°C

Note 1: If T_a below 50°C, the maximal humidity is 90%RH, if T_a over 50°C, absolute humidity should be less than 60%RH.

Note 2: The response time will be extremely slow when the operating temperature is around -10°C, and the back ground will become darker at high temperature operating.

4. DC Characteristics

Item	Symbol	Min.	Typ.	Max.	Unit
Supply Voltage	V _{DD}	2.5	3.3	3.7	V
Logic Low Input Voltage	V _{IL}	GND	-	0.3*VDD	V
Logic High Input Voltage	V _{IH}	0.7*VDD	-	VDD	V
Logic Low Output Voltage	V _{OL}	GND	-	0.2*VDD	V
Logic High Output Voltage	V _{OH}	0.8*VDD	-	VDD	V
Power Consumption Normal Mode (All White)	P _C	-	(144)	-	mW

5. Backlight Characteristic

5.1. Backlight Characteristics

Item	Symbol	Condition	Min.	Typ.	Max.	Unit
Forward Voltage	V _F	Ta=25 °C, I _F =15mA/LED	8.4	9.3	9.9	V
Forward Current	I _F	Ta=25 °C, V _F =3.1V/LED	-	15	-	mA
Power Dissipation	P _d		-	139.5	-	mW
Uniformity	Avg		70	-	-	%
LED Lifetime (25°C)	-		20,000	30,000	-	Hrs
Drive Method	Constant Current					
LED Configuration	3 White LEDs in Series					

Note1: LED life time defined as follows: The final brightness is at 50% of original brightness.
The environmental conducted under ambient air flow, at Ta=25±2 °C, 60%RH±5%, I_F=15mA.

5.2. Backlighting Circuit

B/L circuit diagram

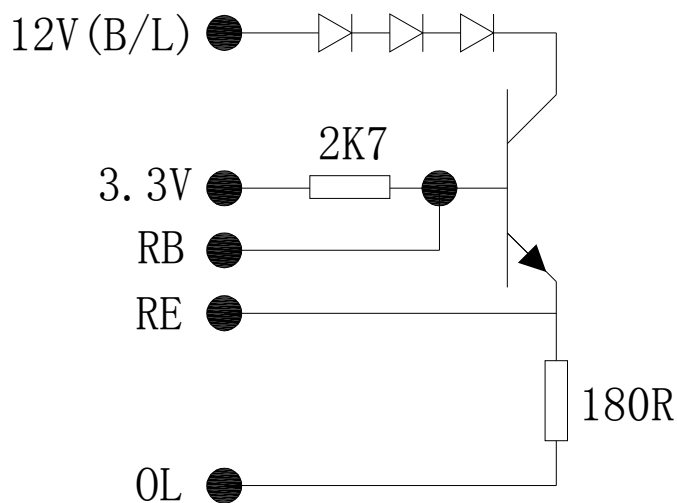

6. Optical Characteristics

6.1. Optical Characteristics

Ta=25°C, VDD=3.3V, TN LC+ Polarizer

	Item	Symbol	Condition	Specification			Unit	
				Min.	Typ.	Max.		
Backlight On (Transmissive Mode)	Luminance on TFT ($I_f = 15\text{mA/LED}$)	Lv	Normally viewing angle $\theta_x = \phi_y = 0^\circ$	350	440	-	cd/m ²	
	Contrast Ratio(See 6.3)	CR		250	500	-		
	Response Time (See 6.2)	TR+TF		-	40	60	ms	
	Chromaticity Transmissive (See 6.5)	Red	XR	Center CR≥10	0.569	0.619	0.669	
			YR		0.314	0.364	0.414	
		Green	XG		0.269	0.319	0.369	
			YG		0.590	0.640	0.690	
		Blue	XB		0.097	0.147	0.197	
			YB		0.057	0.107	0.157	
	White	XW	0.254	0.304	0.354			
YW		0.323	0.373	0.423				
Viewing Angle (See 6.4)	Horizontal	θ_{x+}	Center CR≥10	60	80	-	Deg.	
		θ_{x-}		60	80	-		
	Vertical	ϕ_{y+}		60	80	-		
		ϕ_{y-}		60	80	-		
NTSC Ratio(Gamut)				-	(58)	-	%	

6.2. Definition of Response Time

6.2.1. Normally Black Type (Negative)

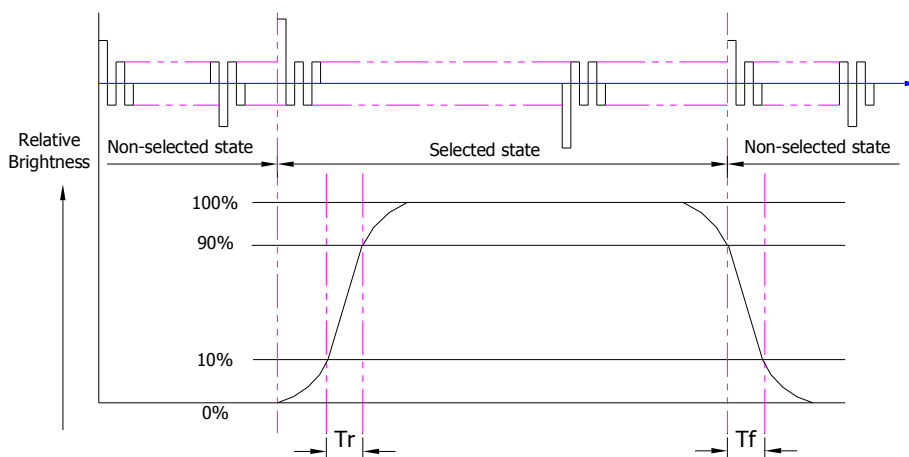

Tr is the time it takes to change from non-selected stage with relative luminance 10% to selected state with relative luminance 90%;

Tf is the time it takes to change from selected state with relative luminance 90% to non-selected state with relative luminance 10%.

Note: Measuring machine: LCD-5100

6.2.2. Normally White Type (Positive)

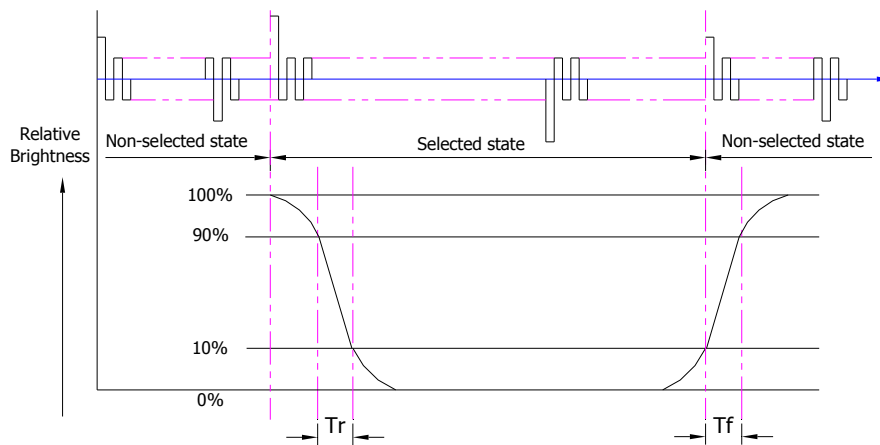

Tr is the time it takes to change from non-selected stage with relative luminance 90% to selected state with relative luminance 10%;

Tf is the time it takes to change from selected state with relative luminance 10% to non-selected state with relative luminance 90%;

Note: Measuring machine: LCD-5100 or EQUI

6.3. Definition of Contrast Ratio

Contrast is measured perpendicular to display surface in reflective and transmissive mode. The measurement condition is:

Measuring Equipment	Eldim or Equivalent
Measuring Point Diameter	3mm//1mm
Measuring Point Location	Active Area centre point
Test pattern	A: All Pixels white
	B: All Pixel black
Contrast setting	Maximum

Definitions: CR (Contrast) = Luminance of White Pixel / Luminance of Black Pixel

6.4. Definition of Viewing Angles

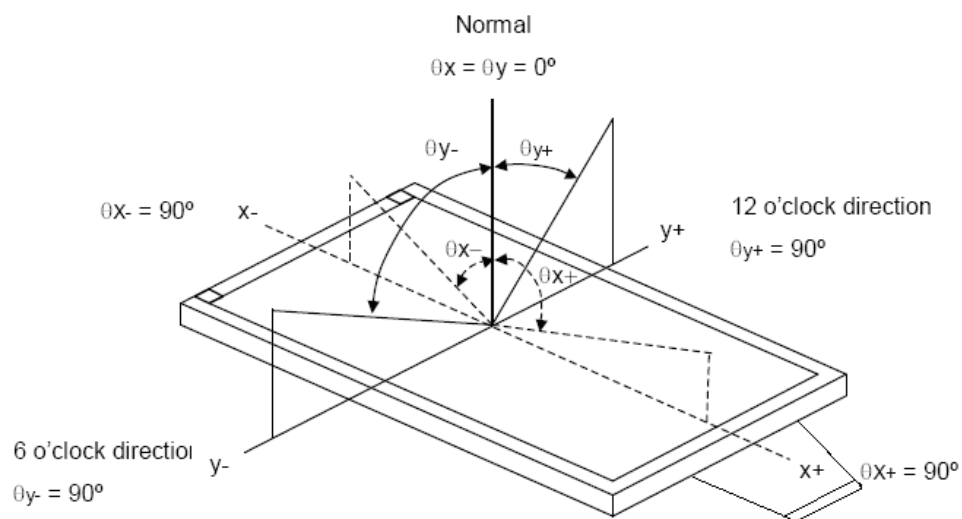

Measuring machine: LCD-5100 or EQUI

6.5. Definition of Color Appearance

R, G, B and W are defined by (x, y) on the IE chromaticity diagram

NTSC=area of RGB triangle/area of NTSC triangleX100%

Measuring picture: Red, Green, Blue and White (Measuring machine: BM-7)

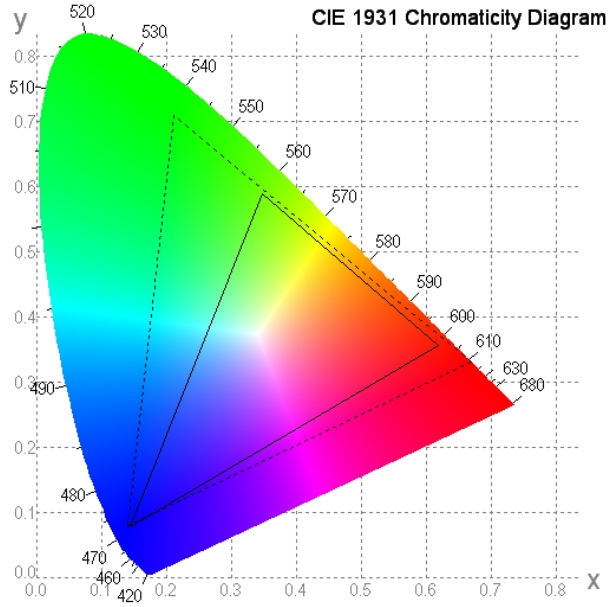

6.6. Definition of Surface Luminance, Uniformity and Transmittance

Using the transmissive mode measurement approach, measure the white screen luminance of the display panel and backlight.

- 6.6.1. Surface Luminance: $L_v = \text{average} (L_{P1}:L_{P9})$
- 6.6.2. Uniformity = $\text{Minimal} (L_{P1}:L_{P9}) / \text{Maximal} (L_{P1}:L_{P9}) * 100\%$
- 6.6.3. Transmittance = $L_v \text{ on LCD} / L_v \text{ on Backlight} * 100\%$

Note: Measuring machine: BM-7

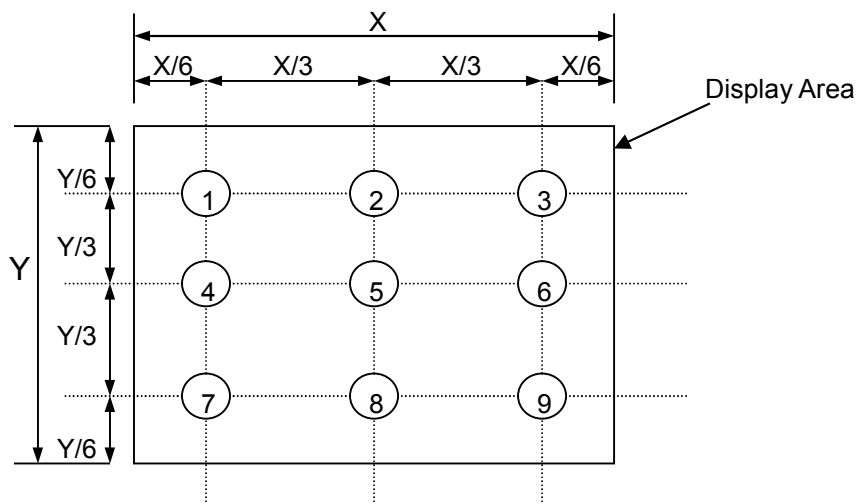

7. Block Diagram and Power Supply

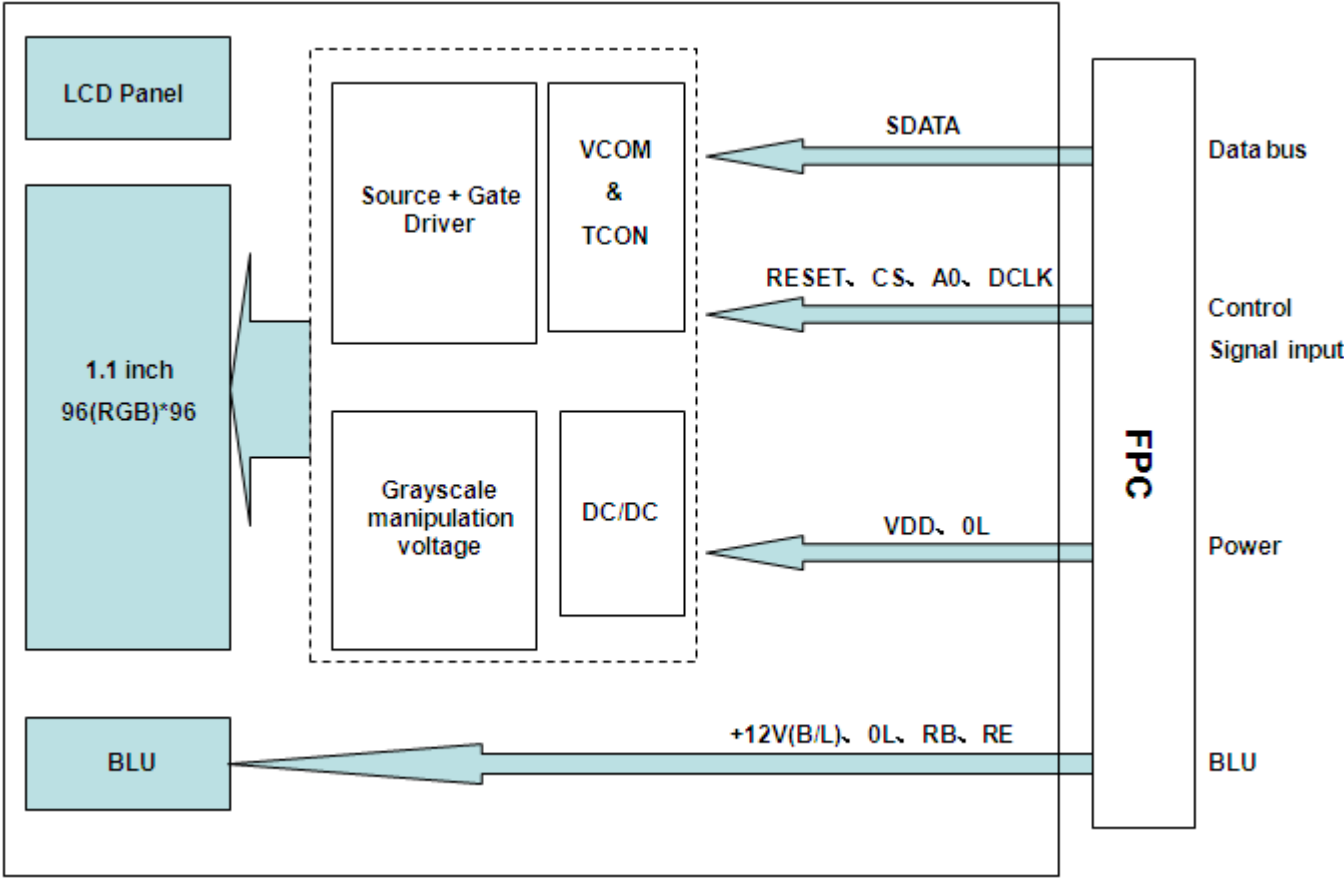

8. Interface Pins Definition

No.	Symbol	Function	Remark
1	0L	Ground.	
2	+12V(B/L)	LED Light Anode.	
3	0L	Ground.	
4	VDD(3.3V)	Power supply.	
5	0L	Ground.	
6	RESET	Reset signal.	
7	NC	No connection.	
8	0L	Ground.	
9	CS	Chip select signal.	
10	A0	The signal for command or parameter select.	
11	DCLK	Serial clock signal.	
12	SDATA	Serial data input pin.	
13	NC	No connection.	
14	0L	Ground.	
15	NC	No connection.	
16	0L	Ground.	
17	RB	Base of Bi-POLAR TRANSISTOR.	
18	RE	Emitter of Bi-POLAR TRANSISTOR.	
19	NC	No connection.	
20	NC	No connection.	
21	NC	No connection.	
22	RE	Emitter of Bi-POLAR TRANSISTOR.	
23	0L	Ground.	
24	+12V(B/L)	LED Light Anode.	
25	0L	Ground.	

9. AC Characteristics

9.1. Serial Interface Characteristics (4-line Serial)

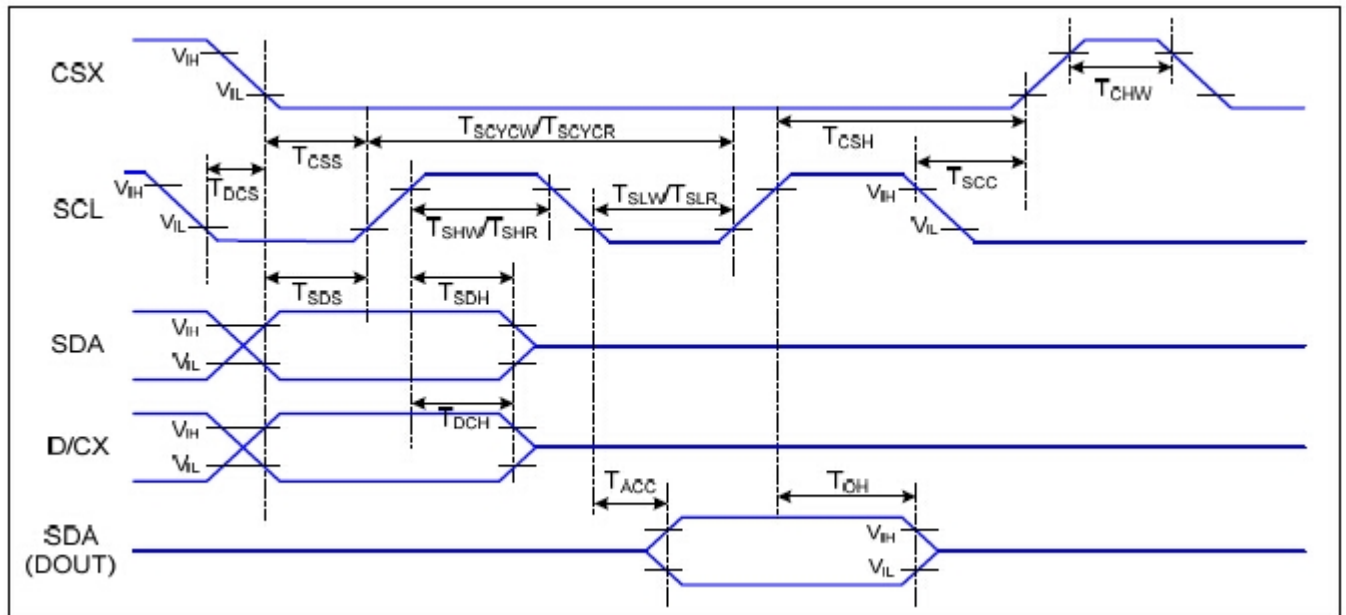

T_a=25 °C, V_{DDI}=1.65~3.7V, V_{DD}=2.5~4.8V

Signal	Symbol	Parameter	MIN	MAX	Unit	Description
CSX	T _{CSS}	Chip Select Setup Time (Write)	45		ns	
	T _{CSH}	Chip Select Hold Time (Write)	45		ns	
	T _{CSS}	Chip Select Setup Time (Read)	60		ns	
	T _{SCC}	Chip Select Hold Time (Read)	65		ns	
	T _{CHW}	Chip Select "H" Pulse Width	40		ns	
SCL	T _{SCYCW}	Serial Clock Cycle (Write)	66		ns	-Write Command & Data Ram
	T _{SHW}	SCL "H" Pulse Width (Write)	15		ns	
	T _{SLW}	SCL "L" Pulse Width (Write)	15		ns	
	T _{SCYCR}	Serial Clock Cycle (Read)	150		ns	-Read Command & Data Ram
	T _{SHR}	SCL "H" Pulse Width (Read)	60		ns	
	T _{SLR}	SCL "L" Pulse Width (Read)	60		ns	
D/CX	T _{DCS}	D/CX Setup Time	10		ns	
	T _{DCX}	D/CX Hold Time	10		ns	
SDA (DIN) (DOUT)	T _{SDS}	Data Setup Time	10		ns	For Maximum CL=30pF For Minimum CL=8pF
	T _{SDH}	Data Hold Time	10		ns	
	T _{ACC}	Access Time	10	50	ns	
	T _{TOH}	Output Disable Time	15	50	ns	

10. Quality Assurance

10.1 Purpose

This standard for Quality Assurance assures the quality of LCD module products supplied to customer.

10.2 Standard for Quality Test

10.2.1 Sampling Plan:

GB2828.1-2012

Single sampling, general inspection level II

10.2.2 Sampling Criteria:

Visual inspection: AQL 1.5%

Electrical functional: AQL 0.65%.

10.2.3 Reliability Test:

Detailed requirement refer to Reliability Test Specification.

10.3 Nonconforming Analysis & Disposition

10.3.1 Nonconforming analysis:

10.3.1.1 Customer should provide overall information of non-conforming sample for their complaints.

10.3.1.2 After receipt of detailed information from customer, the analysis of nonconforming parts usually should be finished in one week.

10.3.1.3 If cannot finish the analysis on time, customer will be notified with the progress status.

10.3.2 Disposition of nonconforming:

10.3.2.1 Non-conforming product over PPM level will be replaced.

10.3.2.2 The cause of non-conformance will be analyzed. Corrective action will be discussed and implemented.

10.4 Agreement Items

Shall negotiate with customer if the following situation occurs:

10.4.1 There is any discrepancy in standard of quality assurance.

10.4.2 Additional requirement to be added in product specification.

10.4.3 Any other special problem.

10.5 Standard of the Product Visual Inspection

10.5.1 Appearance inspection:

10.5.1.1 The inspection must be under illumination about 1000 – 1500 lx, and the distance of view must be at 30cm ± 2cm.

10.5.1.2 The viewing angle should be 45° from the vertical line without reflection light or follows customer's viewing angle specifications.

10.5.1.3 Definition of area: A Zone: Active Area, B Zone: Viewing Area,

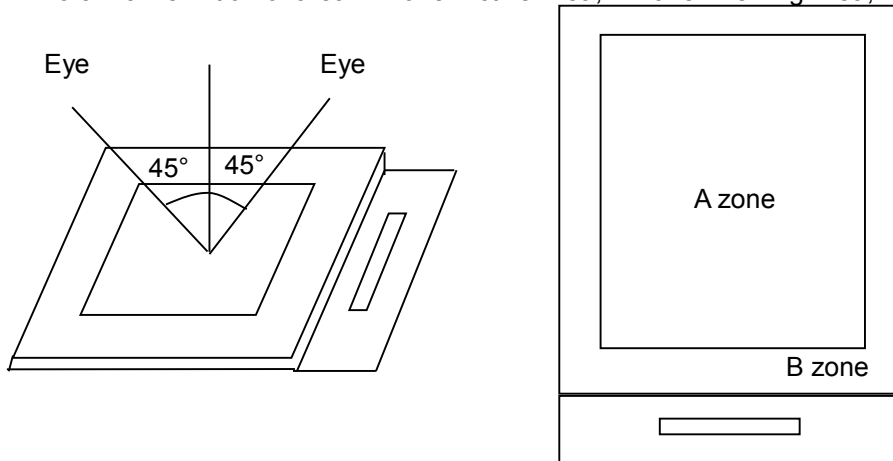

10.5.2 Basic principle:

10.5.2.1 A set of sample to indicate the limit of acceptable quality level must be discussed by both us and customer when there is any dispute happened.

10.5.2.2 New item must be added on time when it is necessary.

10.6 Inspection Specification

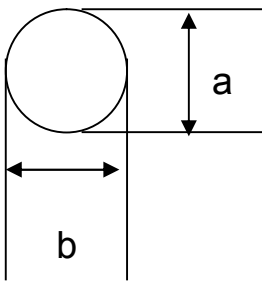
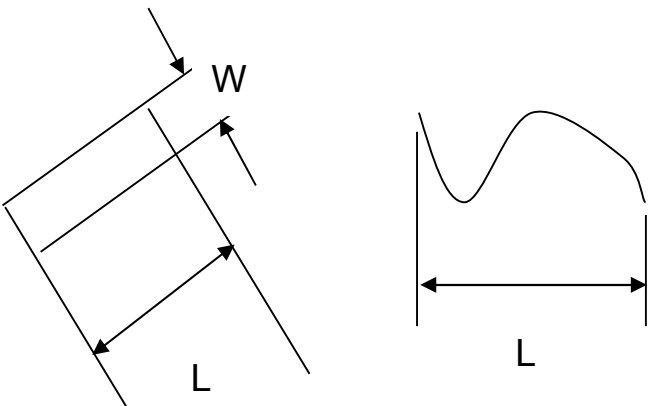
No.	Item	Criteria (Unit: mm)																		
01	Black / White spot Foreign material (Round type) Pinholes Stain Particles inside cell. (Minor defect)	 <table border="1" data-bbox="909 347 1412 689"> <thead> <tr> <th>Size</th> <th>Area</th> <th>Acc. Qty</th> </tr> </thead> <tbody> <tr> <td>$\phi \leq 0.10$</td> <td></td> <td>Ignore</td> </tr> <tr> <td>$0.10 < \phi \leq 0.15$</td> <td></td> <td>2</td> </tr> <tr> <td>$0.15 < \phi \leq 0.25$</td> <td></td> <td>1</td> </tr> <tr> <td>$0.25 < \phi$</td> <td></td> <td>0</td> </tr> <tr> <td>Total</td> <td></td> <td>2 no include $\phi \leq 0.10$</td> </tr> </tbody> </table> <p>$\phi = (a + b) / 2$ Distance between 2 defects should more than 3mm apart.</p>	Size	Area	Acc. Qty	$\phi \leq 0.10$		Ignore	$0.10 < \phi \leq 0.15$		2	$0.15 < \phi \leq 0.25$		1	$0.25 < \phi$		0	Total		2 no include $\phi \leq 0.10$
Size	Area	Acc. Qty																		
$\phi \leq 0.10$		Ignore																		
$0.10 < \phi \leq 0.15$		2																		
$0.15 < \phi \leq 0.25$		1																		
$0.25 < \phi$		0																		
Total		2 no include $\phi \leq 0.10$																		
02	Electrical Defect (Minor defect)	<table border="1" data-bbox="555 795 1404 1008"> <thead> <tr> <th></th> <th>Display Area</th> <th>Total</th> <th rowspan="3">Note1</th> </tr> </thead> <tbody> <tr> <td>Bright dot</td> <td>0</td> <td>0</td> </tr> <tr> <td>Dark dot</td> <td>$N \leq 2$</td> <td>$N \leq 2$</td> </tr> <tr> <td>Total dot</td> <td>$N \leq 2$</td> <td>$N \leq 2$</td> <td></td> </tr> <tr> <td>Mura</td> <td colspan="2">Not visible through 5% ND filters.</td> <td>Note 2</td> </tr> </tbody> </table> <p>Remark: 1. Bright dot caused by scratch and foreign object accords to item 1.</p>		Display Area	Total	Note1	Bright dot	0	0	Dark dot	$N \leq 2$	$N \leq 2$	Total dot	$N \leq 2$	$N \leq 2$		Mura	Not visible through 5% ND filters.		Note 2
	Display Area	Total	Note1																	
Bright dot	0	0																		
Dark dot	$N \leq 2$	$N \leq 2$																		
Total dot	$N \leq 2$	$N \leq 2$																		
Mura	Not visible through 5% ND filters.		Note 2																	
03	Black and White line Scratch Foreign material (Line type) (Minor defect)	 <table border="1" data-bbox="614 1657 1289 1960"> <thead> <tr> <th>Length</th> <th>Width</th> <th>Acc. Qty</th> </tr> </thead> <tbody> <tr> <td>/</td> <td>$W \leq 0.02$</td> <td>Ignore</td> </tr> <tr> <td>$L \leq 5.0$</td> <td>$0.02 < W \leq 0.05$</td> <td rowspan="2">6</td> </tr> <tr> <td>$L \leq 2.0$</td> <td>$0.05 < W \leq 0.10$</td> </tr> <tr> <td>/</td> <td>$0.1 < W$</td> <td>According to Item 1</td> </tr> </tbody> </table> <p>A) Clear B) Unclear</p>	Length	Width	Acc. Qty	/	$W \leq 0.02$	Ignore	$L \leq 5.0$	$0.02 < W \leq 0.05$	6	$L \leq 2.0$	$0.05 < W \leq 0.10$	/	$0.1 < W$	According to Item 1				
Length	Width	Acc. Qty																		
/	$W \leq 0.02$	Ignore																		
$L \leq 5.0$	$0.02 < W \leq 0.05$	6																		
$L \leq 2.0$	$0.05 < W \leq 0.10$																			
/	$0.1 < W$	According to Item 1																		

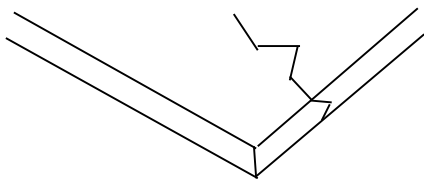
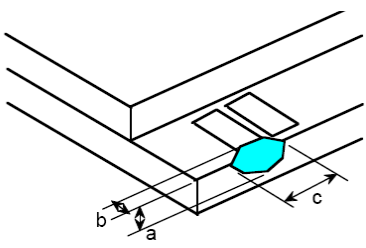
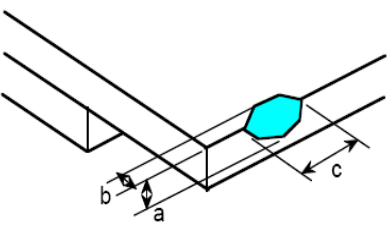
		<table border="1"> <thead> <tr> <th>Length</th> <th>Width</th> <th>Acc. Qty</th> </tr> </thead> <tbody> <tr> <td>/</td> <td>$W \leq 0.05$</td> <td>Ignore</td> </tr> <tr> <td>$L \leq 10$</td> <td>$0.05 < W \leq 0.3$</td> <td rowspan="2">6</td> </tr> <tr> <td>$L \leq 2.0$</td> <td>$0.3 < W \leq 0.5$</td> </tr> <tr> <td>/</td> <td>$0.5 < W$</td> <td>According to Item 1</td> </tr> </tbody> </table> <p>“Clear”: the shade and size of the line or dot are not changed with the LCD operation voltage changing. the defect looks very apparent. “Unclear”: the shade and size of the line or dot are not changed with the LCD operation voltage changing. the defect looks not so apparent.</p>	Length	Width	Acc. Qty	/	$W \leq 0.05$	Ignore	$L \leq 10$	$0.05 < W \leq 0.3$	6	$L \leq 2.0$	$0.3 < W \leq 0.5$	/	$0.5 < W$	According to Item 1
Length	Width	Acc. Qty														
/	$W \leq 0.05$	Ignore														
$L \leq 10$	$0.05 < W \leq 0.3$	6														
$L \leq 2.0$	$0.3 < W \leq 0.5$															
/	$0.5 < W$	According to Item 1														
04	Glass Crack (Minor defect)	 <p>Crack is potential to enlarge, any type is not allowed.</p>														
05	Glass Chipping Pad Area: (Minor defect)	 <table border="1"> <thead> <tr> <th>Length and Width</th> <th>Acc. Qty</th> </tr> </thead> <tbody> <tr> <td>$c > 3.0, b < 1.0$</td> <td>1</td> </tr> <tr> <td>$c < 3.0, b < 1.0$</td> <td>3</td> </tr> <tr> <td colspan="2">$a < \text{Glass Thickness}$</td> </tr> </tbody> </table>	Length and Width	Acc. Qty	$c > 3.0, b < 1.0$	1	$c < 3.0, b < 1.0$	3	$a < \text{Glass Thickness}$							
Length and Width	Acc. Qty															
$c > 3.0, b < 1.0$	1															
$c < 3.0, b < 1.0$	3															
$a < \text{Glass Thickness}$																
06	Glass Chipping Rear of Pad Area: (Minor defect)	 <table border="1"> <thead> <tr> <th>Length and Width</th> <th>Acc. Qty</th> </tr> </thead> <tbody> <tr> <td>$c > 3.0, b < 1.0$</td> <td>1</td> </tr> <tr> <td>$c < 3.0, b < 1.0$</td> <td>2</td> </tr> <tr> <td>$c < 3.0, b < 0.5$</td> <td>4</td> </tr> <tr> <td colspan="2">$a < \text{Glass Thickness}$</td> </tr> </tbody> </table>	Length and Width	Acc. Qty	$c > 3.0, b < 1.0$	1	$c < 3.0, b < 1.0$	2	$c < 3.0, b < 0.5$	4	$a < \text{Glass Thickness}$					
Length and Width	Acc. Qty															
$c > 3.0, b < 1.0$	1															
$c < 3.0, b < 1.0$	2															
$c < 3.0, b < 0.5$	4															
$a < \text{Glass Thickness}$																

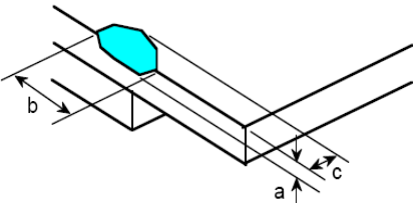
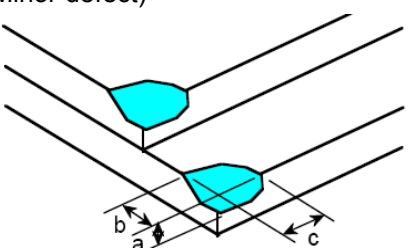
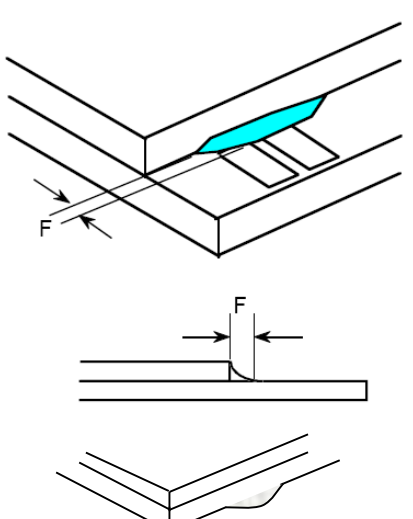
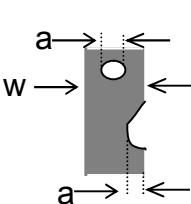
<p>7</p>	<p>Glass Chipping Except Pad Area: (Minor defect)</p> 	<table border="1"> <thead> <tr> <th>Length and Width</th> <th>Acc. Qty</th> </tr> </thead> <tbody> <tr> <td>$c > 3.0, b < 1.0$</td> <td>1</td> </tr> <tr> <td>$c < 3.0, b < 1.0$</td> <td>2</td> </tr> <tr> <td>$c < 3.0, b < 0.5$</td> <td>4</td> </tr> <tr> <td colspan="2" style="text-align: center;">$a < \text{Glass Thickness}$</td> </tr> </tbody> </table>	Length and Width	Acc. Qty	$c > 3.0, b < 1.0$	1	$c < 3.0, b < 1.0$	2	$c < 3.0, b < 0.5$	4	$a < \text{Glass Thickness}$	
Length and Width	Acc. Qty											
$c > 3.0, b < 1.0$	1											
$c < 3.0, b < 1.0$	2											
$c < 3.0, b < 0.5$	4											
$a < \text{Glass Thickness}$												
<p>08</p>	<p>Glass Corner Chipping: (Minor defect)</p> 	<table border="1"> <thead> <tr> <th>Length and Width</th> <th>Acc. Qty</th> </tr> </thead> <tbody> <tr> <td>$c < 3.0, b < 3.0$</td> <td>Ignore</td> </tr> <tr> <td colspan="2" style="text-align: center;">$a < \text{Glass Thickness}$</td> </tr> </tbody> </table>	Length and Width	Acc. Qty	$c < 3.0, b < 3.0$	Ignore	$a < \text{Glass Thickness}$					
Length and Width	Acc. Qty											
$c < 3.0, b < 3.0$	Ignore											
$a < \text{Glass Thickness}$												
<p>09</p>	<p>Glass Burr: (Minor defect)</p> 	<table border="1"> <thead> <tr> <th>Length</th> <th>Acc. Qty</th> </tr> </thead> <tbody> <tr> <td>$F < 1.0$</td> <td>Ignore</td> </tr> </tbody> </table> <p>Glass burr don't affect assemble and module dimension.</p>	Length	Acc. Qty	$F < 1.0$	Ignore						
Length	Acc. Qty											
$F < 1.0$	Ignore											
<p>10</p>	<p>FPC Defect: (Minor defect)</p> 	<p>10.1 Dent, pinhole width $a < w/3$. (w: circuitry width.)</p> <p>10.2 Open circuit is unacceptable.</p> <p>10.3 No oxidation, contamination and distortion.</p>										

11	Bubble on Polarizer (Minor defect)	<table border="1"> <thead> <tr> <th>Diameter</th> <th>Acc. Qty</th> </tr> </thead> <tbody> <tr> <td>$\varphi \leq 0.30$</td> <td>Ignore</td> </tr> <tr> <td>$0.30 < \varphi \leq 1.0$</td> <td>3</td> </tr> <tr> <td>$1.0 < \varphi \leq 1.5$</td> <td>1</td> </tr> <tr> <td>$1.5 < \varphi$</td> <td>None</td> </tr> </tbody> </table>	Diameter	Acc. Qty	$\varphi \leq 0.30$	Ignore	$0.30 < \varphi \leq 1.0$	3	$1.0 < \varphi \leq 1.5$	1	$1.5 < \varphi$	None
		Diameter	Acc. Qty									
		$\varphi \leq 0.30$	Ignore									
		$0.30 < \varphi \leq 1.0$	3									
		$1.0 < \varphi \leq 1.5$	1									
$1.5 < \varphi$	None											
12	Dent on Polarizer (Minor defect)	<table border="1"> <thead> <tr> <th>Diameter</th> <th>Acc. Qty</th> </tr> </thead> <tbody> <tr> <td>$\varphi \leq 0.30$</td> <td>Ignore</td> </tr> <tr> <td>$0.30 < \varphi \leq 1.0$</td> <td>3</td> </tr> <tr> <td>$1.0 < \varphi \leq 1.5$</td> <td>1</td> </tr> <tr> <td>$1.5 < \varphi$</td> <td>None</td> </tr> </tbody> </table>	Diameter	Acc. Qty	$\varphi \leq 0.30$	Ignore	$0.30 < \varphi \leq 1.0$	3	$1.0 < \varphi \leq 1.5$	1	$1.5 < \varphi$	None
		Diameter	Acc. Qty									
		$\varphi \leq 0.30$	Ignore									
		$0.30 < \varphi \leq 1.0$	3									
		$1.0 < \varphi \leq 1.5$	1									
$1.5 < \varphi$	None											
13	Bezel	13.1 No rust, distortion on the Bezel. 13.2 No visible fingerprints, stains or other contamination.										
14	Touch Panel	D: Diameter W: width L: length 14.1 Spot: $D < 0.25$ is acceptable $0.25 \leq D \leq 0.4$ 2dots are acceptable and the distance between defects should more than 10 mm. $D > 0.4$ is unacceptable 14.2 Dent: $D > 0.40$ is unacceptable 14.3 Scratch: $W \leq 0.03$, $L \leq 10$ is acceptable, $0.03 < W \leq 0.10$, $L \leq 10$ is acceptable Distance between 2 defects should more than 10 mm. $W > 0.10$ is unacceptable.										
15	PCB	15.1 No distortion or contamination on PCB terminals. 15.2 All components on PCB must same as documented on the BOM/component layout. 15.3 Follow IPC-A-600F.										
16	Soldering	Follow IPC-A-610C standard										
17	Electrical Defect (Major defect)	The below defects must be rejected. 17.1 Missing vertical / horizontal segment, 17.2 Abnormal Display. 17.3 No function or no display. 17.4 Current exceeds product specifications. 17.5 LCD viewing angle defect. 17.6 No Backlight. 17.7 Dark Backlight. 17.8 Touch Panel no function.										

Remark: LCD Panel Broken shall be rejected. Defect out of LCD viewing area is acceptable.

10.7 Classification of Defects

10.7.1 Visual defects (Except no / wrong label) are treated as minor defect and electrical defect is major.

10.7.2 Two minor defects are equal to one major in lot sampling inspection.

10.8 Identification/marketing criteria

Any unit with illegible / wrong /double or no marking/ label shall be rejected.

10.9 Packaging

10.9.1 There should be no damage of the outside carton box, each packaging box should have one identical label.

10.9.2 Modules inside package box should have compliant mark.

10.9.3 All direct package materials shall offer ESD protection

Note1: Bright dot is defined as the defective area of the dot is larger than 50% of one sub-pixel area.

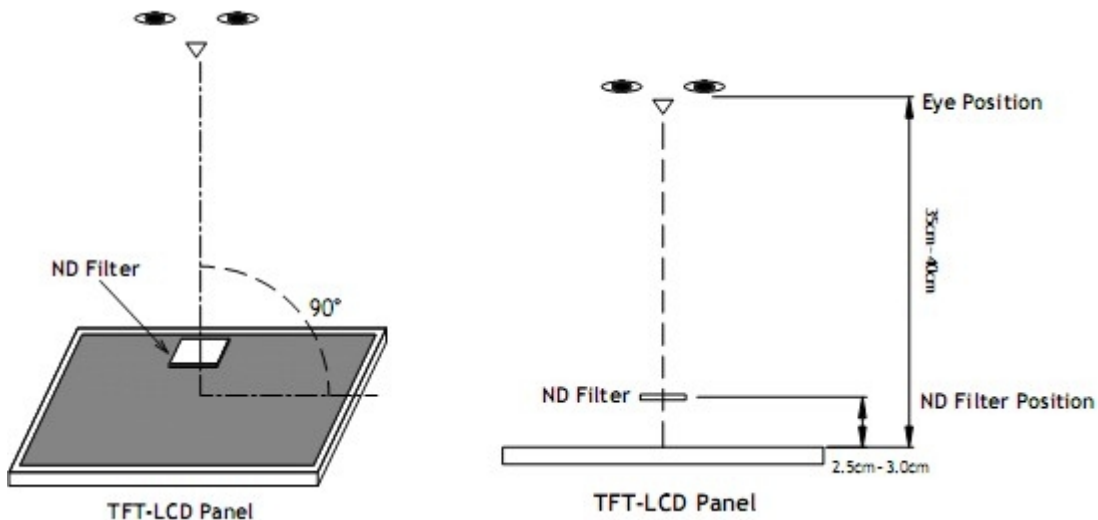

Bright dot: The bright dot size defect at black display pattern. It can be recognized by 2% transparency of filter when the distance between eyes and panel is $350\text{mm} \pm 50\text{mm}$.

Dark dot: Cyan, Magenta or Yellow dot size defect at white display pattern. It can be recognized by 5% transparency of filter when the distance between eyes and panel is $350\text{mm} \pm 50\text{mm}$.

Note2: Mura on display which appears darker / brighter against background brightness on parts of display area.

11. Reliability Specification

No	Item	Condition	Quantity	Criteria
1	High Temperature Operating	70°C, 96Hrs	2	GB/T2423.2-2008
2	Low Temperature Operating	-20°C, 96Hrs	2	GB/T2423.1-2008
3	High Humidity	50°C, 90%RH, 96Hrs	2	GB/T2423.3-2006
4	High Temperature Storage	80°C, 96Hrs	2	GB/T2423.2-2008
5	Low Temperature Storage	-30°C, 96Hrs	2	GB/T2423.1-2008
6	Thermal Cycling Test	-20°C, 60min~70°C, 60min, 20 cycles.	2	GB/T2423.22-2012
7	Packing vibration	Frequency range:10Hz~50Hz Acceleration of gravity:5G X, Y, Z 30 min for each direction.	2	GB/T5170.14-2009
8	Electrical Static Discharge	Air: ±4KV 150pF/330Ω 5 times	2	GB/T17626.2-2006
		Contact: ±2KV 150pF/330Ω 5 times		
9	Drop Test (Packaged)	Height:80 cm,1 corner, 3 edges, 6 surfaces.	2	GB/T2423.8-1995

Note1. No deflection cosmetic and operational function allowable.

Note2. Total current Consumption should be below double of initial value

Note3. In case of malfunction defect caused by ESD damage, if it would be recovered to normal state after resetting, it would be judged as a good part.

12. Precautions and Warranty

12.1 Safety

12.1.1 The liquid crystal in the LCD is poisonous. Do not put it in your mouth. If the liquid crystal touches your skin or clothes, wash it off immediately using soap and water.

12.1.2 Since the liquid crystal cells are made of glass, do not apply strong impact on them. Handle with care.

12.2 Handling

12.2.1 Reverse and use within ratings in order to keep performance and prevent damage.

12.2.2 Do not wipe the polarizer with dry cloth, as it might cause scratch. If the surface of the LCD needs to be cleaned, wipe it swiftly with cotton or other soft cloth soaked with petroleum IPA, do not use other chemicals.

12.3 Storage

12.3.1 Do not store the LCD module beyond the specified temperature ranges.

12.4 Metal Pin (Apply to Products with Metal Pins)

12.4.1 Pins of LCD and Backlight

12.4.1.1 Solder tip can touch and press on the tip of Pin LEAD during the soldering

12.4.1.2 Recommended Soldering Conditions

Solder Type: Sn96.3~94-Ag3.3~4.3-Cu0.4~1.1

Maximum Solder Temperature: 370℃

Maximum Solder Time: 3s at the maximum temperature

Recommended Soldering Temp: 350±20℃

Typical Soldering Time: ≤3s

12.4.1.3 Solder Wetting

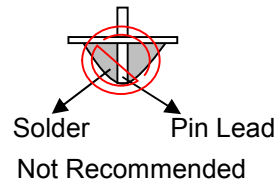
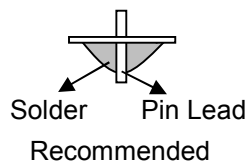

12.4.2 Pins of EL

12.4.2.1 Solder tip can touch and press on the tip of EL leads during soldering.

12.4.2.2 No Solder Paste on the soldering pad on the motherboard is recommended.

12.4.2.3 Recommended Soldering Conditions

Solder type: Nippon Alimit Leadfree SR-34, size 0.5mm

Recommended Solder Temperature: 270~290℃

Typical Soldering Time: ≤2s

Minimum solder distance from EL lamp (body):2.0mm

12.4.2.4 No horizontal press on the EL leads during soldering.

12.4.2.5 180° bend EL leads three times is not allowed.

12.4.2.6 Solder Wetting

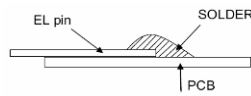

Recommended

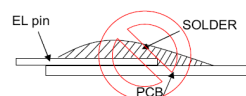

Not Recommended

12.4.2.7 The type of the solder iron:

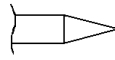

Recommended

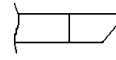

Not Recommended

12.4.2.8 Solder Pad

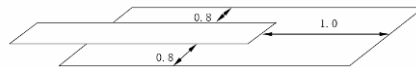

12.5 Operation

- 12.5.1 Do not drive LCD with DC voltage
- 12.5.2 Response time will increase below lower temperature
- 12.5.3 Display may change color with different temperature
- 12.5.4 Mechanical disturbance during operation, such as pressing on the display area, may cause the segments to appear “fractured”.

12.6 Static Electricity

- 12.6.1 CMOS LSIs are equipped in this unit, so care must be taken to avoid the electro-static charge, by ground human body, etc.
- 12.6.2 The normal static prevention measures should be observed for work clothes and benches.
- 12.6.3 The module should be kept into anti-static bags or other containers resistant to static for storage.

12.7 Limited Warranty

- 12.7.1 Our warranty liability is limited to repair and/or replacement. We will not be responsible for any consequential loss.
- 12.7.2 If possible, we suggest customer to use up all modules in six months. If the module storage time over twelve months, we suggest that recheck it before the module be used.
- 12.7.3 After the product shipped, any product quality issues must be feedback within eighteen months, otherwise, we will not be responsible for the subsequent or consequential events.

13. Outline Drawing

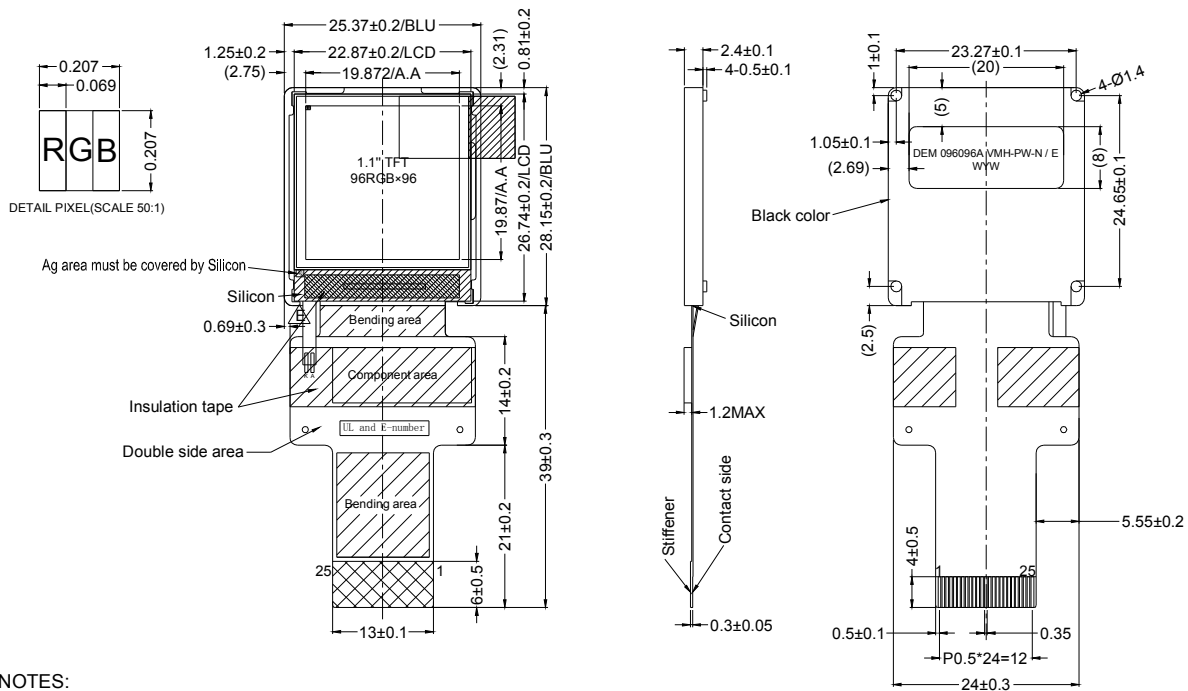

NOTES:

1. Display Size: 1.1" TFT
2. Viewing Direction: 80°/80°/80°/80°(typ)
3. Display Mode: IPS, Transmissive / Normal Black / Glare
4. Operation Temperature: -20°C to +70°C
5. Storage Temperature: -30°C to +80°C
6. Driver IC: ST7735S (Sitronix)
7. Power Supply Voltage: 3.3 Volt (typ.)
8. Backlight: White (3 LEDs) / 9.3Volt / 15mA / 440cd/m2 (typ.)
LED Lifetime: 30.000h (typ.)

* Unspecification Tolerance are ± 0.2mm

B/L Circuit Diagram

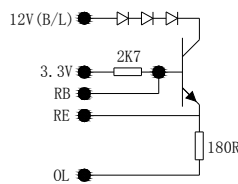

Pin assignment	
PIN	SYMBOL
1	OL
2	+12V (B/L)
3	OL
4	VDD (3.3V)
5	OL
6	RESET
7	NC
8	OL
9	CS
10	A0
11	DCLK
12	SDATA
13	NC
14	OL
15	NC
16	OL
17	RB
18	RE
19	NC
20	NC
21	NC
22	RE
23	OL
24	12V (B/L)
25	OL

X-ON Electronics

Largest Supplier of Electrical and Electronic Components

Click to view similar products for [TFT Displays & Accessories](#) category:

Click to view products by [Display Elektronik](#) manufacturer:

Other Similar products are found below :

[OAI-80038AA-2013-A](#) [HDA430T-3G1H](#) [T-51750GD065J-LW-BGN](#) [NB-ATT01](#) [NL8060BC26-35C](#) [TCG104SVLQAPNN-AN20](#) [OAI-80038AA-2008-A](#) [315-U004B15300](#) [EIC-LCD-1080P](#) [NL10276BC20-18C](#) [NLB121XG01L-01](#) [DEM 128160D](#) [TMH-PW-N](#) [RFE43BU-AIW-DNG](#) [RFC350X-AWW-DNG](#) [RFS390E-AWW-DNN](#) [DEM 480272G2](#) [VMX-PW-N \(A-TOUCH\)](#) [PH800480T013-ICA](#) [DEM 1024600N](#) [VMX-PW-N \(C-TOUCH\)](#) [DEM 1024600P](#) [VMH-PW-N \(C-TOUCH\)](#) [SM-RVT50HQHNWCA0](#) [DEM 240280A](#) [VMH-PW-N](#) [DEM 170320A](#) [VMH-PW-N](#) [PH240320T068-LAB08](#) [DEM 800480T1](#) [TMH-PW-N](#) [PH128128T041-LAA07](#) [DEM 800480Q4](#) [VMX-PW-N \(A-TOUCH\)](#) [PH480272T005-IAC02](#) [DEM 1024600P](#) [VMH-PW-N \(A-TOUCH\)](#) [DEM 800480T1](#) [TMH-PW-N \(C-TOUCH\)](#) [DEM 800480Q4](#) [VMX-PW-N](#) [DEM 800480T1](#) [TMH-PW-N \(A-TOUCH\)](#) [PH320240T-023-I02Q](#) [PH128800T004-ZZA01](#) [RFE430W-1YW-DBS](#) [DEM 1024600N](#) [VMX-PW-N \(A-TOUCH\)](#) [PH240320T074-ZAA01](#) [DEM 480480D](#) [VMX-PW-N \(C-TOUCH\)](#) [SM-RVT50HQSNWN00](#) [SM-RVT50HQHNWC00](#) [PH800480T033-ICB01](#) [RFE430W-AWW-DNN](#) [DEM 096096A](#) [VMH-PW-N](#) [RL0F00050000FGAAASA01](#) [PH320480T009-LAA01](#) [SM-RVT50HQSNWCA0](#) [SM-RVT50HQSNWC00-B](#) [PH320240T028-ZEA01](#) [RFE430W-1YW-DBN](#) [SM-RVT50HQLFWN00](#) [SM-RVT50HQHNWC00-B](#)