

DISPLAY Elektronik GmbH

DATA SHEET

LCD MODULE

DEM 320120A VMH-PW-N

2,9" TFT

Product Specification

Version: 0

25.02.2021

Table of Contents

1. Record of Revision.....	3
2. General Specifications.....	4
3. Input/Output Terminals	5
4. Absolute Maximum Ratings.....	6
5. Electrical Characteristics.....	7
5.2 Driving Backlight.....	7
5.3 Block Diagram	8
6. Interface Timing	9
7. Optical Characteristics	16
8. Environmental / Reliability Tests	20
9. Mechanical Drawing	22
10. Precautions For Use of LCD modules.....	23
10.1 Handling Precautions	23
10.2 Storage Precautions	23
10.3 Inspection Sampling	24
10.4 Inspection Conditions.....	24
10.5. Inspection Criteria	25
10.6 Mechanics specification	28
11. Precautions for Use of LCD modules.....	28

1. Record of Revision

Rev	Issued Date	Description	Editor
0	25.02.2021	First Release.	MH

2. General Specifications

	Feature	Spec
Characteristics	Size	2.9 Inch
	Resolution	320 x RGB x 120
	Interface	18-Bit-RGB
	Connect Type	Connector
	Color Depth	262k
	Technology Type	a-Si
	Display Spec. Pixel Pitch (mm)	0.219 x 0.219
	Pixel Configuration	R.G.B. Vertical Stripe
	Display Mode	Normally Black
	Driver IC	ST7272A
	Viewing Direction	IPS
Mechanical	LCM (W x H x D) (mm)	76.90 x 38.22 x 3.26
	Active Area(mm)	70.08 x 26.28
	With /Without TSP	Without TSP
	Weight (g)	t.b.d.
	LED Numbers	6 LEDs

Note 1: RoHS

Note 2: LCM weight tolerance: +/- 5%

3. Input/Output Terminals

No.	Symbol	Description
1,2	VBL-	Backlight LED Cathode
3,4	VBL+	Backlight LED Anode.
5	Y1(YU)(NC)	No connection
6	X1(XR)(NC)	No connection
7	NC	NC
8	RESET	Reset Signal pin
9	CS(NC)	No connection
10	SCL(NC)	No connection
11	SDA(NC)	No connection
12	SDO(NC)	No connection
13	NC	NC
14~19	B0~B5	Data bus
20,21	NC	NC
22~27	G0~G5	Data bus
28,29	NC	NC
30~35	R0~R5	Data bus
36	HSYNC	Line Synchronous Signal
37	VSYNC	Frame Synchronous Signal
38	DOTCLK	Dot-clock signal and oscillator source
39	GND	Ground
40	IOVCC	Voltage input pin for logic
41	VDD	Booster input voltage pin
42	VDD	Booster input voltage pin
43	Y2(YD)(NC)	No connection
44	X2(XL)(NC)	No connection
45-51	NC	NC
52	DEN	Display enable pin for controller
53	GND	Ground
54	GND	Ground

4. Absolute Maximum Ratings

Item	Symbol	Rating	Unit
Power Supply Voltage	VDD	- 0.3 ~ +4.0	V
IO Supply Voltage	VDDI	- 0.3 ~ +4.0	V
Charge Pump Supply Voltage	PVDD	- 0.3 ~ +4.0	V
Logic Input Voltage Range	VIN	-0.3 ~ VDDI + 0.3	V
Logic Output Voltage Range	VOOUT	-0.3 ~ VDDI + 0.3	V
Operating Temperature Range	TOPR	-30 ~ +85	°C
Storage Temperature Range	TSTG	-40 ~ +125	°C

Note:

1. That the stress exceeds the Limiting Value listed above it may cause the driver IC permanent damage. These values are for stress only. IC should be operated under the DC/AC Characteristic conditions for normal operation. If these conditions are not met, IC operation may be error and the reliability may be deteriorated.
2. Parameters are valid over operating temperature range unless otherwise specified. All voltages are with respect to VSS unless otherwise noted.
3. Insure the voltage levels of VDDI, VDD, PVDD always matches the correct relation:

$$3.0V \leq VDDI \leq VDD = PVDD \leq 3.6V$$
4. VIN should be less than or equal to 3.6V. (VIN ≤ 3.6V)

5. Electrical Characteristics

5.1 Driving TFT LCD Panel

Item	Symbol	MIN	TYP	MAX	Unit	Remark
Supply Voltage	V _{cc}	3.0	3.3	3.6	V	
Input Signal Voltage	Low Level	V _{IL}	GND	-	0.1x VDD	V
	High Level	V _{IH}	0.8x VDD	-	VDD	V
Output Signal Voltage	Low Level	V _{OL}	0	-	0.2*VDD	V
	High Level	V _{OH}	0.8*VDD	-	VDD	V

5.2 Driving Backlight

Item	Symbol	MIN	TYP	MAX	Unit	Remark
Forward Current	I _F	-	20	-	mA	Constant Current
Forward Voltage	V _F	17.6	19.2	20.8	V	
Backlight Power consumption	W _{BL}	-	0.384	-	W	
LED Lifetime	W _{BL}	-	30000	-	h	

Note 1: Each LED: I_F =20 mA, V_F =2.8~3.4V.

Note 2: Optical performance should be evaluated at Ta=25°C only.

Note 3: If LED is driven by high current, high ambient temperature & humidity condition.

The lifetime of LED will be reduced. Operating life means brightness goes down to 50% initial brightness. Typical operating life time is estimated data.



Figure: LED connection of backlight

5.3 Block Diagram

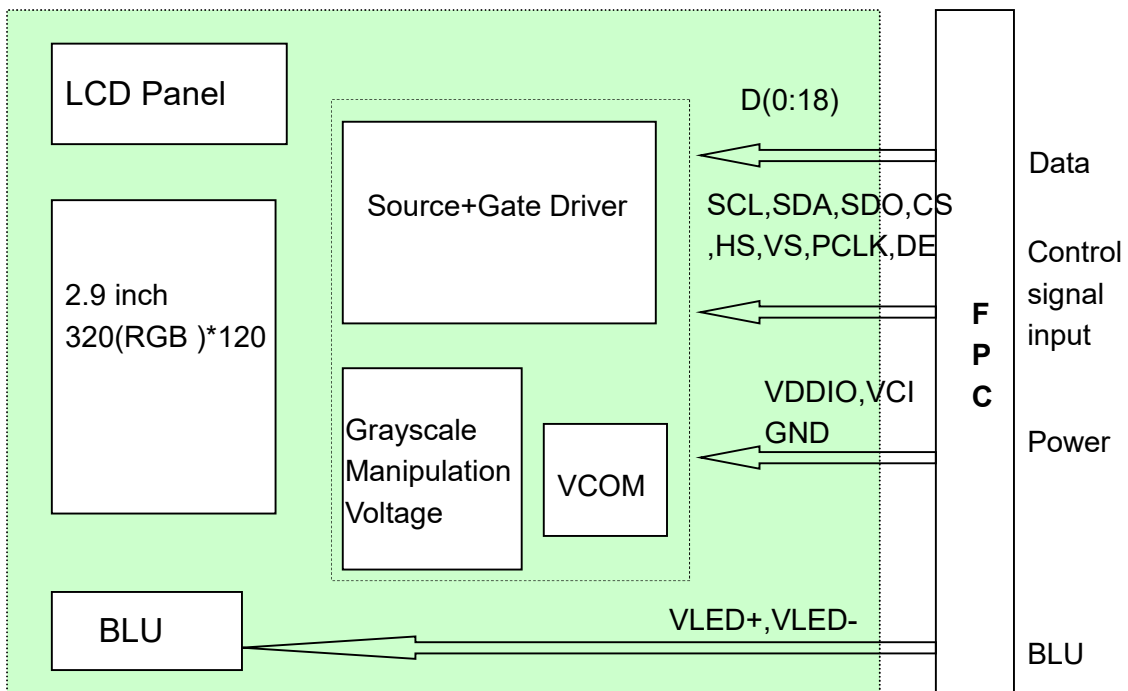

6. Interface Timing

6.1 AC Characteristics

Test Condition: (VDD=VDDP=3.3V, VDDA=5.0V, GND=GNDA=GNDP=0V, TA= 25°C)

Parameter	Symbol	Min.	Typ.	Max.	Unit	Conditions
System Operation Timing						
VDD power source slew time	T _{POr}			1000	us	From 0V to 90% VDD
RSTB active pulse width	T _{RSTB}	40			us	VDD = 3.3V
Input Output Timing						
CLKIN clock time	T _{clk}	33.3/125	-	-	ns	Please refer to timing table(p.32)
HSD to CLKIN	T _{hc}	-	-	1	CLKIN	
HSD width	T _{wh}	1	-	-	CLKIN	
VSD width	T _{vwh}	1	-	-	Th	
HSD period time	T _h	60	63.56	67	us	
VSD setup time	T _{vst}	8	-	-	ns	
VSD hold time	T _{vhd}	10	-	-	ns	
HSD setup time	T _{hst}	8	-	-	ns	
HSD hold time	T _{hhd}	10	-	-	ns	
Data set-up time	T _{dsu}	8	-	-	ns	DIN[23:0] to CLKIN
Data hold time	T _{dhd}	10	-	-	ns	DIN[23:0] to CLKIN
DEN setup time	T _{esd}	12	-	-	ns	DEN to CLKIN
Time that VSD to 1 st line data input	T _{vs}	2	13	127	Th	@CCIR601 / 8bit RGB HV mode Control by HDLY[6:0] setting T _{vs} = HDLY[6:0]
Time that CCIR_V to 1 st line data input	T _{vs}	12	20	28	Th	@CCIR656 NTSC mode Control by HDLY[6:0] setting T _{vs} = HDLY[6:0]
Time that CCIR_V to 1 st line data input	T _{vs} 17 25 33 Th					@CCIR656 PAL mode Control by HDLY[6:0] setting T _{vs} = HDLY[6:0]
Time that VSD to 1 st line data input	T _{vs}	2	13	127	Th	@24bit RGB HV mode Control by HDLY[6:0] setting T _{vs} = HDLY[6:0]
Source output stable time 1	T _{st}	-	25	30	us	96% final, CL=30pF, RL=2K
Gate output stable time	T _{gst}	-	500	1000	ns	96% final, CL=40pF
VCOMOUT output stable time	T _{cst}	-	4	8	us	96% final, CL=33nF, RL=100ohm
3-wire serial communication AC timing						
Serial clock	T _{spck}	320	-	-	ns	
SPCK pulse duty		40	50	60	%	T _{ckh} / T _{spck}
Serial data setup time	T _{isu}	120	-	-	ns	
Serial data hold time	T _{ihd}	120	-	-	ns	
Serial clock high/low	T _{ckh/l}	120	-	-	ns	
Chip select distinguish	T _{cd}	1	-	-	us	
SPENB to VSD	T _{cv}	1	-	-	us	
SPENB input setup time	T _{eck}	150	-	-	ns	
SPENB input hold time	T _{cke}	150	-	-	ns	

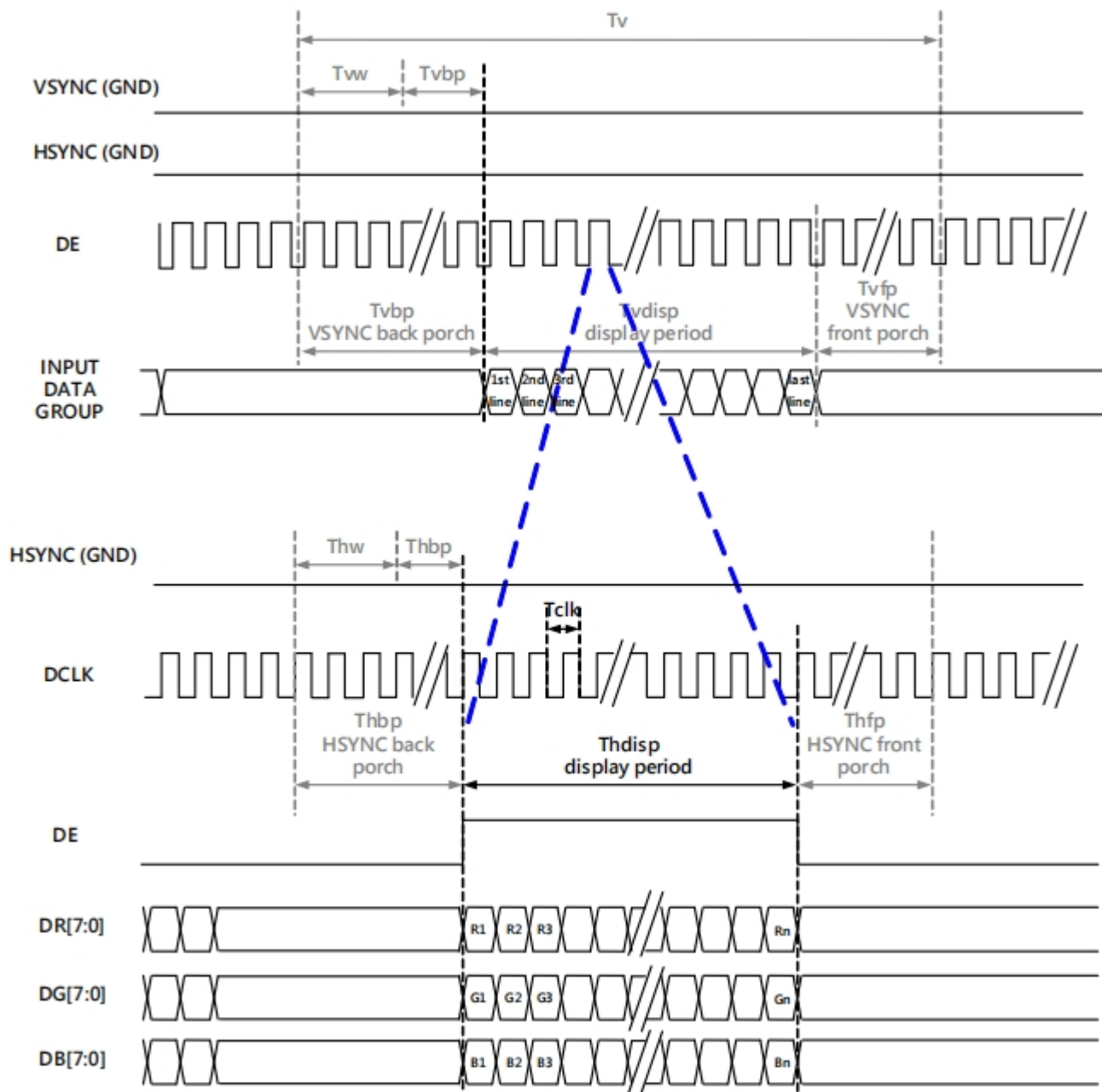

Parallel RGB DE Mode

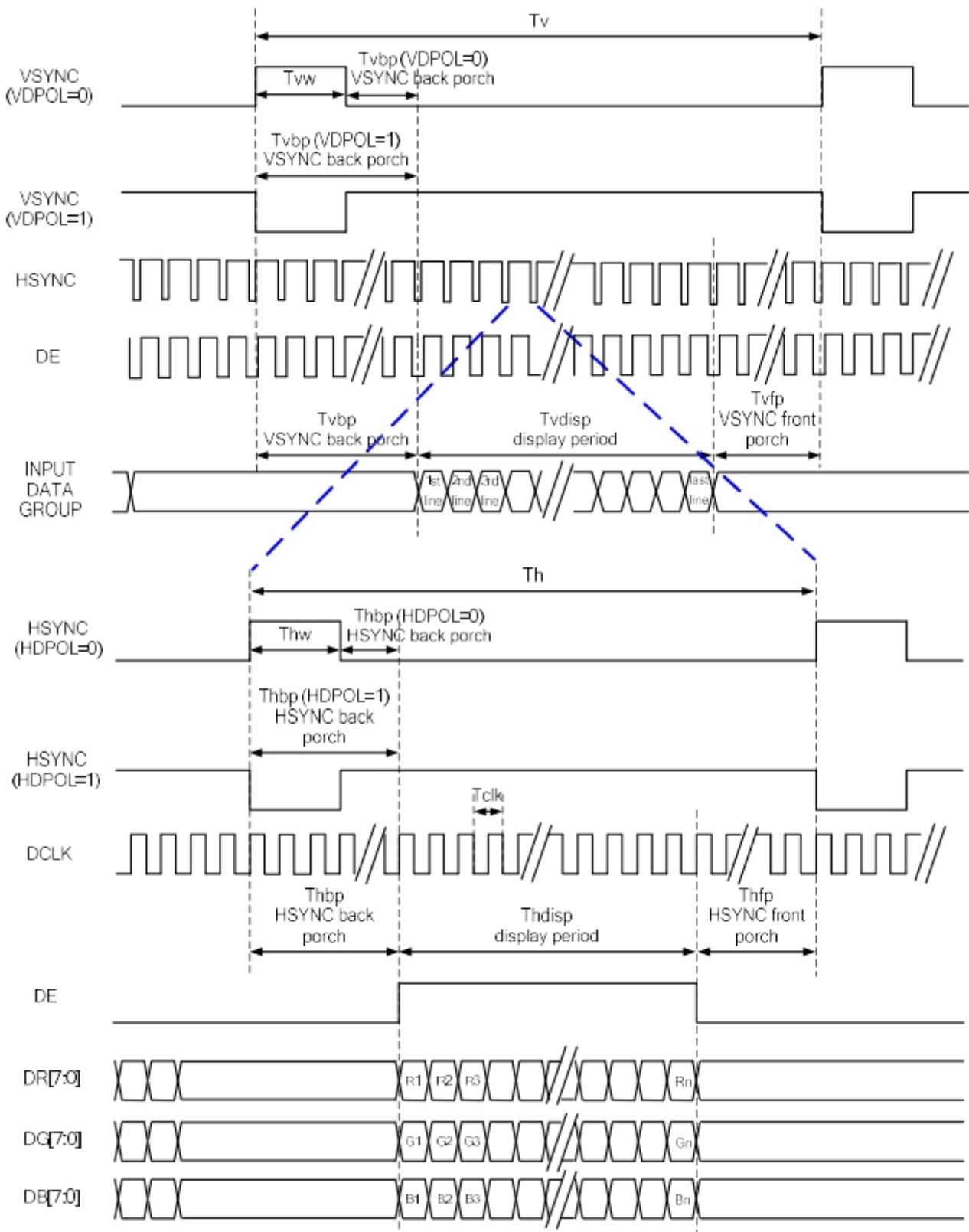

Parallel RGB SYNC-DE Mode

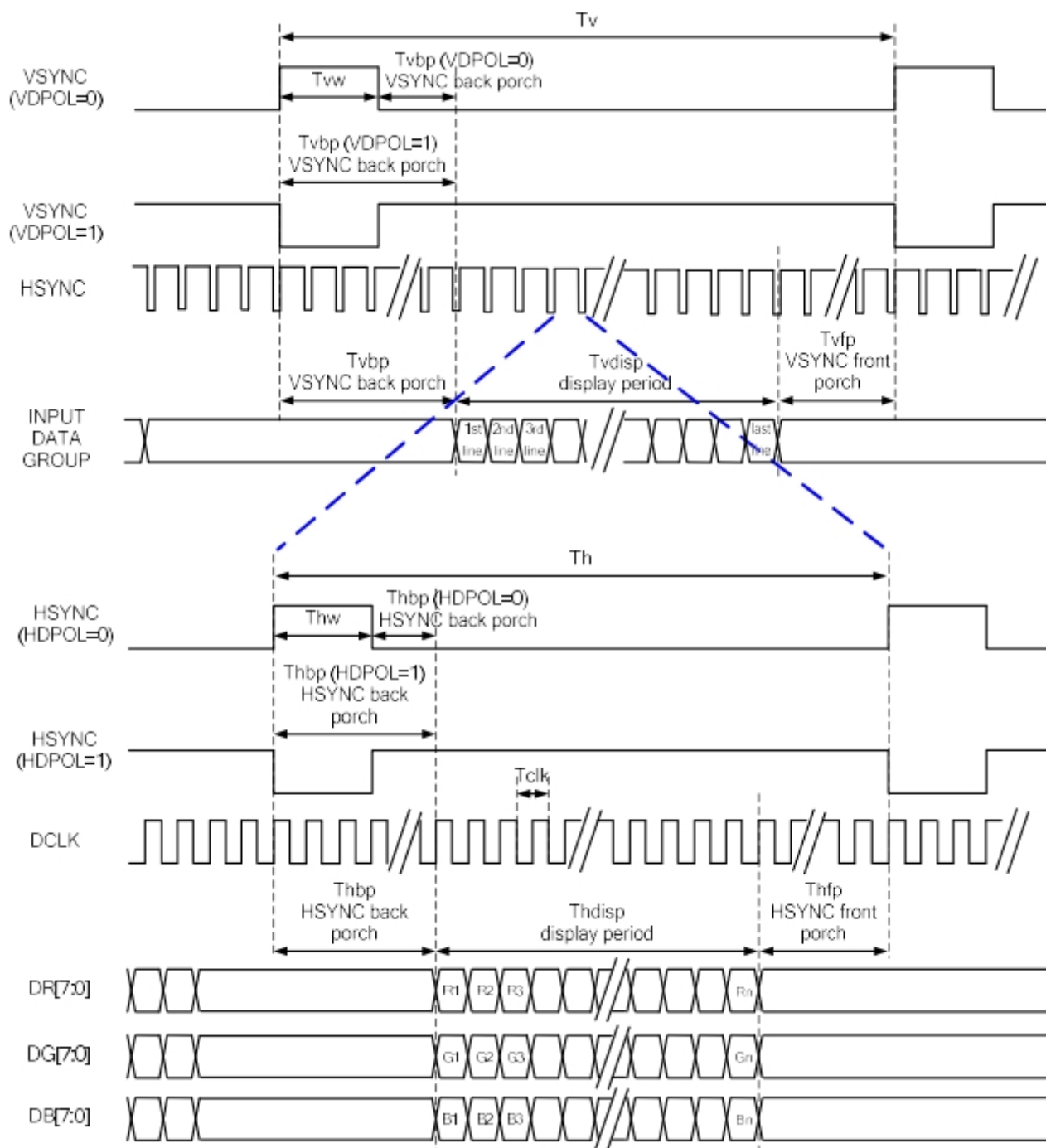

Parallel RGB SYNC Mode

Parallel 24-bit RGB Input Timing Table							
Item	Symbol	Min.	Typ.	Max.	Unit	Note	
DCLK Frequency	Fclk	5	6	8	MHz		
DCLK Period	Tclk	125	167	200	ns		
HSYNC	Period Time	Th	325	371	438	DCLK	
	Display Period	Thdisp		320		DCLK	
	Back Porch	Thbp	3	43	43	DCLK	SYNC mode back porch control by H_BLANKING[7:0] setting Thbp= H_BLANKING[7:0]
	Front Porch	Thfp	2	8	75	DCLK	
	Pulse Width	Thw	2	4	43	DCLK	
VSYNC	Period Time	Tv	244	260	289	HSYNC	
	Display Period	Tvdisp		240		HSYNC	
	Back Porch	Tvbp	2	12	12	HSYNC	SYNC mode back porch control by V_BLANKING[7:0] setting Tvbp= V_BLANKING[7:0]
	Front Porch	Tvfp	2	8	37	HSYNC	
	Pulse Width	Tvw	2	4	12	HSYNC	

Note: It is necessary to keep Tvbp =12 and Thbp =43 in sync mode. DE mode is unnecessary to keep it.

Parallel RGB Input Timing Table

6.2 DC Characteristics

Recommended Operating Range

Item	Symbol	Min.	Typ.	Max.	Unit	Conditions
Supply Voltage	VDD	3.0	3.3	3.6	V	
IO Supply Voltage	VDDI	3.0	-	3.6	V	
Charge Pump Supply Voltage	PVDD	3.0	3.3	3.6	V	

DC Characteristics for Digital Circuit

Item	Symbol	Min.	Typ.	Max.	Unit	Conditions
Logic-High Input Voltage	Vih	0.7VDDI	-	VDDI	V	
Logic-Low Input Voltage	Vil	DGND	-	0.3VDDI	V	
Logic-High Output Voltage	Voh	VDDI-0.4	-	VDDI	V	
Logic-Low Output Voltage	Vol	DGND	-	DGND+0.4	V	

DC Characteristics for Analog Circuit

Item	Symbol	Min.	Typ.	Max.	Unit	Conditions
Positive High-Voltage Power	VGH	13	15	16.5	V	No Load@ FR=60Hz
Negative High-Voltage Power	VGL	-7	-10	-11	V	
Output Voltage Deviation	Vod	-	±35	±45	mV	
Standby Current	Isc	-		50	uA	
Operation Current	Ioc	-	20		mA	

6.3 Power On/Off Sequence

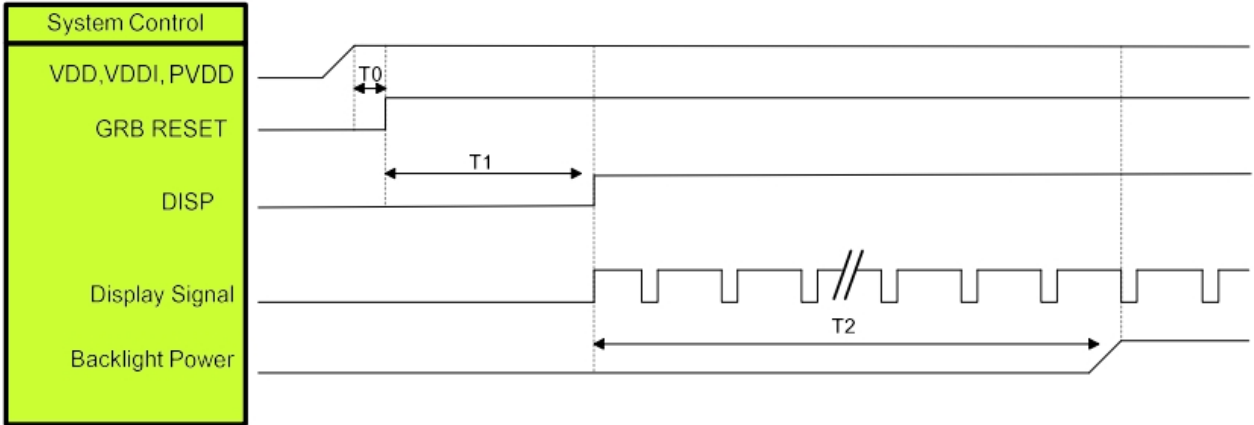

Symbol	Description	Min. Time	Unit
T0	System power stability to GRB RESET signal	0	ms
T1	GRB RESET= "High" to DISP="High"	10	ms
T2	Display Signal output to Backlight Power on	250	ms

Note: Display signal: DCLK; VSYNC; HSYNC; DE; DR[7:0]; DG[7:0]; DB[7:0]

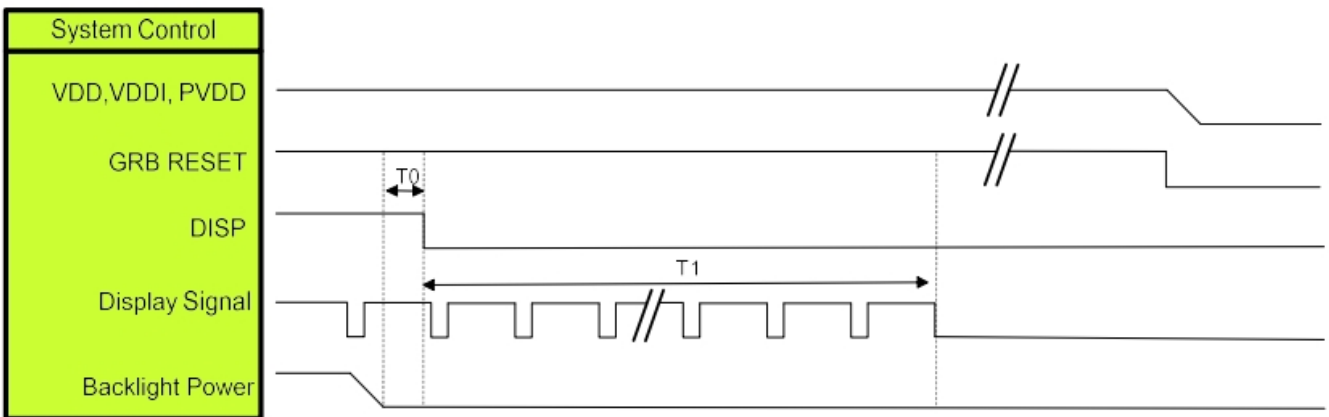

Symbol	Description	Min. Time	Unit
T0	Backlight Power off to DISP="Low"	5	ms
T1	DISP="Low" to IC internal voltage discharge complete	80	ms

Note: Display signal: DCLK; VSYNC; HSYNC; DE; DR[7:0]; DG[7:0]; DB[7:0]

7. Optical Characteristics

Items	Symbol	Condition	Min.	Typ.	Max.	Unit	Remark	
Viewing Angles	θ_T	Center	-	80	-	Degree.	Note2	
	θ_B		-	80	-			
	θ_L		-	80	-			
	θ_R		-	80	-			
Contrast Ratio	CR	$\Theta = 0$	640	800	-	-	Note1, Note3	
Response Time	$T_{ON}+T_{off}$	25° C	-	30	40	ms	Note1, Note4	
Chromaticity	White	X_W	Backlight is on	0.267	0.317	0.367	-	Note1, Note5
		Y_W		0.289	0.339	0.389	-	
	Red	X_R		0.596	0.646	0.696	-	
		Y_R		0.282	0.332	0.382	-	
	Green	X_G		0.273	0.323	0.373	-	
		Y_G		0.517	0.567	0.617	-	
	Blue	X_B		0.084	0.134	0.184	-	
		Y_B		0.071	0.121	0.171	-	
NTSC				60		%	Note5	
Luminance	LV		250	300	-	cd/m2	Note1, Note7	
Luminance Uniformity	Yu	$\theta = 0^\circ$	80	85	-	%	FIG.2	

Test Conditions:

1. IF= 20mA (one channel), the ambient temperature is 25°C
2. The test systems refer to Note 1 and Note 2.

Note 1: Definition of optical measurement system.

The optical characteristics should be measured in dark room. After 5 minutes operation, the optical properties are measured at the center point of the LCD screen. All input terminals LCD panel must be ground when measuring the center area of the panel.

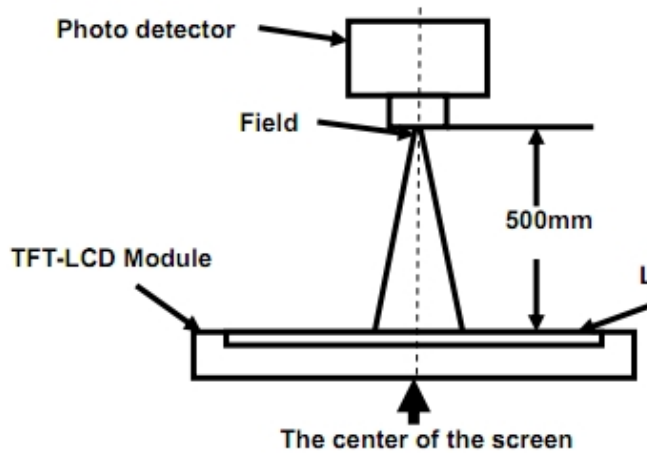

Item	Photo detector	Field
Contrast Ratio	SR-3A	1°
Luminance		
Chromaticity		
Lum Uniformity		
Response Time	BM-7A	2°

Note 2: Definition of viewing angle range and measurement system.

viewing angle is measured at the center point of the LCD by CONOSCOPE(ergo-80).

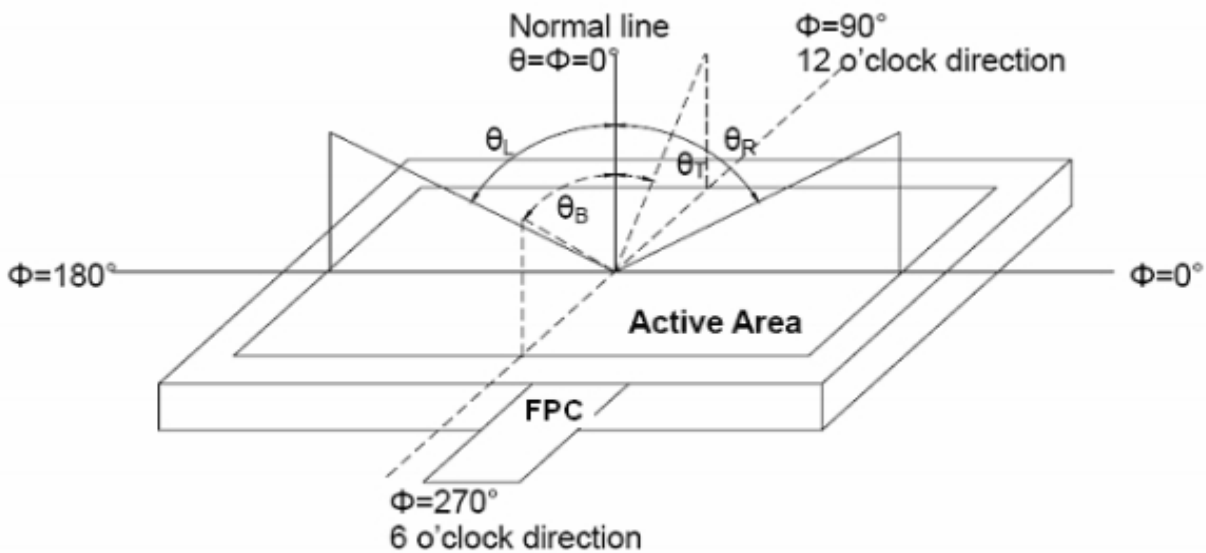

Fig. 1 Definition of viewing angle

Note 3: Definition of contrast ratio

$$\text{Contrast ratio (CR)} = \frac{\text{Luminance measured when LCD is on the "White" state}}{\text{Luminance measured when LCD is on the "Black" state}}$$

“White state “:The state is that the LCD should driven by Vwhite.

“Black state”: The state is that the LCD should driven by Vblack.

Vwhite: To be determined Vblack: To be determined.

Note 4: Definition of Response time

The response time is defined as the LCD optical switching time interval between “White” state and “Black” state. Rise time (TON) is the time between photo detector output intensity changed from 90% to 10%. And fall time (TOFF) is the time between photo detector output intensity changed from 10% to 90%.

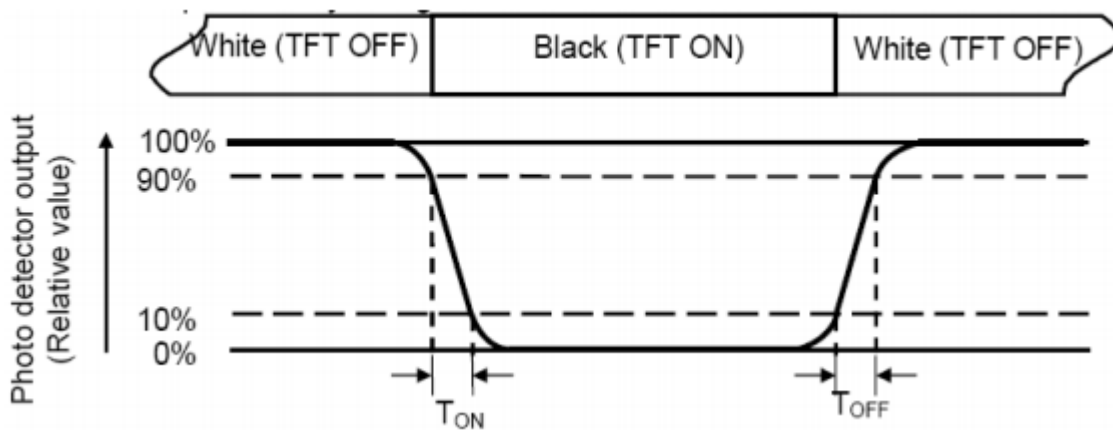

Note 5: Definition of color chromaticity (CIE1931)

Color coordinates measured at center point of LCD.

Note 6: Definition of Luminance Uniformity

Active area is divided into 9 measuring areas (Refer Fig. 2). Every measuring point is placed at the center of each measuring area.

$$\text{Luminance Uniformity}(U) = L_{\min} / L_{\max}$$

L-----Active area length W----- Active area width

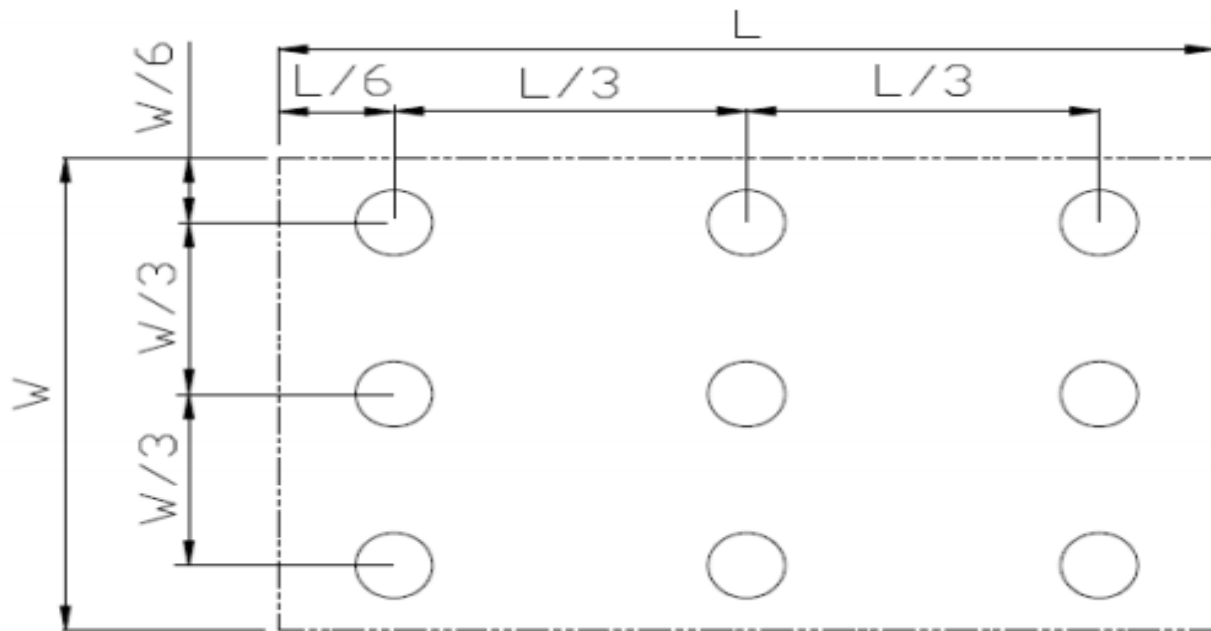

Fig. 2 Definition of uniformity

Lmax: The measured maximum luminance of all measurement position.

Lmin: The measured minimum luminance of all measurement position.

Note 7: Definition of Luminance :

Measure the luminance of state at point.

8. Environmental / Reliability Tests

No	Test Item	Condition	Remarks
1	High Temperature Operation	Ts= +70°C, 96hrs	IEC60068-2-1:2007 GB2423. 2-2008
2	Low Temperature Operation	Ta= -20°C, 96hrs	IEC60068-2-1:2007 GB2423.1-2008
3	High Temperature Storage	Ta= +80°C,96hrs	IEC60068-2-1:2007 GB2423. 2-2008
4	Low Temperature Storage	Ta= -30°C, 96hrs	IEC60068-2-1:2007 GB2423.1-2008
5	High Temperature & Humidity Operation	Ta= +60°C, 90% RH max,96 hours	IIEC60068-2-78:2001 GB/T2423.3-2006
6	Thermal Shock (Non-operation)	-30°C 30 min ~ +80°C 30 min Change time: 5min, 20 Cycle	Start with cold temperature, end with high temperature IEC60068-2-14:1984,G B2423.22-2002
7	ESD	C=150pF, R=330 Ω, 5 points/panel , Air:±8KV, 5 times Contact: ±4KV, 5 times (Environment: 15°C ~ 35°C, 30% ~ 60%, 86Kpa ~ 106Kpa)	IEC61000-4-2:2001 GB/T17626.2-2006
8	Vibration (Non-operation)	Frequency range: 10~55Hz, Stroke: 1.5mm , Sweep: 10Hz~55Hz~10Hz 2 hours for each direction of X .Y. Z. (6 hours for total)	IEC60068-2-6:1982 GB/T2423.10-1995
9	Mechanical Shock (Non-operation)	Half Sine Wave 60G ,6ms,±X,±Y,±Z 3times for each direction	IEC60068-2-27:1987 GB/T2423.5—1995
10	Package Drop Test	Height: 60 cm, 1 corner, 3 edges, 6 surfaces	IEC60068-2-32:1990 GB/T2423.8-1995

Notes:

1. The test result shall be evaluated after the sample has been left at room temperature and humidity for 2 hours without load. No condensation shall be accepted.
The sample will not be accepted if appear these defects:
 - Air bubble in the LCD
 - Seal leak
 - Non-display
 - Missing segments
 - Glass crack
 - CR reduction >40%
 - IDD increase >100%
 - Brightness reduction >50%
 - Color coordinate tolerance >0.05
2. ≤ 7.0 inch: The size of sample is 5pcs;
 > 7.0 inch: The size of sample is 2pcs;
3. One test sample must complete each test item;
4. In case of malfunction defect caused by ESD damage, if it would be recovered to normal state after resetting, it would be judge as a good part.
5. In the test of High Temperature Operation and High Temperature & Humidity Operation, the operation temperature is the surface temperature of module.

9. Mechanical Drawing

6	X1(XR)
7	NC
8	RESET
9	CS
10	SCL
11	SDA
12	SDO
13	NC
14	B0
15	B1
16	B2
17	B3
18	B4
19	B5
20	NC
21	NC
22	G0
23	G1
24	G2
25	G3
26	G4
27	G5
28	NC
29	NC
30	R0
31	R1
32	R2
33	R3
34	R4
35	R5
36	HSYNC
37	VSYNC
38	DOTCLK
39	GND
40	OVCC
41	VDD
42	VDD
43	Y2(YD)
44	X2(XL)
45	NC
46	NC
47	NC
48	NC
49	NC
50	NC
51	NC
52	BEN
53	GND
54	GND

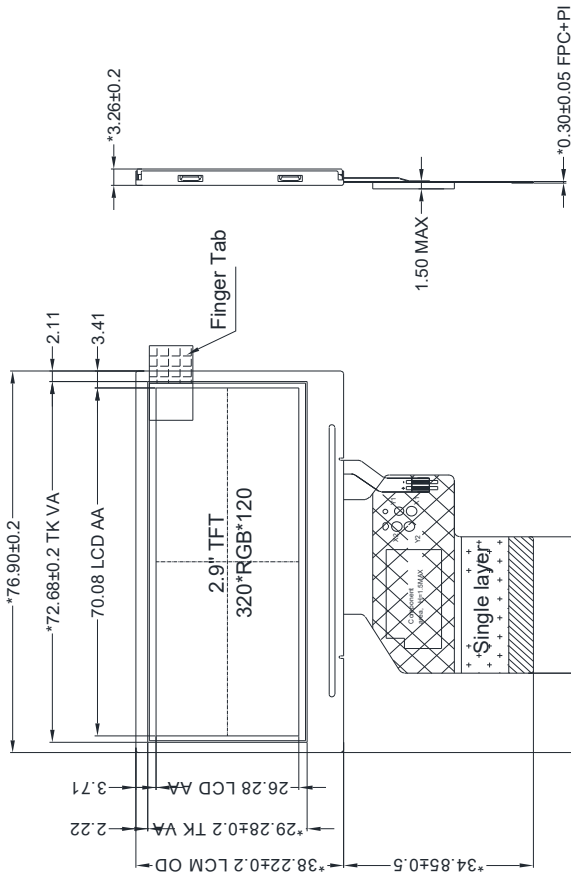
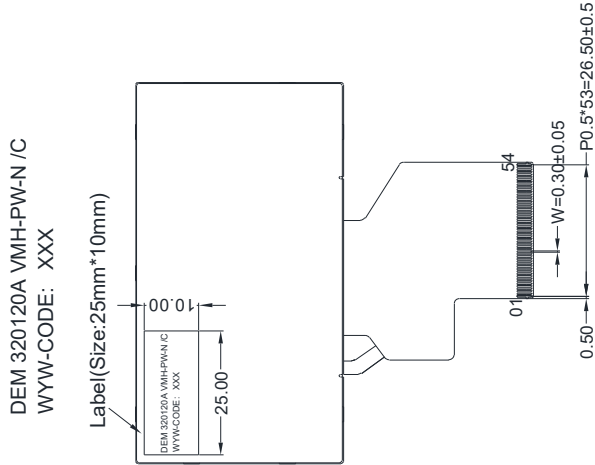

AC — — OK

LED CIRCUIT DIAGRAM

LCM NOTES:

1. DISPLAY TYPE: 2.9 INCH TFT / TRANSMISSIVE
2. BACKLIGHT: 6 CHIP WHITE LED, 6S
VF = 19.2±1.6V, IF = 20mA
3. OPERATING TEMP: -20°C ~ +70°C
4. STORAGE TEMP: -30°C ~ +80°C
5. LCD IC: TBD
6. Luminance: 300cd/m²(TYP)
7. *) Reference dimension; ** critical dimension
8. RoHS Compliant

10. Precautions For Use of LCD modules

10.1 Handling Precautions

- 10.1.1. The display panel is made of glass. Do not subject it to a mechanical shock by dropping it from a high place, etc.
- 10.1.2. If the display panel is damaged and the liquid crystal substance inside it leaks out, be sure not to get any in your mouth, if the substance comes into contact with your skin or clothes, promptly wash it off using soap and water.
- 10.1.3. Do not apply excessive force to the display surface or the adjoining areas since this may cause the color tone to vary.
- 10.1.4. The polarizer covering the display surface of the LCD module is soft and easily scratched. Handle this polarizer carefully.
- 10.1.5. If the display surface is contaminated, breathe on the surface and gently wipe it with a soft dry cloth. If still not completely clear, moisten cloth with one of the following solvents:
 - Isopropyl alcohol
 - Ethyl alcoholSolvents other than those mentioned above may damage the polarizer. Especially, do not use the following:
 - Water
 - Ketone
 - Aromatic solvents
- 10.1.6. Do not attempt to disassemble the LCD Module.
- 10.1.7. If the logic circuit power is off, do not apply the input signals.
- 10.1.8. To prevent destruction of the elements by static electricity, be careful to maintain an optimum work environment.
 - 10.1.8.1. Be sure to ground the body when handling the LCD Modules.
 - 10.1.8.2. Tools required for assembly, such as soldering irons, must be properly ground.
 - 10.1.8.3. To reduce the amount of static electricity generated, do not conduct assembly and other work under dry conditions.
 - 10.1.8.4. The LCD Module is coated with a film to protect the display surface.
Be care when peeling off this protective film since static electricity may be generated.

10.2 Storage Precautions

- 10.2.1. When storing the LCD modules, avoid exposure to direct sunlight or to the light of fluorescent lamps.
- 10.2.2. The LCD modules should be stored under the storage temperature range.
If the LCD modules will be stored for a long time, the recommend condition is:
Temperature: 0°C ~ 40°C Relatively humidity: ≤80%
- 10.2.3. The LCD modules should be stored in the room without acid, alkali and harmful gas.

10.3 Inspection Sampling

- 10.3.1. Lot size: Quantity per shipment lot per model
- 10.3.2. Sampling type: Normal inspection, Single sampling
- 10.3.3. Inspection level: II
- 10.3.4. Sampling table: MIL-STD-105D
- 10.3.5. Acceptable quality level (AQL)
 - Major defect: AQL=0.65
 - Minor defect: AQL=1.00

10.4 Inspection Conditions

- 10.4.1 Ambient conditions:
 - a. Temperature: Room temperature $25^{\circ}\text{C} \pm 5^{\circ}\text{C}$
 - b. Humidity: $(60\% \pm 10\%)$ %RH
 - c. Illumination: Single fluorescent lamp non-directive (300 to 700 Lux)
- 10.4.2 Viewing distance
The distance between the LCD and the inspectors eyes shall be at least $35\text{cm} \pm 5 \text{ cm}$.
- 10.4.3 Viewing Angle
U/D: 45o/45o, L/R: 45o/45o

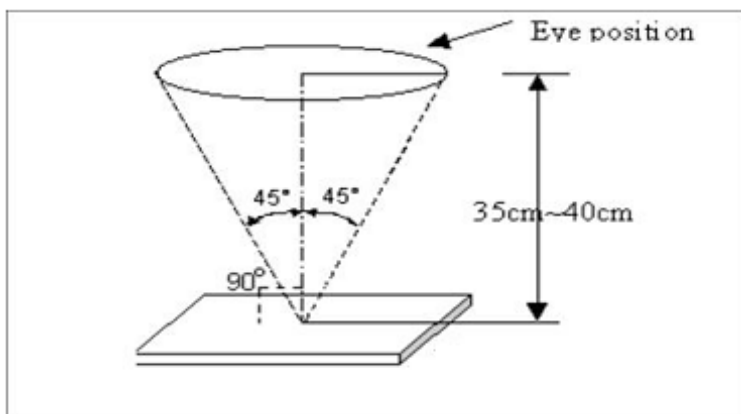

10.5. Inspection Criteria

Defects are classified as major defects and minor defects according to the degree of Defectiveness defined herein.

10.5.1 Major defect

Item No	Items to be inspected	Inspection Standard
10.5.1.1	All functional defects	1) No display 2) Display abnormally 3) Short circuit 4) line defect
10.5.1.2	Missing	Missing function component
10.5.1.3	Crack	Glass Crack

10.5.2 Minor defect

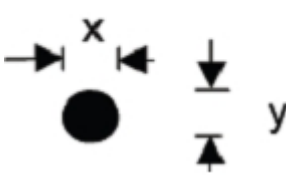
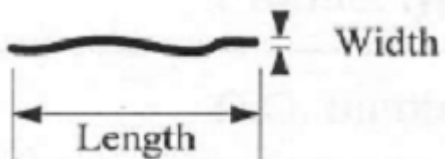
Item No	Items to be inspected	Inspection standard								
10.5.2.1	Spot Defect Including Black spot White spot Pinhole Foreign particle Polarizer dirt	For dark/white spot is defined $\varphi = (x+y) / 2$ 								
		<table border="1"> <thead> <tr> <th>Size φ(mm)</th> <th>Acceptable Quantity</th> </tr> </thead> <tbody> <tr> <td>$\varphi \leq 0.2$</td> <td>Ignore</td> </tr> <tr> <td>$0.2 < \varphi \leq 0.3$</td> <td>3</td> </tr> <tr> <td>$0.3 < \varphi$</td> <td>Not allowed</td> </tr> </tbody> </table>	Size φ (mm)	Acceptable Quantity	$\varphi \leq 0.2$	Ignore	$0.2 < \varphi \leq 0.3$	3	$0.3 < \varphi$	Not allowed
		Size φ (mm)	Acceptable Quantity							
		$\varphi \leq 0.2$	Ignore							
		$0.2 < \varphi \leq 0.3$	3							
$0.3 < \varphi$	Not allowed									
10.5.2.2	Line Defect Including Black line White line Scratch	Define: 								
		<table border="1"> <thead> <tr> <th>Width(mm) Length(mm)</th> <th>Acceptable Quantity</th> </tr> </thead> <tbody> <tr> <td>$W \leq 0.05$</td> <td>Ignore</td> </tr> </tbody> </table>	Width(mm) Length(mm)	Acceptable Quantity	$W \leq 0.05$	Ignore				
		Width(mm) Length(mm)	Acceptable Quantity							
$W \leq 0.05$	Ignore									

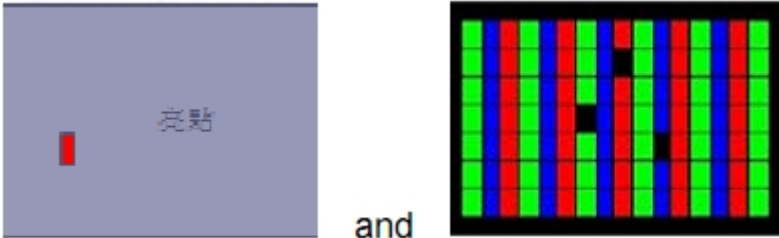
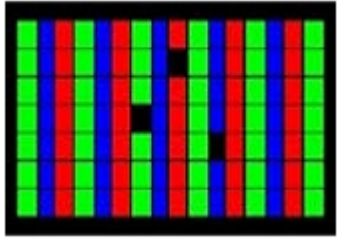
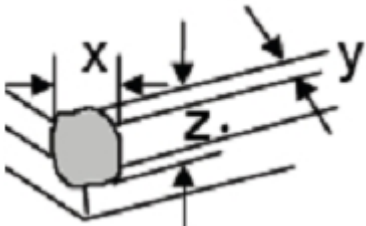
		$0.05 < W \leq 0.1$ $L \leq 2.5$	3	
		$0.1 < W, \text{ or } L > 2.5$	Not allowed	
10.5.2.3	Polarizer Dent/Bubble	Size ϕ (mm)	Acceptable Quantity	
		$\phi \leq 0.2$	Ignore	
		$0.2 < \phi \leq 0.3$	2	
		$0.3 < \phi \leq 0.5$	1	
		$0.5 < \phi$	Not allowed	
		Total QTY	3	
		10.5.2.4	Electrical Dot Defect	Bright and Black dot define:
				
and				
				
Two Adjacent Dot				
Inspection pattern: Full white、 Full black、 Red、 green and blue screens				
Item	Acceptable Quantity			
	I O Note			
Black dot defect	2			(5mm \leq Distance)
Bright dot defect	1			
Two Adjacent Dot	1			
There or more Adjacent Dot	Not allowed			
Total Dot	2			
10.5.2.5	Glass defect			
		1. Corner Fragment:		
		Size(mm)	Acceptable Quantity	
		$X \leq 3\text{mm}$ $Y \leq 1\text{mm}$	Ignore T: Glass thickness	

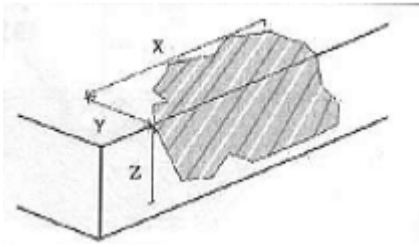
		$Z \leq T$	X: Length Y: Width Z: thickness
		 <p>2. Side Fragment:</p>	
		Size(mm)	Acceptable Quantity
		$X \leq 5.0\text{mm}$ $Y \leq 1\text{mm}$ $Z \leq T$	T: Glass thickness X: Length Y: Width Z: thickness

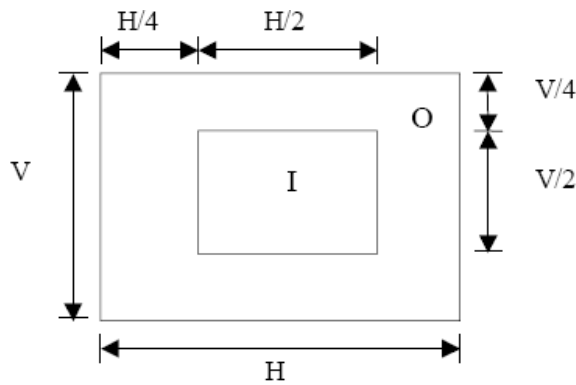

I area & O area

- Note:
- 1). Dot defect is defined as the defective area of the dot area is larger than 50% of the dot area.
 - 2). The distance between two bright dot defects (red, green, blue, and white) should be larger than 15mm.
 - 3). The distance between black dot defects or black and bright dot defects should be more than 5mm apart.
 - 4). Polarizer bubble is defined as the bubble appears on active display area. The defect of polarizer bubble shall be ignored if the polarizer bubble appears on the outside of active display area.

10.6 Mechanics specification

As for the outside dimension of the modules, please refer to product specification for more details

- Note:
- 1). Dot defect is defined as the defective area of the dot area is larger than 50% of the dot area.
 - 2) The distance between two bright dot defects (red, green, blue, and white)

11. Precautions for Use of LCD modules

11.1 Handling Precautions

- 11.1.1. The display panel is made of glass. Do not subject it to a mechanical shock by dropping it from a high place, etc.
- 11.1.2. If the display panel is damaged and the liquid crystal substance inside it leaks out, be sure not to get any in your mouth, if the substance comes into contact with your skin or clothes, promptly wash it off using soap and water.
- 11.1.3. Do not apply excessive force to the display surface or the adjoining areas since this may cause the color tone to vary.
- 11.1.4. The polarizer covering the display surface of the LCD module is soft and easily scratched. Handle this polarizer carefully.
- 11.1.5. If the display surface is contaminated, breathe on the surface and gently wipe it with a soft dry cloth. If still not completely clear, moisten cloth with one of the following solvents:
 - Isopropyl alcohol
 - Ethyl alcoholSolvents other than those mentioned above may damage the polarizer. Especially, do not use the following:
 - Water
 - Ketene
- 11.1.6. Do not attempt to disassemble the LCD Module.
- 11.1.7. If the logic circuit power is off, do not apply the input signals.
- 11.1.8. To prevent destruction of the elements by static electricity, be careful to maintain an optimum work environment.
 - 11.1.8.1. Be sure to ground the body when handling the LCD Modules.
 - 11.1.8.2. Tools required for assembly, such as soldering irons, must be properly ground.
 - 11.1.8.3. To reduce the amount of static electricity generated, do not conduct assembly and other work under dry conditions.
 - 11.1.8.4. The LCD Module is coated with a film to protect the display surface. Be care when peeling off this protective film since static electricity may be generated.

11.2 Storage Precautions

11.2.1. When storing the LCD modules, avoid exposure to direct sunlight or to the light of fluorescent lamps.

11.2.2. The LCD modules should be stored under the storage temperature range. If the LCD modules will be stored for a long time, the recommend condition is:

Temperature: 0°C ~ 40°C Relatively Humidity: ≤80%

11.2.3. The LCD modules should be stored in the room without acid, alkali and harmful gas.

11.3 Transportation Precautions

The LCD modules should be no falling and violent shocking during transportation, and also should avoid excessive press, water, damp and sunshine.

X-ON Electronics

Largest Supplier of Electrical and Electronic Components

Click to view similar products for [TFT Displays & Accessories](#) category:

Click to view products by [Display Elektronik](#) manufacturer:

Other Similar products are found below :

[F3ET2-005-150](#) [HDA430T-3G1H](#) [NB7W-KBA04](#) [NB-ATT01](#) [NB5Q-ATT01](#) [NB5Q-KBA04](#) [NB-CN001](#) [OAI-80038AA-2008-A](#) [315-U004B15300](#) [TCG121WXLRXVNNANX35](#) [EIC-LCD-1080P](#) [T-55619GD065J-LW-ABN](#) [NLB150XG02L-01](#) [NL192108AC10-01D](#) [NL6448AC18-08F](#) [NL8060BC26-35BA](#) [NL6448BC26-26D](#) [NL8060BC31-50F](#) [TM070DDHG03-40](#) [PTPW16-070WV1S02](#) [PTPW16-084SV1S02](#) [MTD0300ECP06DF-1](#) [4DLCD-35480320-CTP-IPS](#) [4DLCD-35480320-IPS](#) [4DLCD-35480320-RTP-IPS](#) [4DLCD-50800480-CTP-IPS](#) [RFA6400E-AWH-DNG](#) [RFE430V-AZW-DNS](#) [RFF70BQ-1IW-DBG](#) [RFF70VA2-1IW-DHS](#) [RFH700A8-AYH-MNN](#) [RFK101VF-1YH-LHG](#) [RFS52VA-1ZH-DHN](#) [SM-RVT101HVHFWN00](#) [SM-RVT101HVHNWC00](#) [SM-RVT101HVHNWCA0](#) [SM-RVT101HVHNWN00](#) [SM-RVT101HVLFWCA0](#) [SM-RVT101HVLNWCA0](#) [SM-RVT35HHTFWCA0](#) [SM-RVT35HHTNWCA0](#) [SM-RVT43HLTFWCA0](#) [SM-RVT43HLTNWCA0](#) [SM-RVT50HQTFWCA0](#) [SM-RVT50HQTNWCA0](#) [SM-RVT70AQLFWR00](#) [SM-RVT70AQLNWR00](#) [SM-RVT70HSLFWCA0](#) [SM-RVT70HSMFWCA0](#) [SM-RVT70HSMFWN00](#)