

# Projected Capacitive Touch Panel Product Specification

**DT028A-PTS**  
2.8" PCAP

June 22, 2015

**Remark:**

Contents in this document are subject to change without notice. No part of this document may be reproduced or transmitted in any form or by any means, electronic or mechanical, for any purpose, without the express written permission of Displaytech Ltd.

**Displaytech Ltd.**

Tel: (852) 2311 2080 ; Fax: (852) 2722 6998 ; Email: [sales@displaytech.com.hk](mailto:sales@displaytech.com.hk)

Address: 31E Billion Plaza 2, No. 10 Cheung Yue Street, Cheung Sha Wan, Kowloon,  
Hong Kong.

Website: <http://www.displaytech.com.hk>

## 1. Revision Record

<b>REV</b>	<b>CHANGES</b>	<b>DATE</b>
0.0 (Ref. A1 20130409)	First release	Jun 22, 2015

## Table of Content

<b>1.</b>	<b>Revision Record.....</b>	<b>1</b>
<b>2.</b>	<b>Specifications and Structure.....</b>	<b>3</b>
	2.1 Structure & dimensions.....	3
	2.2 Specifications & Features .....	3
	2.3 Structure & Mechanical drawing.....	4
<b>3.</b>	<b>Properties .....</b>	<b>5</b>
	3.1 Operation and storage conditions .....	5
	3.2 Electrical properties.....	5
	3.3 Mechanical properties .....	5
	3.4 Optical properties.....	5
<b>4.</b>	<b>Appearance Inspections.....</b>	<b>5</b>
	4.1 Inspection level .....	5
	4.2 Inspection area & conditions .....	6
	4.3 Inspection Criteria (within VA) .....	6
<b>5.</b>	<b>Reliability Test.....</b>	<b>9</b>
	5.1 Environmental tests .....	9
	5.2 Durability Test .....	10
	5.3 FPC FPC reliability tests.....	10
<b>6.</b>	<b>Precautions .....</b>	<b>11</b>
	6.1 Inspection Information.....	12
	6.2 Maintenance and Precaution.....	12
	6.3 Product warranty.....	12
<b>7.</b>	<b>Drawings, Toolings, Testing Fixtures and Information.....</b>	<b>13</b>

## 2. Specifications and Structure

This is a projected capacitive touch panel with below specifications.

### 2.1 Structure & dimensions

Item	Specifications & Dimension
Product type	Projected capacitive touch panel
Structure	Cover glass + LOCA+ Sensor glass + COF
Cover Lens	No cover lens
Sensor glass (OD)	50.00 x 69.20 mm
View Area (VA)	45.20 x 59.60 mm
Active Area (AA)	44.20 x 58.60 mm

### 2.2 Specifications & Features

Touch controller	GT968
Support multi-touch	2 fingers
Capacitive sensing method	Mutual capacitive
Operation voltage	3.3V (IO 1.8V)
Interrupt	Pull low pulse
Interface	I2C (Max. 400K bps @ 12Mhz)
I2C Address	0xBA/0xBB
Resolution	240 x 320
Report rate(max)	100Hz@1 finger; 60Hz@5 fingers
Sensitivity	Ø 5mm copper rod
Touch precision	≤1mm@center; ≤1.5mm@peripheral
Linearity	≤±1mm
2 points min. distance	≥12mm
Firmware	DBG-02V2.4.120920.bin

2.3 Structure & Mechanical drawing

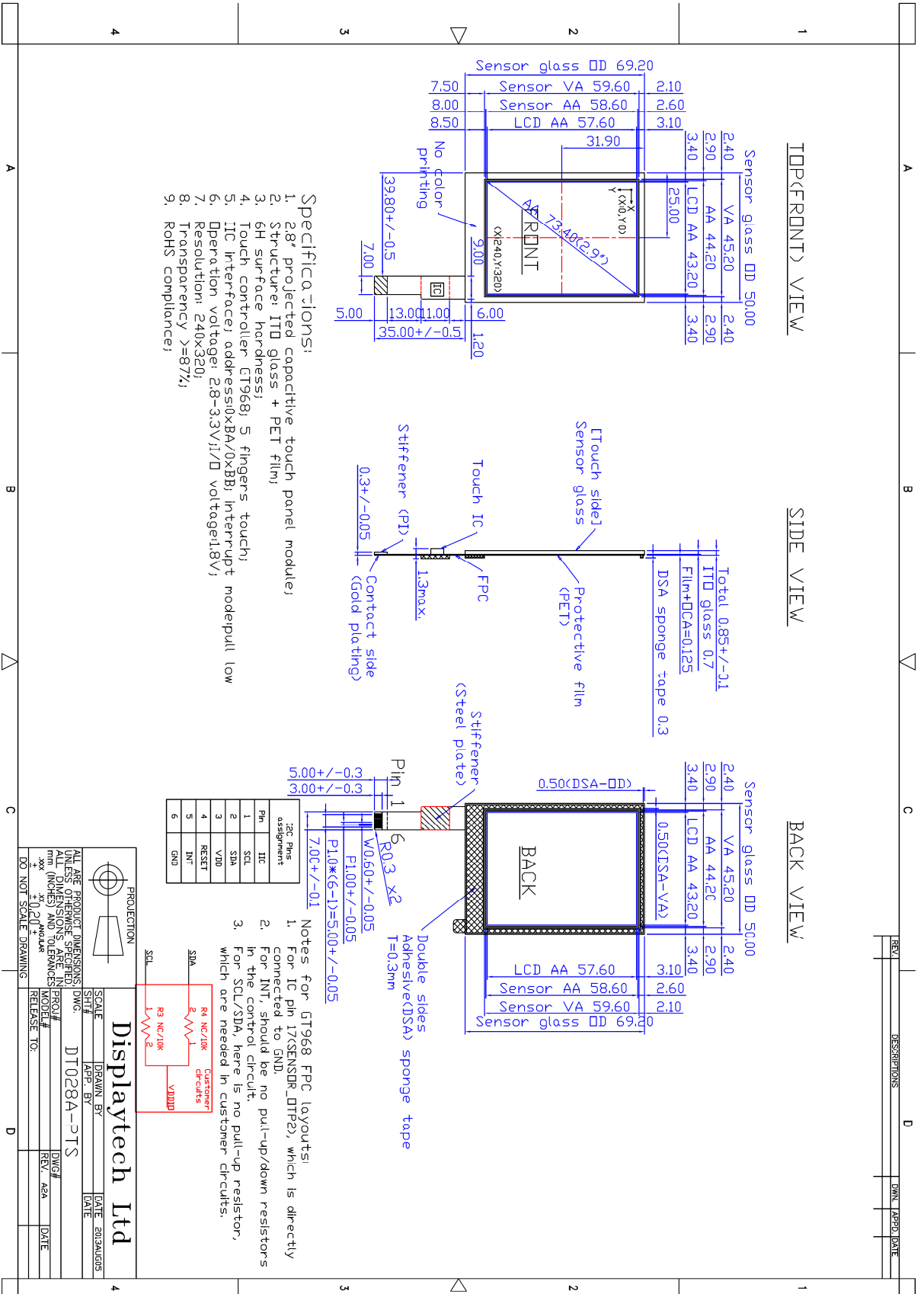

### 3. Properties

#### 3.1 Operation and storage conditions

Item	Conditions
Operation Temp & Humidity	-10°C ~ +60°C; RH: 20~85% (no dew condensation)
Storage Temp & Humidity	-20°C ~ +70°C; RH: 20~85% (no dew condensation)

#### 3.2 Electrical properties

Item		Specifications		
		Min	Typ	Max
<b>Ta=25oC; 1 atmosphere</b>				
Operating Voltage (VDD) (Ripple voltage <100mV)		2.8V	3.3V	3.6V
I/O operation voltage		1.8V	3.3V	3.6V
Flash operation voltage		2.8V	3.3V	3.6V
Current (VDD= 3.3V)	Active mode 1 finger touch (report rate 100Hz): 5 fingers touch (report rate 60Hz):	---	TBD	TBD
	Idle mode (Report rate 100Hz)	---	TBD	TBD
	Sleep mode	---	TBD	TBD
Insulation resistance (@DC 25 V)		20MΩ	---	---
ESD (HBM model)		---	Contact TBD	Air TBD

#### 3.3 Mechanical properties

Input mode	Finger or capacitive stylus
Surface hardness	6H
Writing Durability	Over 1,000,000times
Hitting Durability	Over 10,000,000times

#### 3.4 Optical properties

Total light transmittance	≥ 85%(typ.)
Haze	≤ 1%(typ.)

### 4. Appearance Inspections

#### 4.1 Inspection level

Except for any other written agreement, the incoming inspection shall be based on MIL-STD-105E.

Acceptable Quality Level (AQL), single sampling, normal inspection, Level II.

Major: 0.65; Minor: 1.0

**4.2 Inspection area & conditions**

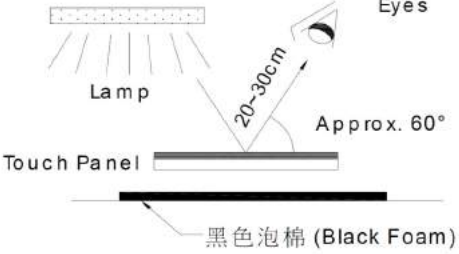
Item	Conditions
Inspection area	Inspection Area: View Area(VA). Only apply to View Area(VA), any defects found outside VA shall be ignored unless they affect electrical performance. Contaminations can be cleaned by soft cloth with ethyl alcohol shall be accepted.
Inspection Conditions	1. Inspector with a normal vision: 1.0 or above. 2. Distance between touch panel and eyes: 20-30cm, angle: approx.60° 3. Normal indoor condition: temp 25±2°C; RH:65±5% 4. Illumination conditions: fluorescent lamp 30W; 1200±200 Lux 5. Viewing time: 15±3secs.  <p>The diagram illustrates the inspection setup. A fluorescent lamp is positioned above a touch panel. An inspector's eyes are positioned at a distance of 20-30 cm from the touch panel, viewing it at an angle of approximately 60 degrees. A piece of black foam is placed behind the touch panel to prevent reflection from the back.</p>

**4.3 Inspection Criteria (within VA)**

4.3.1 Line defects (fiber or scratch)

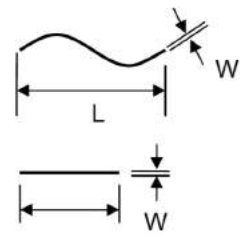
Width (W) (mm)	Length (L) (mm)	Judgement	Remark
$W \leq 0.05$	N/A	PASS	 <p>The diagram shows two types of line defects. The top one is a wavy line with a width 'W' and length 'L'. The bottom one is a straight line with a width 'W' and length 'L'.</p>
$0.05 < W \leq 0.10$	And, $L \leq 5$	$\leq 2$ lines: PASS	
	And, $L > 5$	NG	
$W > 0.10$	N/A	NG	

4.3.2 Pin defects (black/white dots, foreign substance)

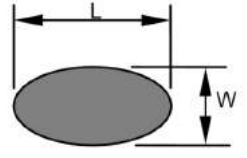
Average diameter (D) (mm)	Judgement	Remark
$D \leq 0.20$	PASS	 <p>The diagram shows an oval-shaped pin defect with a length 'L' and a width 'W'.</p> <p>平均直径 <math>D = (L+W)/2</math></p>
$0.20 < D \leq 0.3$	Qty $\leq 2$ :PASS; Otherwise: NG.	
$D > 0.30$	NG.	

4.3.3 Air bubbles after lamination

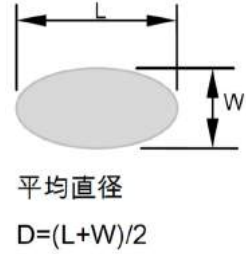
Average diameter (D) (mm)	Judgement	Remark
$D \leq 0.30$	PASS	 <p>平均直径 D=(L+W)/2</p>
$0.30 < D \leq 0.5$	Qty $\leq 2$ : PASS; Otherwise: NG.	
$D > 0.5$	NG.	

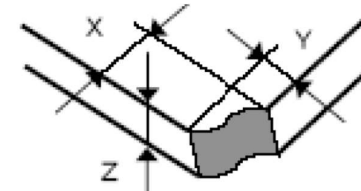
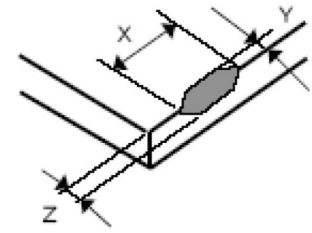
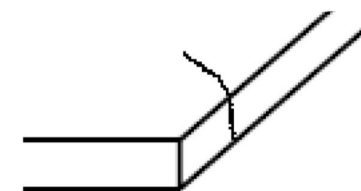

Note: If delivery in form of "ITO film + ITO film (F + F) sensor", not including cover lens, the above "4.3.3 Air bubbles after lamination" inspection standard will not be applied.

4.3.4 Chip and Crack of glass

Item	Size (mm)	Length (t=glass thickness) (mm)		Acceptable Qty
		X	Y	
Broken corner		X	$\leq 3\text{mm}$	Qty $\leq 1$
		Y	$\leq 3\text{mm}$	
		Z	$\leq t$	
Other than corner		X	$\leq 6\text{mm}$	Qty $\leq 2$
		Y	$\leq 2\text{mm}$	
		Z	$< t$	
Progressive crack or chip		NG		

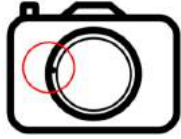

4.3.5 Icon film inspection

Item	Descriptions	Diagram/Remarks
Color	No big color different between standard sample, color different <3(computer color matching)	Computer color matching or by human eyes.
Characters & icons printing	Broken line, linkage, vein, burr, peel off are not allowed.	Broken line 
		Linkage 
		Vein 
		Burr 
Background color	Even, well cover, no light leakage on top of LCD or backlight.	---
Inner layer	Refer to Sec.4.3.1 & 4.3.2 standard	---

4.3.6 FPC tail inspections

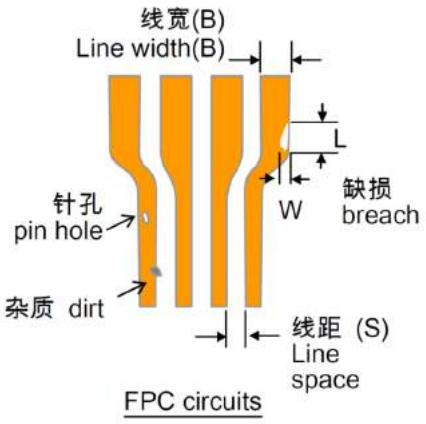
Item	Descriptions	Remarks
FPC circuits	No open or short circuits accepted. Breach or pin hole: width(W) ≤ 1/3 line width(B). length(L) ≤ 1/2 line width(B). More than 2 defects are not allowed and the 2 defects cannot be on the same circuit.	 <p>Line width(B) Line space (S) pin hole dirt breach W L FPC circuits</p>
Foreign materials	In the inner layer of FPC or on the surface of gold finger, bubble or dirt should be: 1. diameter of defect ≤ 0.2mm, and 2. quantity of defects ≤ 2, and 3. not on the same circuit. In between the circuits, bubble or dirt should be: 1. Across less than 1/3 line space(S). 2. Length of defect ≤ 1/2 line space(S).	
Gold finger & heat seal bonding pads	Oxidation or peel off of gold (or solder) plating are not allowed.	
Stiffener	Stiffener detach and peel off are not allowed.	
Cosmetic checking	Serious folding, crack, burr, scratch or press-mark are not allowed. Slightly dirt on the surface of the FPC is accepted as long as it does not affect the appearance of the product after TP assembly.	

### 5. Reliability Test

The reliability tests are conducted with following conditions, then inspect the electrical properties of the samples, the results should fulfill the specifications listed below.

#### Specifications after tests

Item	Value before testing	Specifications after tests
Insulation resistance (@DC 25V)	$\geq 20M\Omega$	$\geq 20M\Omega$
Surface resistance ( $\Omega / \square$ )	$R_0$	$R_0 \pm 30\%$
Total light transmittance	$T_0$	$T_0 \pm 10\%$
Dimensions		Within specified tolerances
Tempered glass cover	1. No crack or damage 2. No de-lamination 3. No printing peel off 4. The color may slightly change after environmental tests.	
ITO glass		
ITO film		

#### 5.1 Environmental tests

Item	Conditions	Remarks
High temperature storage test	70°C x 120hrs ;	1. Conducted in non-operation and no electric supplying conditions; 2. Inspections under standard room conditions: 25°C±2°C · 60%±5%RH; 3. Each test sample should be tested for only one test item; 4. Place the sample under room temp for 4hrs before electrical inspection.
Low temperature storage test	-20°C x 120hrs ;	
High temperature & high humidity test	60°C + RH90% x 120hrs (no dews allowed)	
Thermal shock test	(1)-20°C (30mins)→raise temp(10mins)→70°C (30mins)→lower temp(10mins) total 50cycles; (2) Place the sample under room temp for 24hrs(no dews allowed).	
Thermal cycle test	(1)-20°C (2hrs)→raise temp(1hr)→70°C (2hrs)→lower temp(1hr) total 10cycles; then (2) Place the sample under room temp for 24hrs(no dews allowed).	

### 5.2 Durability Test

Conduct the durability tests with following conditions, inspect the samples and the results should fulfill the “Specifications after tests” in this chapter.

All electrical inspections should be conducted under standard room conditions: 25°C ±2 °C , 60%±5%RH, otherwise specified.

Item	Contents
Hitting Durability (Tempered glass cover)	1. Use Polyacetal (POM) pen(Ø5.0mm); 10times/sec; 2. Within cover glass Active Area; hitting 10,000,000times; 3. Load: 250gf(~2.5N); Inspect the properties and should meet the “Specifications After Tests” in section 5.
Sliding Durability (Tempered glass cover)	1. Use Polyacetal (POM) pen(Ø5.0mm); 2. Within cover lens Active Area in diagonal direction; sliding 1,000,000times(back & forth=2 times); 60mm/sec. 3. Load: 250gf(~2.5N); Inspect the properties and should meet the “Specifications After Tests” in section 5.

### 5.3 FPC reliability tests

Item	Contents
FPC Bending durability	<div style="display: flex; justify-content: space-between;"> <div style="width: 60%;"> <ol style="list-style-type: none"> <li>Attach a load 100gf to the end of FPC; then;</li> <li>Bend the FPC with 180o x 5 times as shown.</li> <li>No detachment or no bad contact of FPC, inspect and meet specs of electrical properties (sec.3.2: loop resistance, insulation resistance, linearity).</li> </ol> </div> <div style="width: 35%; text-align: center;"> </div> </div>
FPC Heat Seal Peeling Testing	<ol style="list-style-type: none"> <li>Attach a load 500gf to the end of FPC; then</li> <li>Bend the FPC in 90o to ITO FILM direction as shown, keep for 5mins.</li> <li>No detachment or no bad contact of FPC, inspect and meet specs of electrical properties(sec.3.2: loop resistance, insulation resistance, linearity)</li> </ol> <div style="text-align: center;"> </div>

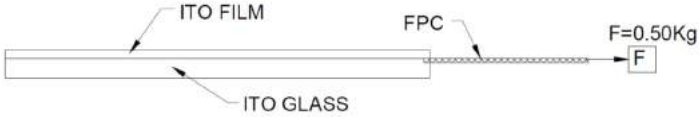
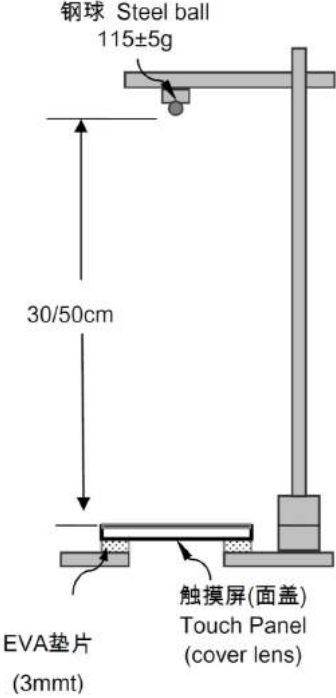
	<p>1. Attach a load 500gf to the end of FPC; then                  2. Pull the FPC in 180o direction as shown, keep for 10mins.                  3. No detachment or no bad contact of FPC, inspect and meet specs of electrical properties (sec.3.2: loop resistance, insulation resistance, linearity).</p> 
<p>Impact resistance test</p>	<p>Set up and the conditions as shown:                  1. Steel ball: 115±5g                  2. Height:                  30cm(cover glass: 0.7mmt)                  50cm(cover glass: 1.1mmt)                  3. Let the steel ball free fall to the center of the touch panel(cover glass).                  4. No broken or no scratch of TP, inspect and meet specs of electrical properties (sec.3.2: loop resistance, insulation resistance, linearity)</p> 

**6. Precautions**

This touch panel product is intended for the used in generic electronics device, such as mobile communication devices, audio visual products, GPS and portable navigation devices (PND), home appliance, office automation equipment, electronic games and toys, industrial control panel, kiosk and etc. Customer is responsible for determining whether this product is fit for his / her particular purpose and suitable for its method of production. The touch panel is not recommended to be used for special equipment requiring extremely high-reliability, which may cause body injury due to malfunction or misuse, such as space sciences, nuclear power control equipment or medical equipment for life support, Customer is responsible for determining whether the product is suitable for the purpose. Customer must also conduct careful and safety measures and testes in advance. Displaytech and its factory will not be liable for any action against it in any way related to the product or software for any loss, personal injury, death or damage whether non-specified direct, indirect, special, incidental or consequential regardless of the legal theory asserted.

### **6.1 Inspection Information**

Inspection report will be provided with each shipment, including inspections of:-

1. Dimensions
2. Resistance between terminals
3. Linearity
4. Appearance inspections
5. Operation pressure test

### **6.2 Maintenance and Precaution**

1. Do not use unsuitable stylus pen or sharp object to contact on the surface of the touch panel.
2. Do not stack the touch panel when storing as it may cause the appearance of Newton rings. Use cushion packaging material for storage.
3. Do not lift the touch panel by the FPC as it may result in bad contact or damage of the FPC.
4. Use clean and anti-static glove when handling the touch panel.
5. Use soft, lint-free cloth with mild detergent or alcohol to clean the product, avoid using gritty cloths. If the surface is dirtied by irritating substances, remove it immediately under safety condition.
6. Always handle the product with care. Be careful when touching its sharp edges and corners.
7. Please ensure enough cushion material is used to protect the fragile touch panel from external force or pressure during transportation.
8. Protect the touch panel from direct sun shine or excessive heat. Store in sealed condition under recommended temperature and humidity.
9. Operate and store away from organic solvent or acid gas.
10. Avoid the touch panel to be used under dewy condition. Usage under dew condensation may result in malfunction or accuracy of the touch panel.

### **6.3 Product warranty**

This product is warranted for one year from the date of delivery (including delivery to assigned forwarder, agent or company). However, defects on appearance are only warranted for exchanged within one month from the date of delivery.

Displaytech and its factory shall make no warranty after deliver to the customer or its sales agency or transportation agency, If the product is not used in safety and proper manners:-

1. Damages or scratches caused by improper storage or manipulation during transportation
2. Damages or losses caused by frustration or force majeure events
3. Malfunction or damages of the product as a result of static electricity
4. Defects or damages due to improper assembly or rework
5. Subsequent manufacturing, or integration processes, disassemble or repair by customer
6. Damages of terminals or appearance defects after the product has been used
7. Damages or defects through misuse, accident, negligence, subsequent manufacturing or assemblies
8. Dirt or contaminate that can be removed or cleaned by soft, lint-free cloth with ethyl alcohol will be considered as acceptable goods

Warranty is only limited to our products, Displaytech and its factory make no additional warranty, and are not responsible for any other direct or indirect loss caused by our product failure.

All non-conformance or defective items must be reported in writing. If the products are determined by our engineers to be out of specification and within warranty period, replacements will be arranged after receipt of defective items.

Due to material modifications or workmanship enhancements, same item with different materials for replacement may be happened.

## **7. Drawings, Toolings, Testing Fixtures and Information**

Tooling and fixtures will be made according to customer approved drawings. After proceed to tooling and fixtures, addition tooling and fixtures charges will be required, if major changes of design is needed, including changes of dimensions, circuit layout, FPC, Icon and etc.

In consideration of the quality of tooling and fixtures, Displaytech has its own discretion on the disposal of the tooling and fixtures if mass production is not placed one year after the last date of purchase from the customer. Customer may be required to pay the cost for new tools if production is needed.

We shall make no prior notice on the changes on the ITO film, ITO glass, FPC material, circuits design due to material modification or workmanship enhancement, under the circumstances that the function and major specifications of the product will not be affected.

## X-ON Electronics

Largest Supplier of Electrical and Electronic Components

*Click to view similar products for [TFT Displays & Accessories](#) category:*

*Click to view products by [Displaytech](#) manufacturer:*

Other Similar products are found below :

[F3ET2-005-150](#) [HDA430T-3G1H](#) [NL8048AC19-14F](#) [NL6448BC20-21D](#) [NB7W-KBA04](#) [NB-ATT01](#) [NB5Q-ATT01](#) [NB5Q-KBA04](#) [NB-CN001](#) [OAI-80038AA-2008-A](#) [315-U004B15300](#) [UMSH-8596MD-34T \(REV D\)](#) [TX14D23VM5BAA](#) [TCG121WXLRXVNNANX35](#) [EIC-LCD-1080P](#) [T-55619GD065J-LW-ABN](#) [TCG104SVLPEANN-AN30](#) [NL6448BC33-70](#) [NL6448BC20-30D](#) [NL10276BC16-06](#) [NL192108AC10-01D](#) [NL12880BC20-05BD](#) [NL8060BC26-35BA](#) [NL8060BC31-50F](#) [TM070DDHG03-40](#) [PTPW16-070WV1S02](#) [PTPW17-070WV1S02](#) [PTPW16-084SV1S02](#) [MTD0300ECP06DF-1](#) [DEM 640480E](#) [TMH-PW-N \(A-TOUCH\)](#) [RFA6400E-AWH-DNG](#) [RFA6400E-AWH-MNN](#) [RFE430V-AZW-DNS](#) [RFF70VA2-1IW-DHS](#) [RFH1010J-AYH-MNB](#) [RFH700A8-AYH-MNN](#) [RFK101VF-1YH-LHG](#) [RFS390C-AIW-DNN](#) [RFS390C-AIW-DNS](#) [RFS52VA-1ZH-DHN](#) [SM-RVT101HVHFWCA0](#) [SM-RVT101HVHFWN00](#) [SM-RVT101HVHNWC00](#) [SM-RVT101HVHNWC00-B](#) [SM-RVT101HVHNWCA0](#) [SM-RVT101HVHNWN00](#) [SM-RVT101HVLFWCA0](#) [SM-RVT101HVLNWCA0](#) [SM-RVT3.5A320240TFWN00](#) [SM-RVT35HHTFWCA0](#)