



# 8N65

## 650V N-Channel Power MOSFET

### Features

- $R_{DS(ON)} < 1.4\Omega$  @  $V_{GS} = 10V$
- Fast switching capability
- Low gate charge
- Lead free in compliance with EU RoHS directive.
- Green molding compound

### PRODUCT SUMMARY

$V_{DS}$ (V)	$R_{DS(on)}$ ( $\Omega$ )	$I_D$ (A)
650	1.4 @ $V_{GS} = 10V$	8

Pin Definition:

1. Gate
2. Drain
3. Source

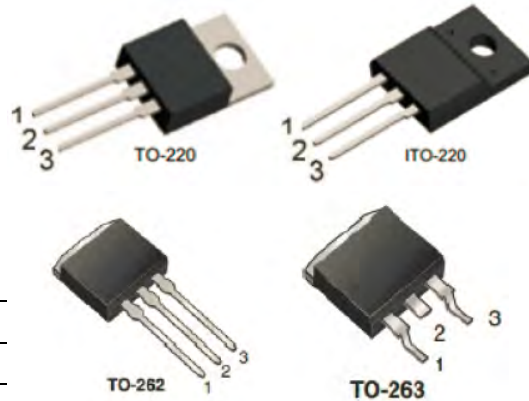

### Block Diagram

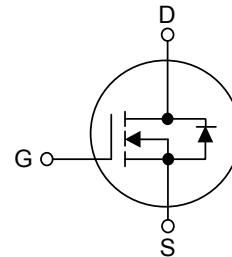

### Mechanical Data

- Case: TO-220, ITO-220, TO-262, TO-263 Package

### Ordering Information

Part No.	Package	Packing
DMT8N65-TU	TO-220	50pcs / Tube
DMF8N65-TU	ITO-220	50pcs / Tube
DMK8N65-TU	TO-262	50pcs / Tube
DMG8N65-TU	TO-263	50pcs / Tube
DMG8N65-TR	TO-263	800pcs / 13" Reel

### ABSOLUTE MAXIMUM RATINGS ( $T_C = 25^\circ C$ , unless otherwise specified)

PARAMETER	SYMBOL	RATINGS	UNIT	
Drain-Source Voltage	$V_{DSS}$	650	V	
Gate-Source Voltage	$V_{GSS}$	$\pm 30$	V	
Avalanche Current (Note 2)	$I_{AR}$	8	A	
Continuous Drain Current	$I_D$	8	A	
Pulsed Drain Current (Note 2)	$I_{DM}$	32	A	
Avalanche Energy	Single Pulsed (Note 3)	$E_{AS}$	230	mJ
Peak Diode Recovery dv/dt (Note 4)	dv/dt	4.5	ns	
Power Dissipation	TO-220/TO-262/TO-263	$P_D$	142	W
	ITO-220		48	W
Junction Temperature	$T_J$	+150	$^\circ C$	
Operating Temperature	$T_{OPR}$	-55 ~ +150	$^\circ C$	
Storage Temperature	$T_{STG}$	-55 ~ +150	$^\circ C$	

Notes: 1. Absolute maximum ratings are those values beyond which the device could be permanently damaged.

Absolute maximum ratings are stress ratings only and functional device operation is not implied.

2. Repetitive Rating : Pulse width limited by  $T_J$

3.  $L = 7.1mH$ ,  $I_{AS} = 8A$ ,  $V_{DD} = 50V$ ,  $R_G = 25\Omega$ , Starting  $T_J = 25^\circ C$

4.  $I_{SD} \leq 7.5A$ ,  $di/dt \leq 200A/\mu s$ ,  $V_{DD} \leq BV_{DSS}$ , Starting  $T_J = 25^\circ C$



# 8N65

## 650V N-Channel Power MOSFET

### THERMAL DATA

PARAMETER		SYMBOL	RATING	UNIT
Junction to Ambient	TO-220/ITO-220 TO-262/TO-263	$\theta_{JA}$	62.5	$^{\circ}\text{C}/\text{W}$
Junction to Case	TO-220/TO-262/TO-263	$\theta_{JC}$	0.85	$^{\circ}\text{C}/\text{W}$
	ITO-220		2.6	

### ELECTRICAL CHARACTERISTICS ( $T_C=25^{\circ}\text{C}$ , unless otherwise specified)

PARAMETER		SYMBOL	TEST CONDITIONS	MIN	TYP	MAX	UNIT
<b>OFF CHARACTERISTICS</b>							
Drain-Source Breakdown Voltage		$BV_{DSS}$	$V_{GS}=0\text{V}, I_D=250\mu\text{A}$	650			V
Drain-Source Leakage Current		$I_{DSS}$	$V_{DS}=650\text{V}, V_{GS}=0\text{V}$			10	$\mu\text{A}$
Gate- Source Leakage Current	Forward	$I_{GSS}$	$V_{GS}=30\text{V}, V_{DS}=0\text{V}$			100	nA
	Reverse		$V_{GS}=-30\text{V}, V_{DS}=0\text{V}$			-100	nA
Breakdown Voltage Temperature Coefficient		$\Delta BV_{DSS}/\Delta T_J$	$I_D=250\mu\text{A}$ , Referenced to $25^{\circ}\text{C}$		0.7		$\text{V}/^{\circ}\text{C}$
<b>ON CHARACTERISTICS</b>							
Gate Threshold Voltage		$V_{GS(TH)}$	$V_{DS}=V_{GS}, I_D=250\mu\text{A}$	2.0		4.0	V
Static Drain-Source On-State Resistance		$R_{DS(ON)}$	$V_{GS} = 10\text{V}, I_D = 4\text{A}$		1.2	1.4	$\Omega$
<b>DYNAMIC CHARACTERISTICS</b>							
Input Capacitance		$C_{ISS}$	$V_{DS}=25\text{V}, V_{GS}=0\text{V}, f=1.0\text{ MHz}$		1145	1255	pF
Output Capacitance		$C_{OSS}$			118	135	pF
Reverse Transfer Capacitance		$C_{RSS}$			19	25	pF
<b>SWITCHING CHARACTERISTICS</b>							
Turn-On Delay Time		$t_{D(ON)}$	$V_{DD} = 520\text{V}, I_D = 8\text{A},$ $R_G = 25\Omega$ (Note 1, 2)		84	100	ns
Turn-On Rise Time		$t_R$			100	130	ns
Turn-Off Delay Time		$t_{D(OFF)}$			275	320	ns
Turn-Off Fall Time		$t_F$			64.5	140	ns
Total Gate Charge		$Q_G$	$V_{DS}=480\text{V}, I_D=8\text{A},$ $V_{GS}=10\text{V}$ (Note 1, 2)		115	130	nC
Gate-Source Charge		$Q_{GS}$			12		nC
Gate-Drain Charge		$Q_{GD}$			40		nC
<b>DRAIN-SOURCE DIODE CHARACTERISTICS AND MAXIMUM RATINGS</b>							
Drain-Source Diode Forward Voltage		$V_{SD}$	$V_{GS} = 0\text{V}, I_S = 8\text{A}$			1.4	V
Maximum Continuous Drain-Source Diode Forward Current		$I_S$				8	A
Maximum Pulsed Drain-Source Diode Forward Current		$I_{SM}$				32	A
Reverse Recovery Time		$t_{rr}$	$V_{GS}=0\text{V}, I_S=8\text{A},$		365		ns
Reverse Recovery Charge		$Q_{RR}$	$di_F/dt = 100\text{ A}/\mu\text{s}$ (Note 1)		3.4		$\mu\text{C}$

- Notes: 1. Pulse Test: Pulse width  $\leq 300\mu\text{s}$ , Duty cycle  $\leq 2\%$ .  
 2. Essentially independent of operating temperature.



### TEST CIRCUITS AND WAVEFORMS

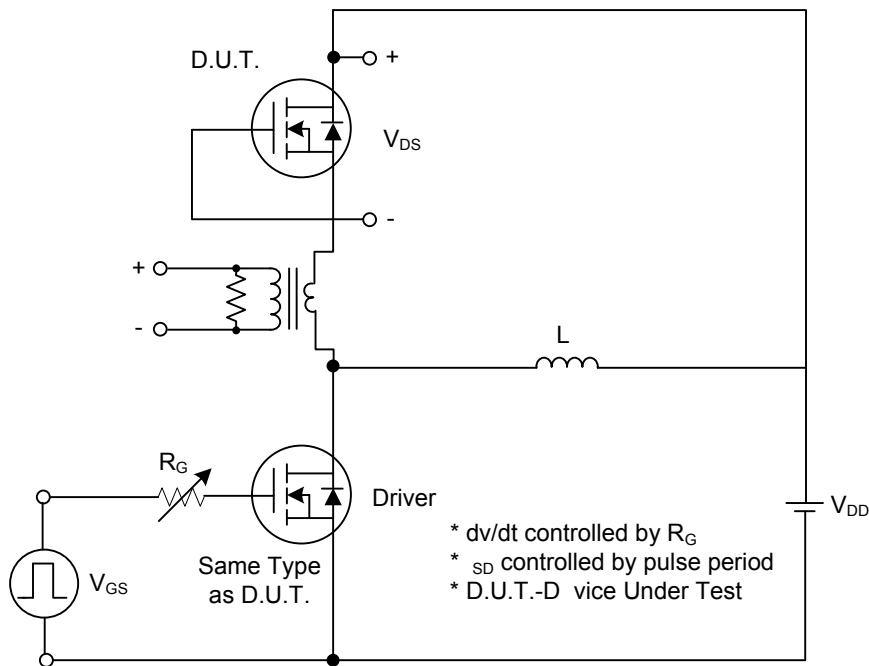

**Peak Diode Recovery  $dv/dt$  Test Circuit**

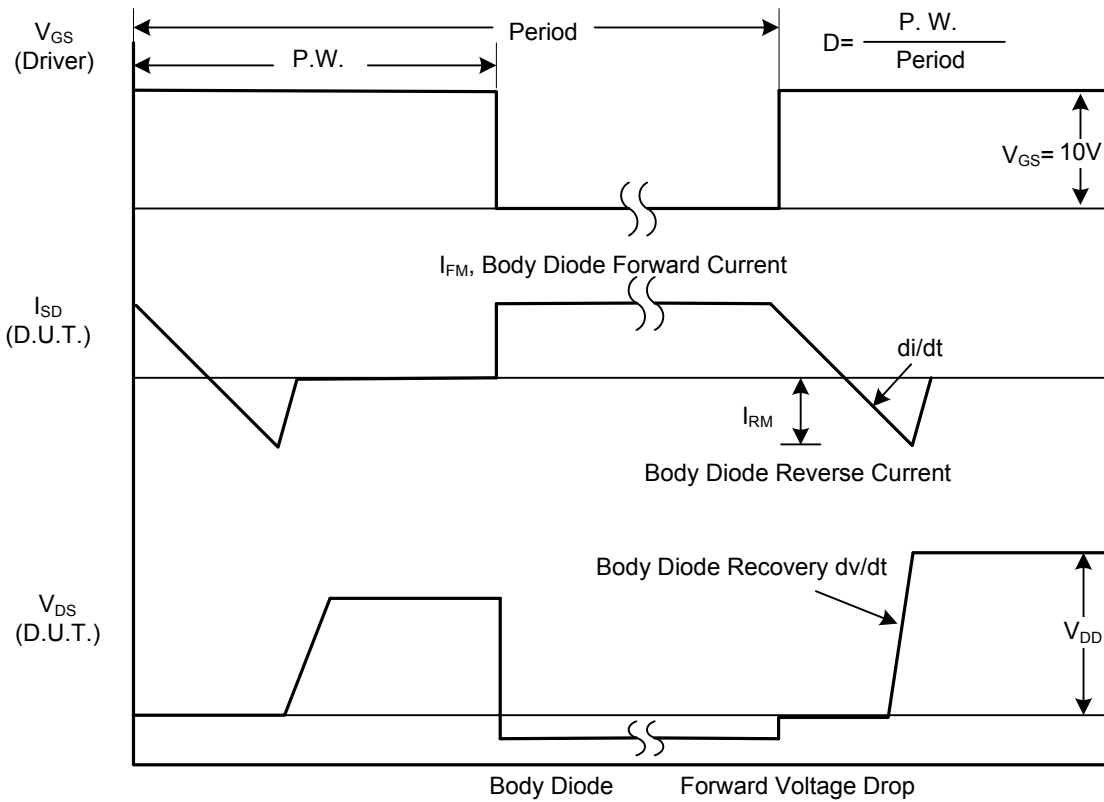

**Peak Diode Recovery  $dv/dt$  Waveforms**



### TEST CIRCUITS AND WAVEFORMS(Cont.)

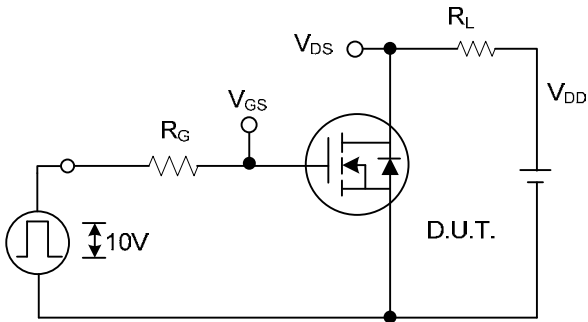

Switching Test Circuit

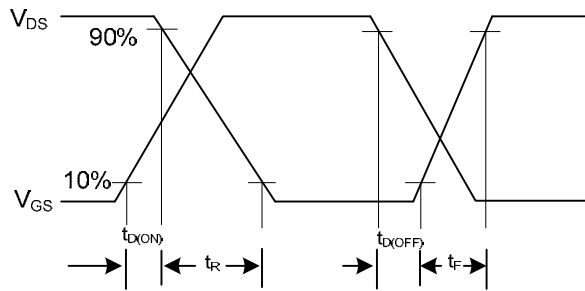

Switching Waveforms

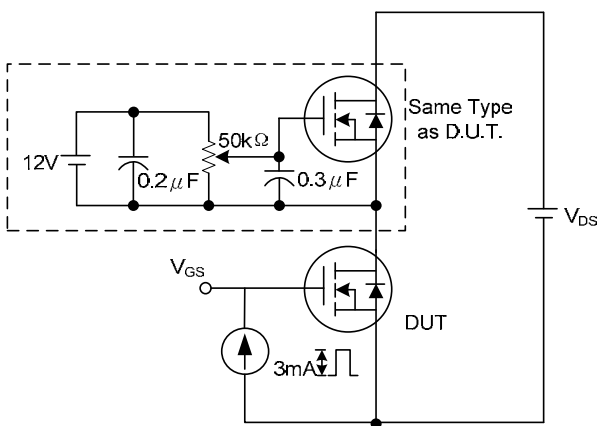

Gate Charge Test Circuit

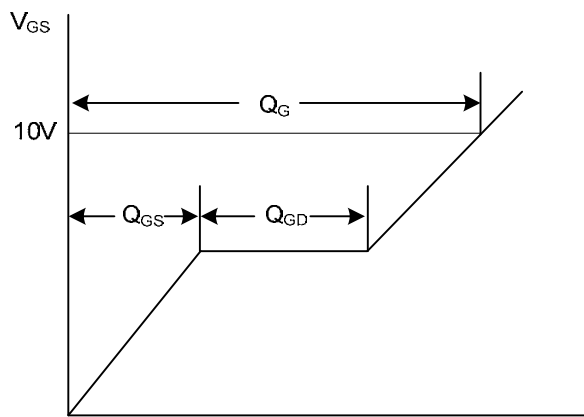

Charge  
Gate Charge Waveform

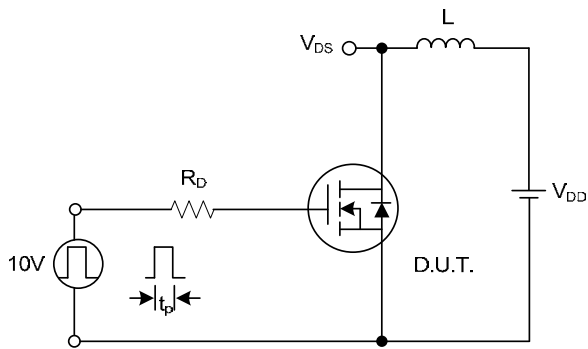

Unclamped Inductive Switching Test Circuit

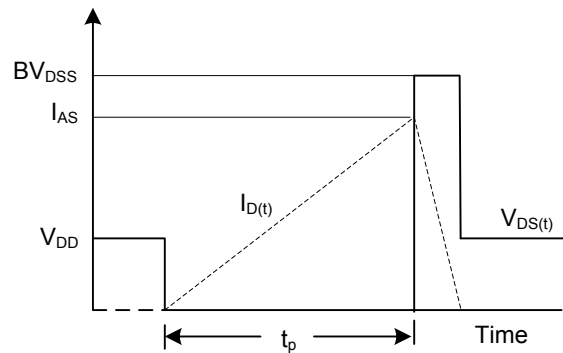

Unclamped Inductive Switching Waveforms



### TYPICAL CHARACTERISTICS

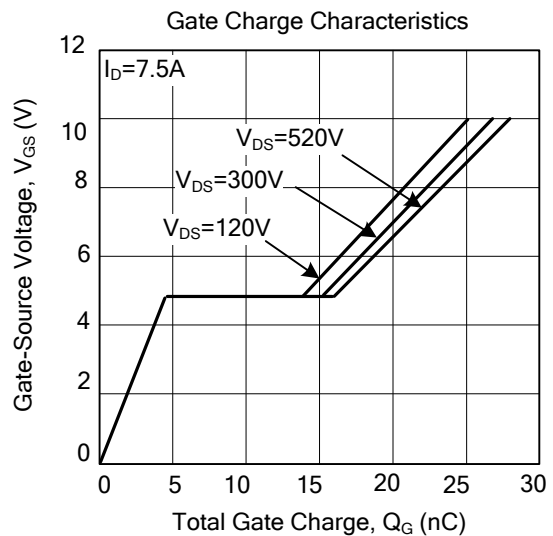
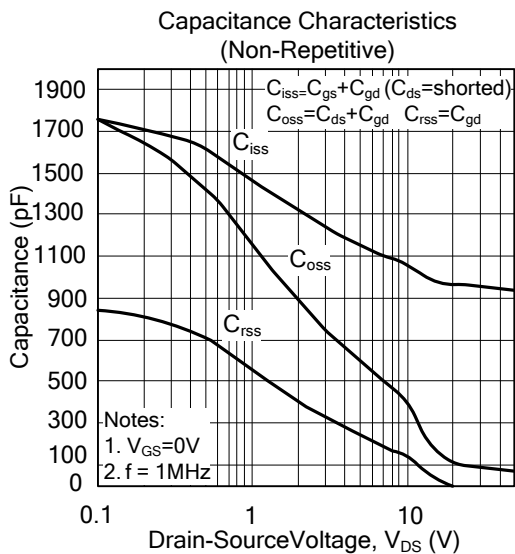
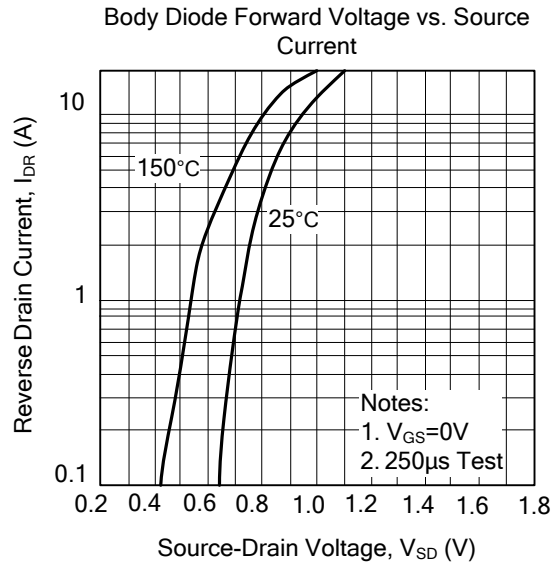
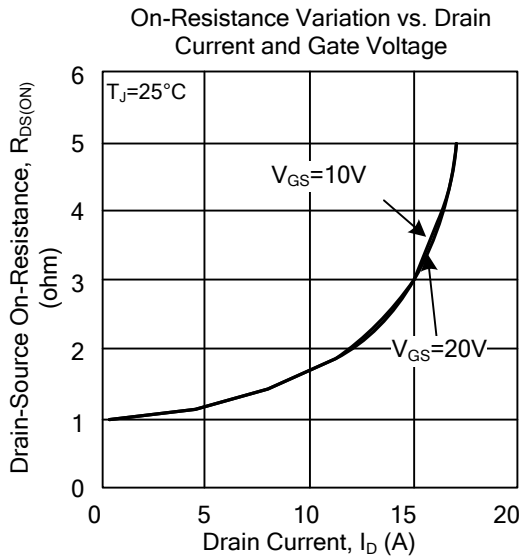
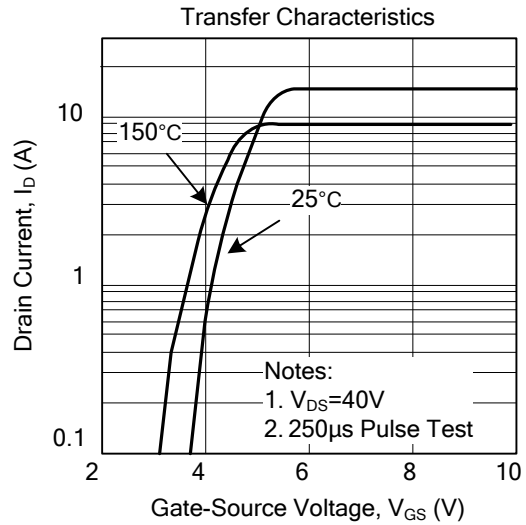
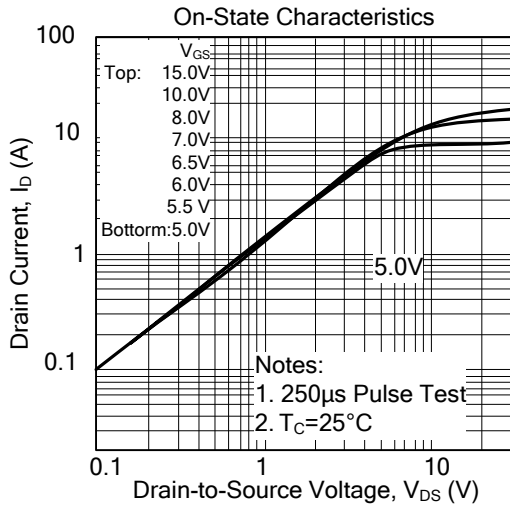



### TYPICAL CHARACTERISTICS

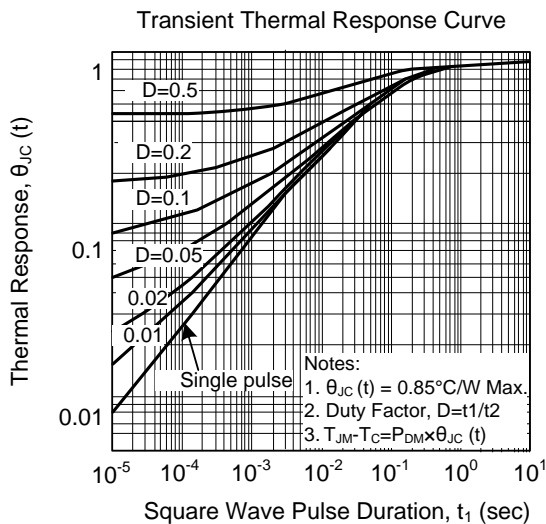
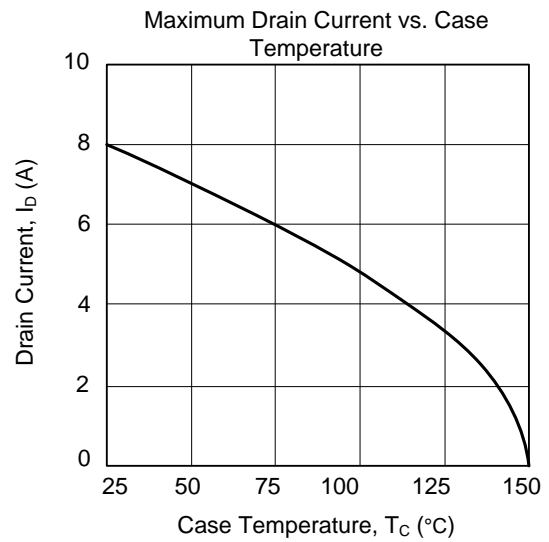
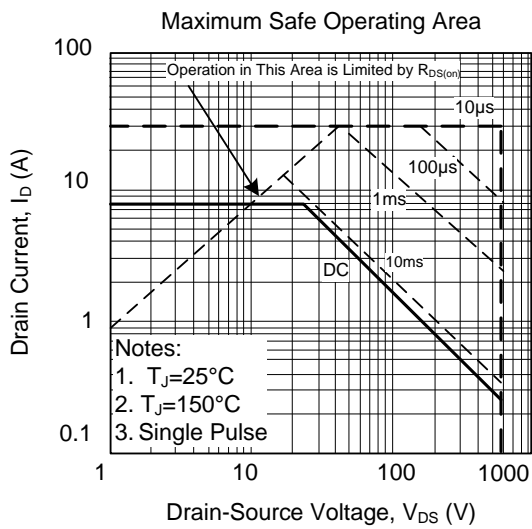
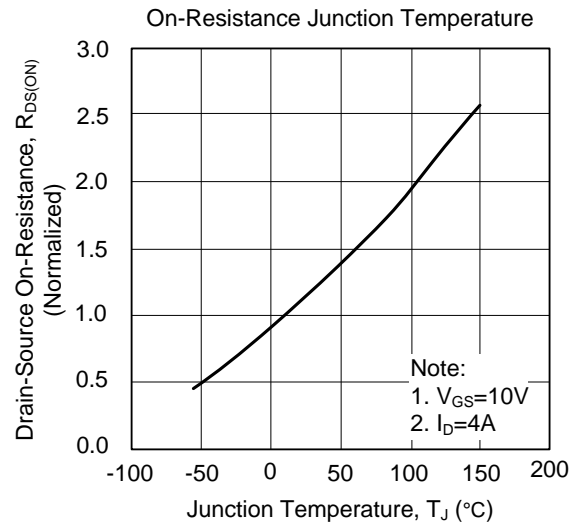
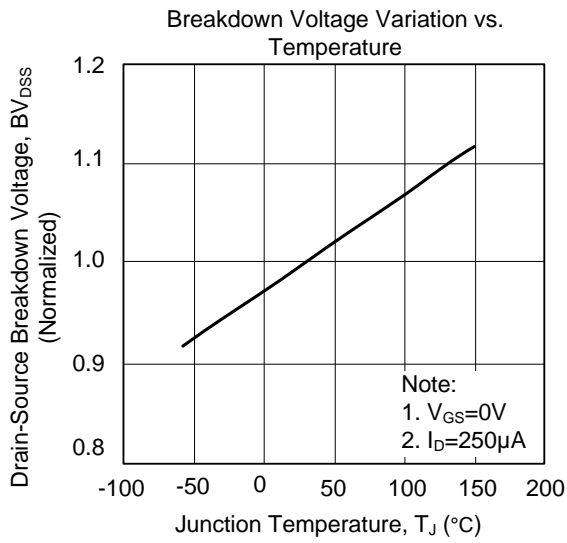



### TO-220 Mechanical Drawing

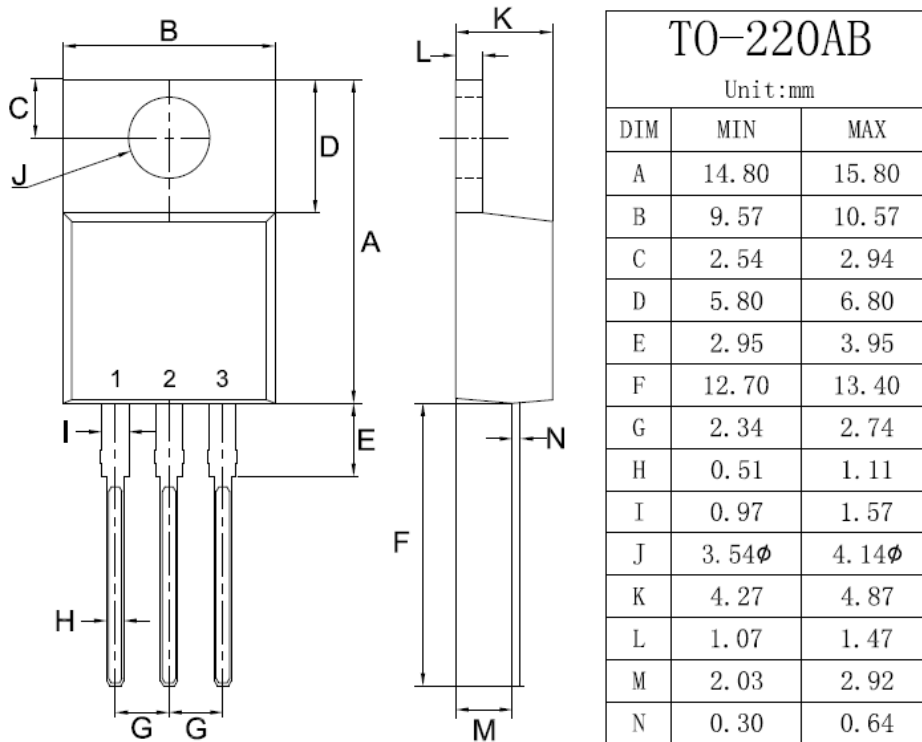

### ITO-220 Mechanical Drawing

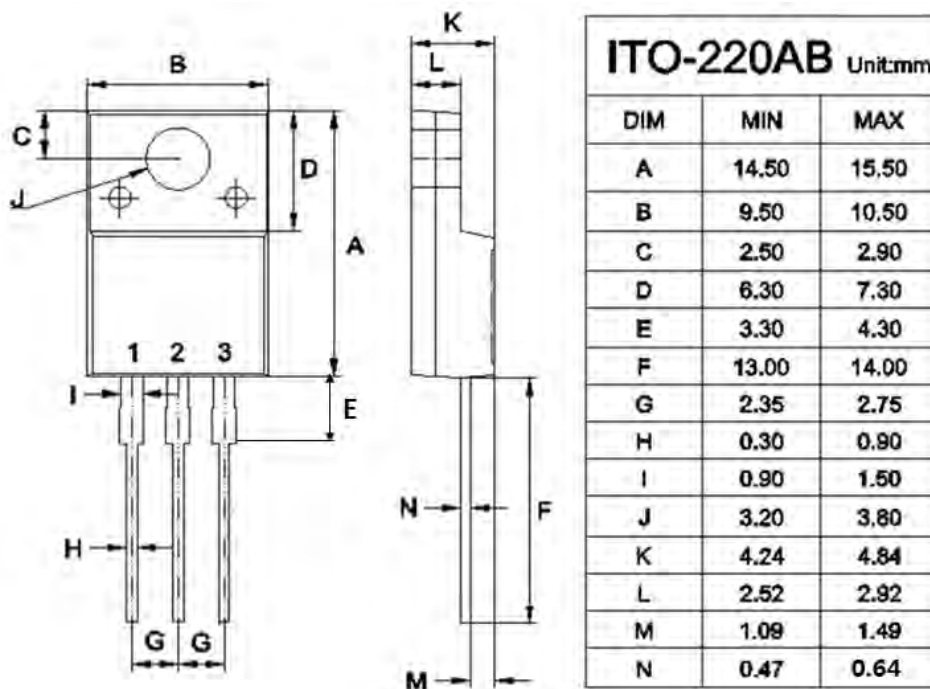



**TO-262 Mechanical Drawing**

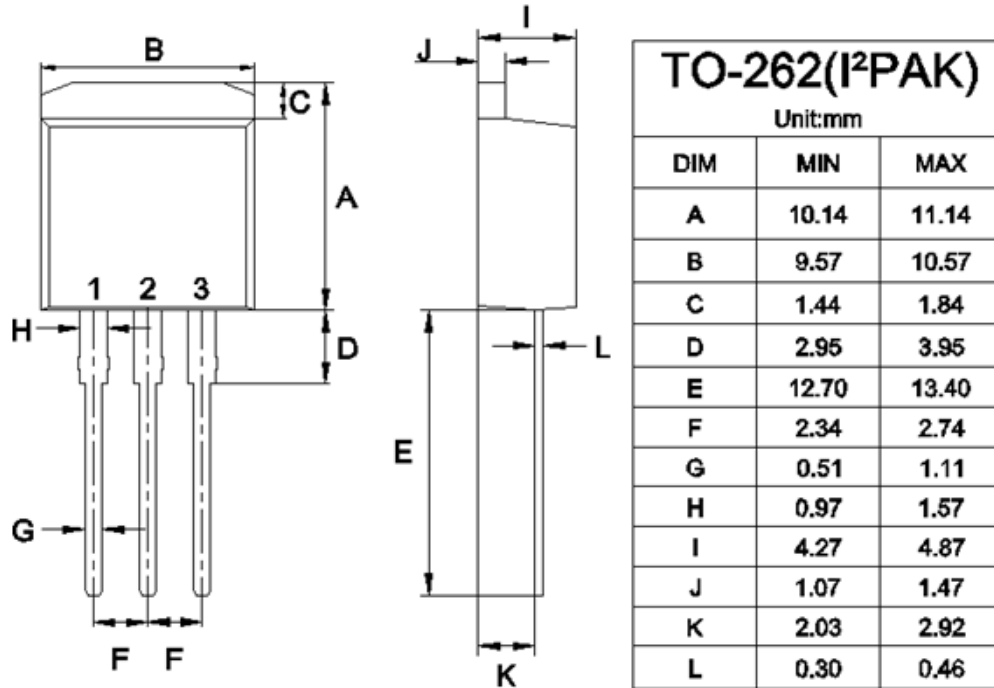

**TO-263 Mechanical Drawing**

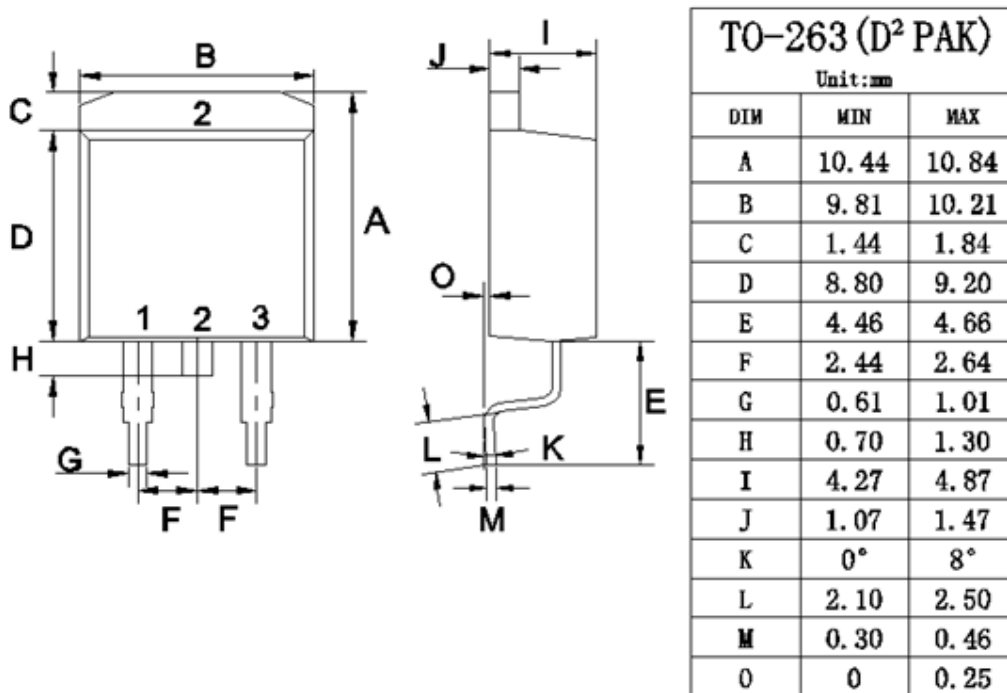



## X-ON Electronics

Largest Supplier of Electrical and Electronic Components

*Click to view similar products for [MOSFET](#) category:*

*Click to view products by [DIYI](#) manufacturer:*

Other Similar products are found below :

[IRFD120](#) [JANTX2N5237](#) [BUK455-60A/B](#) [MIC4420CM-TR](#) [VN1206L](#) [NDP4060](#) [SI4482DY](#) [IPS70R2K0CEAKMA1](#) [SQD23N06-31L-GE3](#)  
[TK16J60W,S1VQ\(O](#) [2SK2614\(TE16L1,Q\)](#) [DMN1017UCP3-7](#) [DMN1053UCP4-7](#) [SQJ469EP-T1-GE3](#) [NTE2384](#) [DMC2700UDMQ-7](#)  
[DMN2080UCB4-7](#) [DMN61D9UWQ-13](#) [US6M2GTR](#) [DMN31D5UDJ-7](#) [DMP22D4UFO-7B](#) [DMN1006UCA6-7](#) [DMN16M9UCA6-7](#)  
[STF5N65M6](#) [IRF40H233XTMA1](#) [STU5N65M6](#) [DMN6022SSD-13](#) [DMN13M9UCA6-7](#) [DMTH10H4M6SPS-13](#) [DMN2990UFB-7B](#)  
[IPB80P04P405ATMA2](#) [2N7002W-G](#) [MCAC30N06Y-TP](#) [MCQ7328-TP](#) [BXP7N65D](#) [BXP4N65F](#) [AOL1454G](#) [WMJ80N60C4](#) [BXP2N20L](#)  
[BXP2N65D](#) [BXT1150N10J](#) [BXT1700P06M](#) [TSM60NB380CP](#) [ROG](#) [RQ7L055BGTCR](#) [DMNH15H110SK3-13](#) [SLF10N65ABV2](#)  
[BSO203SP](#) [BSO211P](#) [IPA60R230P6](#) [IPA60R460CE](#)