



MURB810~MURB860

ULTRAFAST RECOVERY RECTIFIERS

VOLTAGE	100 to 600 Volts
CURRENT	8 Amperes

FEATURES

- Plastic package has Underwriters Laboratory Flammability Classification 94V-0. Flame Retardant Epoxy Molding Compound.
- Low power loss, high efficiency.
- Low forward voltage, high current capability.
- High surge capability
- Ultra fast recovery time, high voltage.
- Lead free in comply with EU RoHS.

MECHANICAL DATA

- Case: TO-263AC molded plastic
- Terminals: solder plated, solderable per MIL-STD-750, Method 2026
- Polarity: As marked.
- Mounting Position: Any

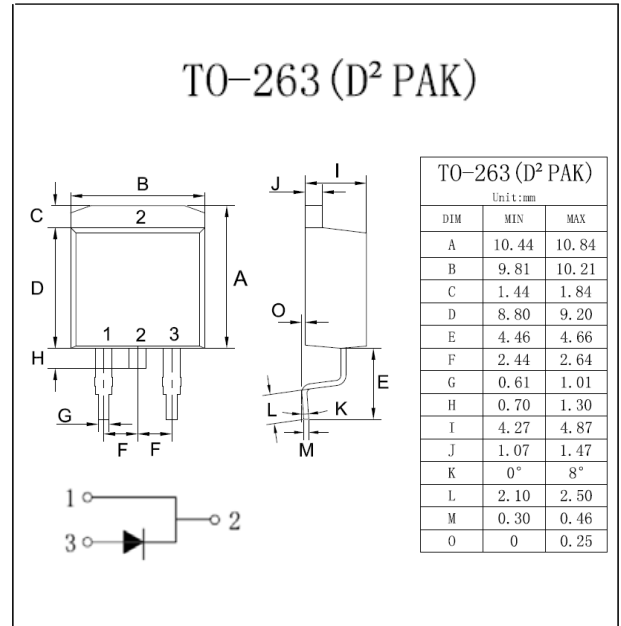

MAXIMUM RATINGS AND ELECTRICAL CHARACTERISTICS

Ratings at 25°C ambient temperature unless otherwise specified. Single phase, half wave, 60 Hz, resistive or inductive load.

For capacitive load, derate current by 20%

PARAMETER	SYMBOL	MURB 810	MURB 820	MURB 830	MURB 840	MURB 850	MURB 860	UNITS
Maximum Recurrent Peak Reverse Voltage	V_{RRM}	100	200	300	400	500	600	V
Maximum RMS Voltage	V_{RMS}	70	140	210	280	350	420	V
Maximum DC Blocking Voltage	V_{DC}	100	200	300	400	500	600	V
Maximum Average Forward Rectified Current at $T_c=100^\circ\text{C}$	$I_{F(AV)}$	8						A
Peak Forward Surge Current : 8.3ms single half sine-wave superimposed on rated load (JEDEC method)	I_{FSM}	125						A
Maximum Forward Voltage at 8A	V_F	1	1.3		1.7			V
Maximum DC Reverse Current at Rated DC Blocking Voltage $T_j=25^\circ\text{C}$ $T_j=125^\circ\text{C}$	I_R	10 500						μA
Maximum Thermal Resistance (Note 2)	$R_{\theta JC}$	5						$^\circ\text{C} / \text{W}$
Typical Junction Capacitance	C_j	80				50		pF
Maximum Reverse Recovery Time (Note 1)	t_{rr}	35						ns
Operating Junction and Storage Temperature Range	T_j, T_{STG}	-55 to +150						$^\circ\text{C}$

NOTES:

1. Reverse Recovery Test Conditions: $I_F=0.5\text{A}$, $I_R=1\text{A}$, $I_{rr}=0.25\text{A}$.
2. Thermal resistance from Junction to ambient and from junction to lead 0.375" (9.5mm) P.C.B mounte



RATING AND CHARACTERISTIC CURVES

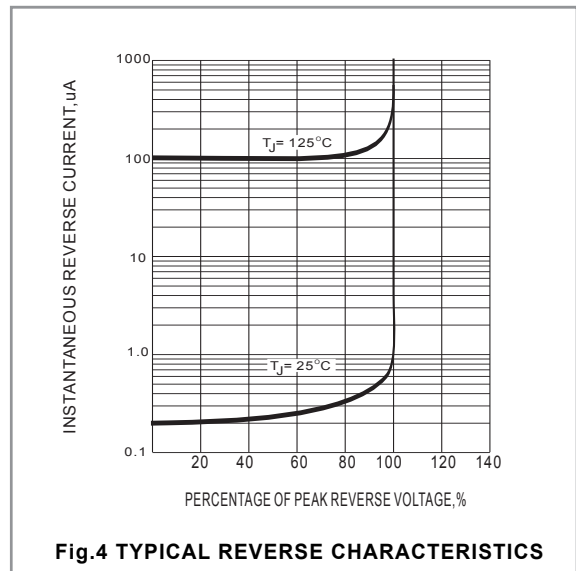
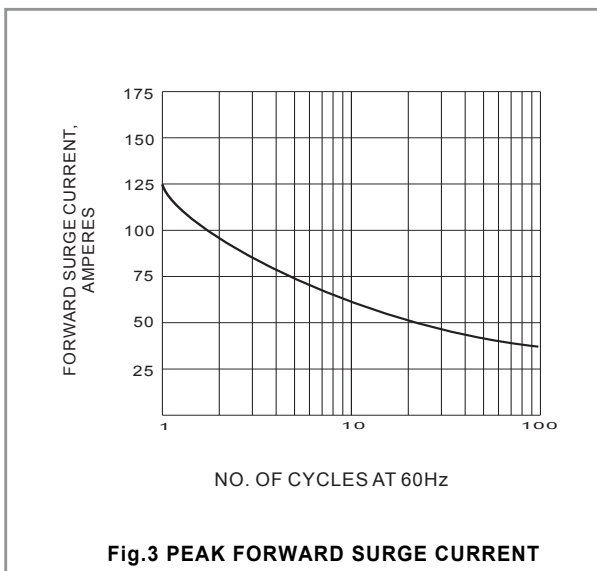
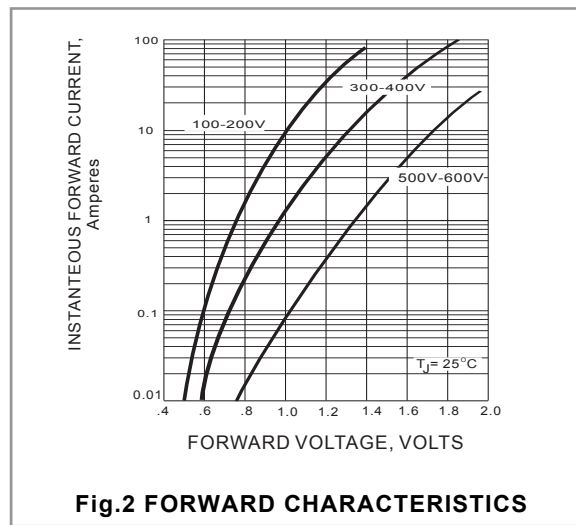
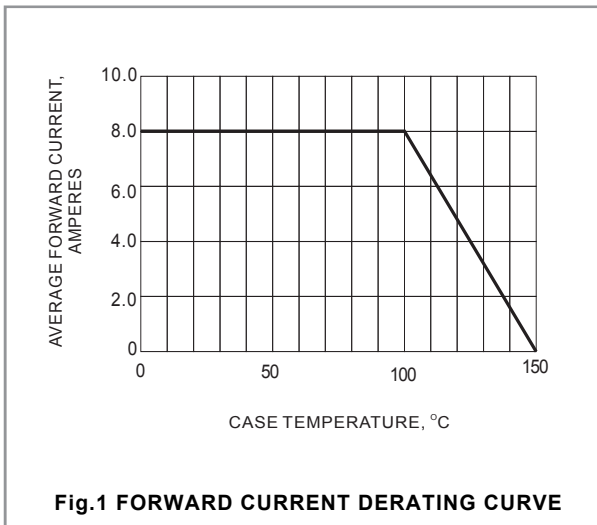

X-ON Electronics

Largest Supplier of Electrical and Electronic Components

Click to view similar products for [Rectifiers](#) category:

Click to view products by [DIYI](#) manufacturer:

Other Similar products are found below :

[70HFR40](#) [FR105 R0](#) [RL252-TP](#) [1N5397](#) [1N4005-TR](#) [1N4007-BP](#) [UFS120Je3/TR13](#) [20ETS12S](#) [RRE02VS6SGTR](#) [MS306](#) [A1N5404G-G](#)
[CRF02\(T5L,TEMQ\)](#) [ACGRB207-HF](#) [CLH07\(TE16L,Q\)](#) [CLH03\(TE16L,Q\)](#) [1N5395-TP](#) [UES1302](#) [ACGRC307-HF](#) [ACEFC304-HF](#) [DZ-](#)
[1380](#) [85HFR60](#) [40HFR60](#) [70HF120](#) [85HFR80](#) [SCF7500](#) [SM100](#) [ACGRA4001-HF](#) [SKN70/08](#) [NTE5819](#) [NTE5827](#) [NTE5828](#) [NTE5911](#)
[NTE5915](#) [NTE6104](#) [NTE6163](#) [NTE6164](#) [NTE6165](#) [NTE6364](#) [TSD3G](#) [SET130312](#) [NRVUS110VT3G](#) [UES1106](#) [UES1306](#)
[NRVUS240VT3G](#) [D5FE60-5063](#) [R4000GPS-TP](#) [D4015L56TP](#) [UES1306HR2](#) [FX20K120](#) [D20XB60-7101](#)