



# DLP-RFID2 & DLP-RFID2D

## FEATURES:

- 13.56MHz Reader/Writer
- RFID/NFC Reader, NFC Peer and In-Card Emulation Modes
- NFCIP-1 (ISO/IEC 18092) and NFCIP-2 (ISO/IEC 21481)
- ISO 15693, 18000-3, 14443A/B and FeliCa
- Reads the UID of Up To 15 Tags Simultaneously
- U.fl External Antenna Connector
- On-Board Internal Antenna
- FCC/IC/RED Modular Approvals in Place
- Powered by a 3.0- to 5.0-Volt Supply
- Current Consumption Reading: 55mA (Idle: 4.4mA)
- TTL Serial Interface at 115,200 Baud
- Operating Temperatures: 0°C to 70°C
- Dimensions: (L x W x H) 1.65" x 0.735" x 0.17"



**DLP-RFID2 SMT Module**

## APPLICATIONS:

- Real-Time Security
- Personal Identification
- Pharmaceutical Tracking
- Inventory/Asset Management & Tracking
- Library/Book Management & Tracking
- Baggage Tagging
- Sports Event Timing



**DLP-RFID2D USB Dongle**

## **1.0 INTRODUCTION**

The DLP-RFID2 is a low-cost, compact module for reading from and writing to HF RFID transponder tags via an internal or external antenna. It has the ability to both read and write data in addition to reading the unique identifier (UID). All of the DLP-RFID2's electronics reside on a single, compact PCB, and all operational power is taken from one 3.0- to 5.0-volt supply. An external antenna can be connected via a standard u.fl connector or IO pin/pads.

## 2.0 DEVELOPMENT KIT

The DLP-RFID2-EDK kit is available to assist the developer in creating host software for the DLP-RFID2. The kit includes one RFID2 module, a DLP-RFID2U demonstration platform with an MSP430 microcontroller and LCD module, and a selection of small-format HF antennas as shown below:

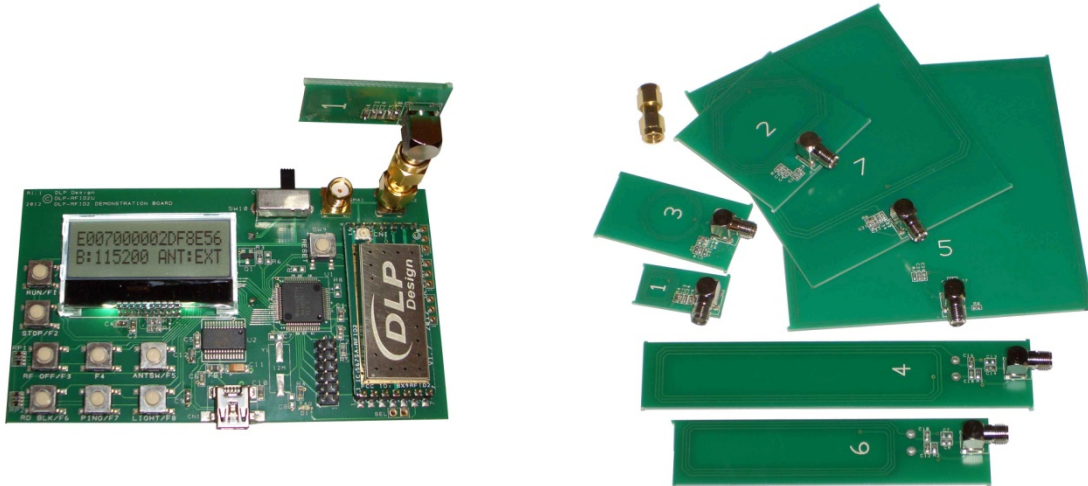

**DLP-RFID2-EDK: DLP-RFID2U, DLP-RFID2 (shown mounted to the RFID2U) and Antenna Selection**

Source code for the MSP430 microcontroller on the DLP-RFID2U is available for download upon purchase of the kit. The source code was developed for use with the free version of Code Composer Studio™ from Texas Instruments. The DLP-RFID2U is also compatible with the Texas Instruments demonstration GUI. In this mode, data from the GUI passes through the DLP-RFID2U to the DLP-RFID2 module unchanged. (An electrical schematic for the DLP-RFID2U as well as a simplified schematic of the DLP-RFID2 are provided at the end of this datasheet.)

The antenna selection is designed to provide the developer with a variety of sizes and shapes to assist in the selection of an appropriately sized antenna. (The size and shape of the antenna and RFID tags have a direct impact on the resulting read range.) The DLP-RFID2U module provides both standard SMA and reverse-polarity SMA connectors for connecting to the antennas. The antennas can be connected via either the provided SMA adapter or a user-supplied coax cable.

While the DLP-RFID2 is designed to be surface mountable to the host PCB, it is not recommended that the user surface mount it to the DLP-RFID2U unless he or she intends to use only the external antennas. The ground plane on the bottom layer of the DLP-RFID2U PCB has an adverse effect on the read range of the internal antenna in the DLP-RFID2 module. If a developer wants to use the DLP-RFID2's internal antenna while mounted to the DLP-RFID2U, then the module should be mounted using through-hole headers to raise the module up off the RFID2U PCB. The performance of the DLP-RFID2's internal antenna will decrease as the distance between the two PCB's decreases due to the proximity of the ground plane in the DLP-RFID2U.

### 3.0 MODULE PINOUT

DLP-RFID2 Module IO Pins	
1	Data Out to the Host Processor (TTL Serial: 0-3V)
2	Data In from the Host (TTL Serial: 0-3V)
3	Reset In
4	Ground
5	P1.2 General-Purpose IO
6	P1.4 LED Output – Repeatedly pulses high for 12mS if tag is present in field right at power up of the module. Mode is terminated upon receipt of first command packet.
7	VCC In: 3.0-5.0V Power
8	P2.4 General Purpose IO
9	Ground
10	P2.5 General Purpose IO
11	No connect
12	Ground
13	RF Out to the External Antenna
14	Ground

### 4.0 POWER SUPPLY SUPERVISOR

The microcontroller in the DLP-RFID2 must not be allowed to run at a power supply voltage of less than 2.3 volts. Under this condition it is possible for the flash program memory to become corrupted. Use of a power supply supervisor is recommended to force reset low should this condition occur. The two areas of concern are when running from battery power and the batteries approach end of life, and when the host power supply is turned off and the power applied to the RFID2 module slowly drifts down to a low voltage as the system power supply filter capacitors discharge.

For example, a supervisor with a trip point of 4.5V can be employed in systems that power the RFID2 at 5V. In 3V systems, a supervisor with a trip point of 2.3V can be used.

If the RFID2 module is run in this condition and the flash program memory becomes corrupted, it may be necessary to reprogram the flash program memory to restore normal operation.

### 5.0 APPLICATION DEVELOPMENT

Demonstration source code is available for download (upon purchase) that demonstrates the communications protocol for the DLP-RFID2. The source code was developed to run in an MSP430 microcontroller and be compiled using the Code Composer Studio compiler from Texas Instruments. If using a microcontroller as the host, interrupts must be used with the UART (115,200 baud, 8, N, 1) to capture data that is returned from the DLP-RFID2.

In addition to controlling the DLP-RFID2 with a simple microcontroller, a host PC can be used, and the interface from the host to the module is either a USB or RS232 port. In either case, a conversion must be made from USB or RS232 to 3V TTL serial. The DLP-RFID2D implements an easy-to-use USB interface that is powered by the USB host 5V supply. A host application and its source code (Visual C++ 2010) are available for download that demonstrates reading RFID tags from a host PC.

***The DLP-RFID2 and DLP-RFID2D are also compatible with the Texas Instruments demonstration GUI.***

## 5.1 PACKET STRUCTURE AND COMMANDS

This section explains how to configure the DLP-RFID2 for the ISO15693 protocol (13.56 MHz HF transponders). It also details the structure of selected commands:

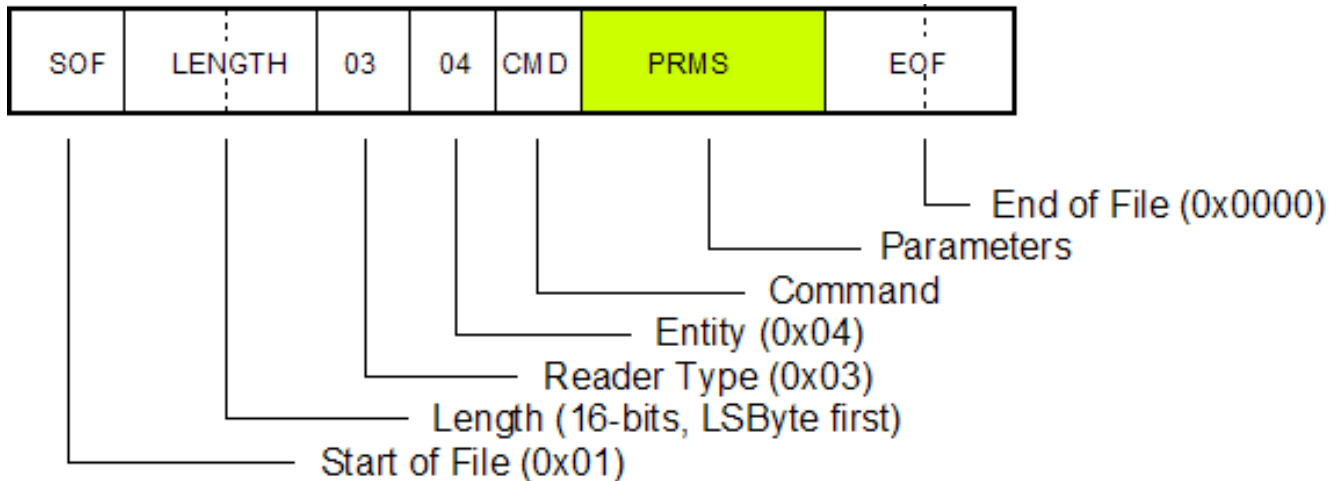

**Packet Structure**

Below are some examples of command strings for reading ISO15693 tags:

```

Ping:                                0108000304FF0000
Enable Internal Antenna:             01080003042A0000
Enable External Antenna:            01080003042B0000
Read UID from a Single ISO15693 Tag (Single-Slot Inventory):
  Set ISO15693 Mode:                 010C00030410002101000000
  AGC Toggle:                        0109000304F0000000
  AM/PM Toggle:                      0109000304F1FF0000
  Single-Slot Inventory Request:      010B000304142401000000
Read a Block from a Texas Instruments ISO15693 Tag:
  Set Read Mode to User Memory:       010C00030410002101000000
  AGC Toggle:                        0109000304F0000000
  AM/PM Toggle:                      0109000304F1FF0000
  Read Block 4:                      010B000304180020040000
Turn RF Carrier Off:                010A0003041000010000
  
```

Note that each character is sent as a binary value. For example, 0108000304FF0000 is sent to the RFID2 as 16 8-bit bytes: 0x30, 0x31, 0x30, 0x38, 0x30, etc...

There is additional code in the firmware for controlling ports P2.4 and P2.5. First set the mode to select either digital output or serial output at 9600 baud.

```

Set P2.4 for digital out: 01090003042C010000
Set P2.5 for digital out: 01090003042C020000
Set P2.4 for serial out at 9600 baud: 01090003042C040000
  
```

Set P2.5 for serial out at 9600 baud: 01090003042C050000

Then send digital hi/lo or a single byte of serial data at 9600 baud.

If P2.4 is set for digital mode then set P2.4 high: 010A0003042D01010000

If P2.5 is set for digital mode then set P2.5 high: 010A0003042D02010000

If P2.4 is set for digital mode then set P2.4 low: 010A0003042D01000000

If P2.5 is set for digital mode then set P2.5 low: 010A0003042D02000000

If P2.4 is set for serial mode then clock out 0xA2 on P2.4: 010A0003042D01A20000

If P2.5 is set for serial mode then clock out 0x56 on P2.5: 010A0003042D01560000

## 5.2 RAW WRITE

It may be possible that custom command(s) are required for a new HF RFID tag not yet fully supported by the existing ISO15693 protocols. Instead of reprogramming the MSP430 microcontroller in the DLP-RFID2 with custom firmware, the "Raw Write" command can be used to send a custom host command from the RFID2 to the new/custom RFID tag.

The raw write command code is '18'. When using this command, everything after the 18 is what is actually transmitted over the air.

Here is an example of an ISO14443B Attrib command using the raw write '18' command.

0111000304181DBC2E8C8E000805000000 - Entire example host command

01-start byte

11 -length

000304 - constant

18 -request command

1DBC2E8C8E00080500 - the data

0000 - end of packet token

With the 18 request command type, the data is essentially what is transmitted over the air minus the SOF, EOF and CRC bytes.

The return format for this example attrib is [80]. The returned data is enclosed in brackets.

For a detailed description of the various supported protocols, please refer to the EVM guide:

<http://www.mouser.com/ds/2/405/slou321-95483.pdf>

Additional information and downloads are available from the DLP Design site. The URL for this download page is printed on the anti-static bag that the DLP-RFID2 product is shipped in.

## 6.0 MECHANICAL DIMENSIONS

Inches (mm)

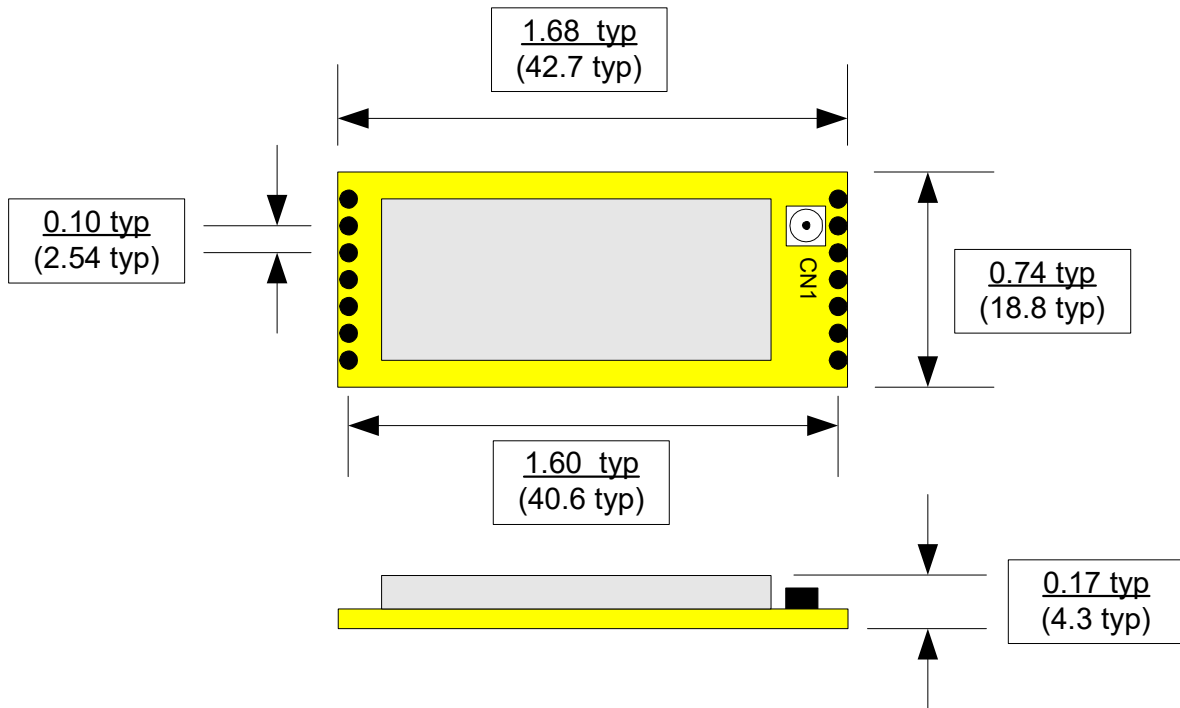

## 7.0 REGULATORY AGENCY CONSIDERATIONS

### 7.1 AGENCY IDENTIFICATION NUMBERS

Compliance with the appropriate regulatory agencies is essential in the deployment of all transceiver devices. DLP Design has obtained modular approval for this RF product such that an OEM need only meet a few basic requirements in order to utilize their end product under this approval. Corresponding agency identification numbers are listed below:

<u>PART NUMBER</u>	<u>US/FCC</u>	<u>CAN/IC</u>
DLP-RFID2	SX9RFID2	5675A-RFID2

### 7.2 EXTERNAL ANTENNAS

The DLP-RFID2 is approved for use with an external antenna. The maximum gain allowed for the external antenna is a gain of 1.

## 7.3 FCC/IC REQUIREMENTS FOR MODULAR APPROVAL

Any changes or modifications to the DLP-RFID2's printed circuit board could void the user's authority to operate the equipment. Operation of an unapproved antenna could void the user's authority to operate the equipment.

## 7.4 WARNINGS

Operation is subject to the following two conditions: (1) This device may not cause harmful interference, and (2) this device must accept any interference received, including interference that may cause undesirable operation.

This device is intended for use under the following conditions:

1. The transmitter module may not be co-located with any other transmitter or antenna.
2. The module is approved using the FCC "unlicensed modular transmitter approval" method.

As long as these two conditions are met, further transmitter testing will not be required. However, the OEM integrator is still responsible for testing their end product for any additional compliance measures necessitated by the installation of this module (i.e. digital device emissions, PC peripheral requirements, etc.).

Note: In the event that these conditions cannot be met (i.e. co-location with another transmitter), then the FCC authorization is no longer valid, and the corresponding FCC ID may *not* be used on the final product. Under these circumstances, the OEM integrator will be responsible for re-evaluating the end product (including the transmitter) and obtaining a separate FCC authorization.

## 7.5 OEM PRODUCT LABELING

The final end product must be labeled in a visible area with the following text:

**"Contains TX FCC ID: SX9RFID2"**

## 7.6 RF EXPOSURE

In order to comply with FCC RF exposure compliance requirements, the antenna used for this transmitter must not be co-located or operating in conjunction with any other antenna or transmitter.

## 7.7 ADDITIONAL INFORMATION FOR OEM INTEGRATORS

The end user should NOT be provided with any instructions on how to remove or install the DLP-RFID2.

## **8.0 DISCLAIMER**

Neither the whole nor any part of the information contained herein nor the product described in this datasheet may be adapted or reproduced in any material or electronic form without the prior written consent of the copyright holder.

This product and its documentation are supplied on an as-is basis, and no warranty as to their suitability for any particular purpose is either made or implied. DLP Design will not accept any claim for damages whatsoever arising as a result of the use or failure of this product. Your statutory rights are not affected.

This product or any variant of it is not intended for use in any medical appliance, device or system in which the failure of the product might reasonably be expected to result in personal injury.

This document provides preliminary information that may be subject to change without notice.

## **9.0 CONTACT INFORMATION**

DLP Design, Inc.  
1605 Roma Lane  
Allen, TX 75013

Phone: 469-964-8027  
Fax: 415-901-4859  
Email: [support@dlpdesign.com](mailto:support@dlpdesign.com)  
Internet: <http://www.dlpdesign.com>





# DLP-RFID2U Demonstration Platform For the DLP-RFID2 Module

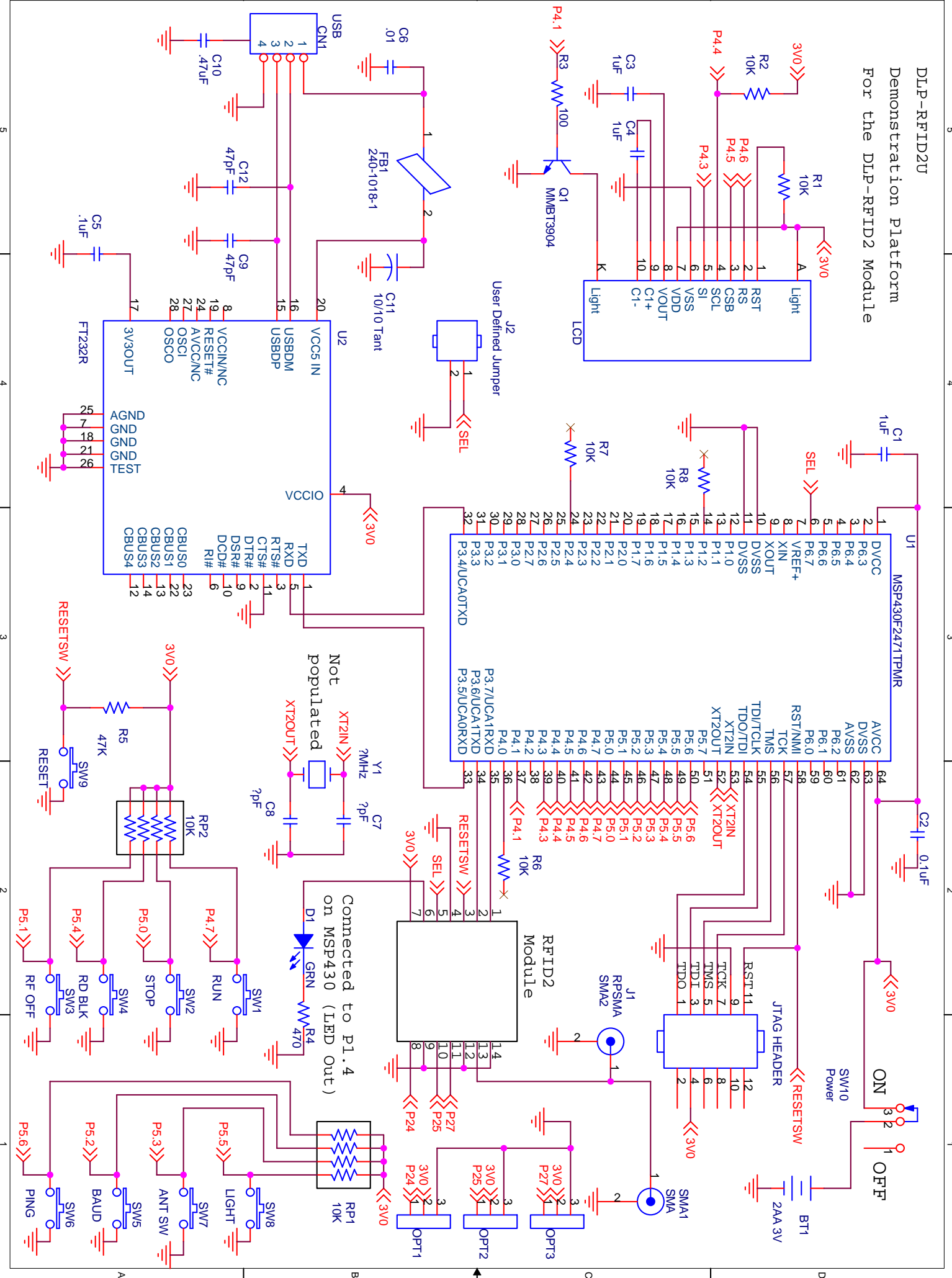

5 4 3 2 1

## X-ON Electronics

Largest Supplier of Electrical and Electronic Components

*Click to view similar products for [RFID Transponder Tools](#) category:*

*Click to view products by [DLP Design](#) manufacturer:*

Other Similar products are found below :

[DEMOKITLR](#) [SP-MX-08-HF-M2](#) [V700-A43 10M](#) [WF-SM-30](#) [V700-A44 20M](#) [V680-A81](#) [V680-A60 2M](#) [WS02-CFSC1-EV3](#) [V680-A60 5M](#) [V680-HAM91](#) [V680-A60 10M](#) [V700-A46 50M](#) [V680S-HMD66-ETN](#) [MEDP-MF-RFID-R10](#) [ST25-TAG-BAG-U](#) [MIKROE-3644](#) [ST25-TAG-BAG-E](#) [MIKROE-2395](#) [1482](#) [MIKROE-2462](#) [2800](#) [2802](#) [X-NUCLEO-NFC05A1](#) [359](#) [360](#) [361](#) [362](#) [363](#) [365](#) [3781](#) [789](#) [884](#) [4032](#) [4033](#) [4034](#) [4043](#) [4429](#) [4701](#) [AS3980-QF\\_DK\\_ST](#) [AS3930 DEMOSYSTEM](#) [AS3953-DK-TAGS](#) [ATARFID-EK1](#) [ATARFID-EK2](#) [EVB90109](#) [MIKROE-3659](#) [MIKROE-3971](#) [MIKROE-4208](#) [MIKROE-1434](#) [MIKROE-1475](#) [MIKROE-1726](#)