

| REVISIONS |                  |     |        |
|-----------|------------------|-----|--------|
| REV. NO.  | DESCRIPTION      | BY  | DATE   |
| 1         | ORIGINAL RELEASE | LMW | 3-2-87 |

**UNCONTROLLED DOCUMENT  
WILL NOT BE UPDATED**

| CONTACT       | COLOR CODE  | 30 SOL. | 28 | 26 | 24 | 22 | 20 | 18 | 16 | WIRE SIZE |
|---------------|-------------|---------|----|----|----|----|----|----|----|-----------|
| BENDIX JTR-20 | RED         |         |    |    | 1  | 2  | 3  |    |    |           |
| RC/RM24M-9    | "RC" SERIES |         |    | 2  | 3  |    |    |    |    |           |
| RC/RM20M-12   | GREEN       |         |    |    |    | 3  | 4  |    |    |           |
| RC/RM20M-13   | "RM" SERIES |         |    |    |    |    | 4  | 5  | 5  |           |
| RC/RM16M-23   | BLUE        |         |    |    |    |    |    |    |    |           |
| RC/RM28M-1    |             | 1       | 1  |    |    |    |    |    |    | SPL. NO.  |

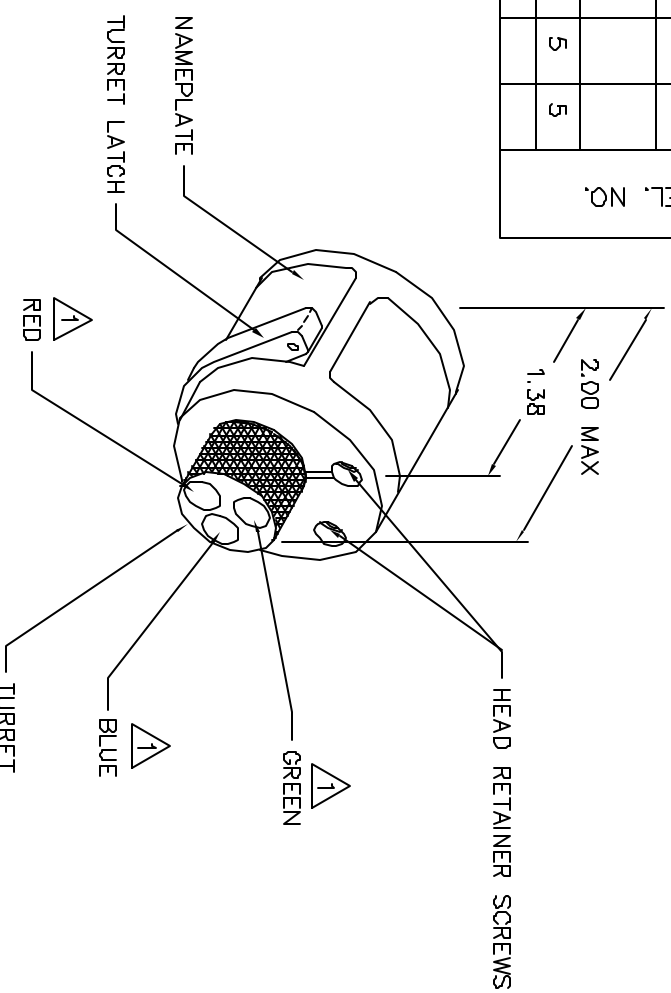
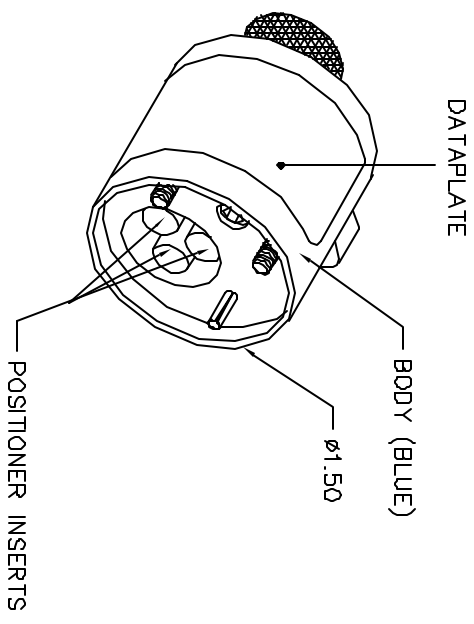

| POSITIONER COLOR | HOLE DIMENSIONS    | ADDITIONAL FEATURES |
|------------------|--------------------|---------------------|
| RED              | φ.082<br>±.84 MIN. | ┘ φ.096<br>±.050    |
| BLUE             | φ.078<br>±.84 MIN. | ┘ φ.136<br>±.305    |
| GREEN            | φ.136<br>±.415     |                     |

HOLE AND COUNTERBORE DEPTHS ARE MEASURED FROM TOP OF POSITIONER INSERTS.

|  |              |                              |                     |
|--|--------------|------------------------------|---------------------|
| RESTRICTED & CONFIDENTIAL  |              | DO NOT SCALE DRAWING         |                     |
| ITEM NO.   | PART NO.     | QTY.                         | DESCRIPTION/REMARKS |
| REV. 1   | DATE 8/21/83 |                              |                     |
| DATE 8/21/83   | DATE 8/21/83 |                              |                     |
| DATE 8/21/83   | DATE 8/21/83 |                              |                     |
| <p>NOTE: THIS DRAWING IS AN OUTLINE DRAWING OF THE RESPECTIVE INDICATED ACTUAL DIM. PART NUMBER IS DRAWING NUMBER WITHOUT THE "-ENV" SUFFIX.</p> <p>DATE 8/21/83</p> <p>DATE 8/21/83</p> <p>DATE 8/21/83</p> |              |                              |                     |
| TITLE  |              | ENVIRONMENTAL CONTROL SYSTEM |                     |
| ENVELOPE DRAWING   |              | TURRET HEAD                  |                     |
| DANIELS MANUFACTURING CORP.  |              | ORLANDO, FLORIDA             |                     |
| CASE 17851   |              |                              |                     |
| SCALE  | DATE         | BY                           | APP'D               |
| B  | TH206-ENV    |                              |                     |
| NTS  | TH206-ENV    |                              |                     |
| POSTING  | TH206-ENV    |                              |                     |
| 1  | 1            |                              |                     |

## X-ON Electronics

Largest Supplier of Electrical and Electronic Components

*Click to view similar products for [Crimpers / Crimping Tools](#) category:*

*Click to view products by [DMC](#) manufacturer:*

Other Similar products are found below :

[010-0096](#) [M225201-06](#) [M225202-37](#) [6-1579015-5](#) [CT150-6-RH07](#) [622-6441LF](#) [M322](#) [6-304052-1](#) [63456-0054](#) [63484-3701](#) [63800-8355](#)  
[63819-1875](#) [63819-2875](#) [63819-4475](#) [63823-3475](#) [63827-5375](#) [64001-0975](#) [64001-4175](#) [64005-0175](#) [662903-2](#) [690602-6](#) [7-1579001-9](#) [7-](#)  
[23471-1](#) [762637-1](#) [808714-1](#) [811242-5](#) [999-50-020083](#) [1-21002-3](#) [1-21002-7](#) [12085270](#) [1-21002-6](#) [1-21113-6](#) [1-22548-4](#) [125442-1](#)  
[DCE.91.073.BVC](#) [DCE.91.090.3MVM](#) [DCE.91.130.5MVU](#) [DCE.91.202.BVCM](#) [1338300-1](#) [1-354003-0](#) [1338301-1](#) [DF62/RE-MD](#) [142321](#)  
[1456088-1](#) [1490794-1](#) [1-45804-6](#) [1490357-2](#) [1490357-3](#) [AX100749](#) [1-59619-7](#)