

| REVISIONS |               |                  |                |                |
|-----------|---------------|------------------|----------------|----------------|
| REV. SYM. | E.C.O. NUMBER | DESCRIPTION      | BY DATE        | APP'D DATE     |
| 1         |               | ORIGINAL RELEASE | JWJ<br>2/23/05 | RRR<br>2/23/05 |

**UNCONTROLLED DOCUMENT  
WILL NOT BE UPDATED**

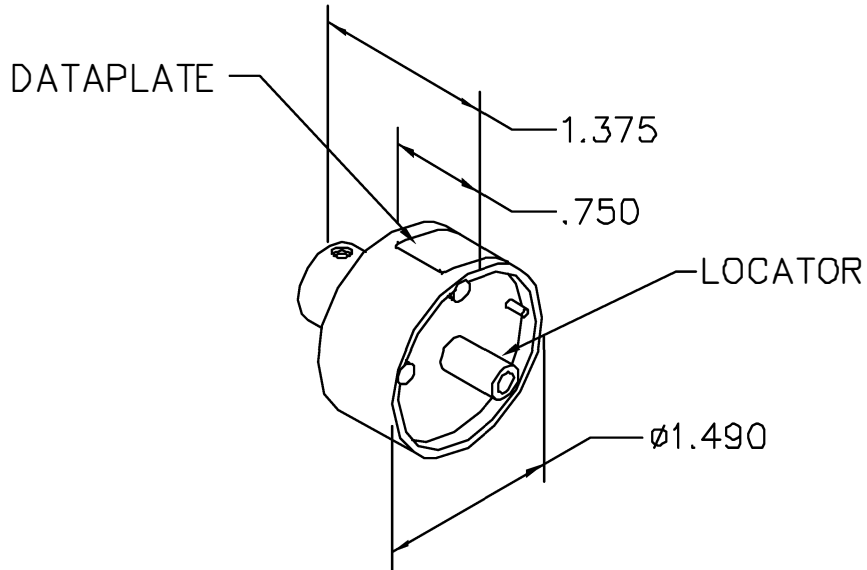

|  |    |    |         |
|--|----|----|---------|
| CONTACT                                    | 14 | 12 | WIRE    |
| ITT CANNON<br>031-0908-000<br>031-0909-000 | 1  | 1  | SEL NO. |
| USE WITH M300BT                            |    |    |         |

DATAPLATE

| LOCATOR         |                     |
|-----------------|---------------------|
| HOLE DIMENSIONS | ADDITIONAL FEATURES |
| Ø.101<br>↓.718  | □ Ø.242<br>↓.617    |

**RESTRICTED & CONFIDENTIAL**

CONFIDENTIAL PROPERTY OF DANIELS MANUFACTURING CORP. NOT TO BE DISCLOSED TO OTHERS, REPRODUCED OR USED FOR ANY OTHER PURPOSE, EXCEPT AS AUTHORIZED IN WRITING BY DANIELS MANUFACTURING. MUST BE RETURNED TO DANIELS MANUFACTURING CORP. ON COMPLETION OF ORDER OR OTHER PURPOSE FOR WHICH LENT.

**DO NOT SCALE DRAWING**

|   |          |      |         |
|---|----------|------|---------|
| DRN.  | J. JOYCE | DATE | 2/23/05 |
| CHK'D.  | RRR      | DATE | 2/23/05 |
| APP'D.  |          | DATE |         |
| APP'D.  |          | DATE |         |
| NOTE:   |          |      |         |
| THIS DRAWING IS AN OUTLINE DRAWING OF THE RESPECTIVE DMC PART NUMBER INDICATED. ACTUAL DMC PART NUMBER IS DRAWING NUMBER WITHOUT THE "-ENV" SUFFIX. |          |      |         |



DANIELS MANUFACTURING CORP.  
ORLANDO, FLORIDA  
CAGE 11851

TITLE  
**SINGLE POSITION HEAD  
ENVELOPE DRAWING**

WHERE USED:

|         |           |           |       |    |
|---------|-----------|-----------|-------|----|
| SIZE    | SCALE     | CAD P/N   | SHEET | OF |
| A       | NTS       | TP870-ENV | 1     | 1  |
| POSTING | DWG. NO.  | REV.      |       |    |
|         | TP870-ENV | 1         |       |    |

## X-ON Electronics

Largest Supplier of Electrical and Electronic Components

*Click to view similar products for [Crimpers / Crimping Tools](#) category:*

*Click to view products by [DMC](#) manufacturer:*

Other Similar products are found below :

[010-0096](#) [M225201-06](#) [M225202-37](#) [6-1579015-5](#) [CT150-6-RH07](#) [622-6441LF](#) [M322](#) [6-304052-1](#) [63456-0054](#) [63484-3701](#) [63800-8355](#)  
[63819-1875](#) [63819-2875](#) [63819-4475](#) [63827-5375](#) [64001-0975](#) [64001-4175](#) [64005-0175](#) [662903-2](#) [690602-6](#) [7-1579001-9](#) [7-23471-1](#)  
[762637-1](#) [808714-1](#) [811242-5](#) [999-50-020083](#) [1-21002-3](#) [1-21002-7](#) [12085270](#) [1-21002-6](#) [1-21113-6](#) [1-22548-4](#) [125442-1](#)  
[DCE.91.073.BVC](#) [DCE.91.090.3MVM](#) [DCE.91.130.5MVU](#) [DCE.91.202.BVCM](#) [1338300-1](#) [1-354003-0](#) [1338301-1](#) [DF62/RE-MD](#) [142321](#)  
[1456088-1](#) [1490794-1](#) [1-45804-6](#) [1490357-2](#) [1490357-3](#) [AX100749](#) [1-59619-7](#) [1596970-1](#)