

0221562

- According to
 - SIL-Claimed Level (SIL CL) 3 to EN 62061
 - Performance Level (PL) e to DIN EN ISO 13849-1
 - Category 4 to EN 954-1
- Output: max. 6 NO, 1 NC contacts or 1 NO contact for AC 250 V
- Optionally with release delayed NO contact to 10 min
- 1-channel or 2-channel connection
- Line fault detection at On pushbutton
- Optionally automatic On function after connection of operating voltage or activation via On pushbutton
- Optionally cross fault detection in emergency stop control circuit
- Optionally dual voltage version
- Feedback circuit X1-X2 for monitoring external contactors
- Integrated short-circuit and overvoltage protection
- Optionally with protective separation to IEC/EN 60 140, IEC/EN 60 947-1
- LED displays for channels 1 and 2 and supply
- Removable terminal strips
- Wire connection: also 2 x 1,5 mm² stranded ferruled (isolated), DIN 46 228-1/-2/-3-4 or 2 x 2,5 mm² stranded ferruled DIN 46 228-1/-2/-3
- Width 100 mm

Function diagram

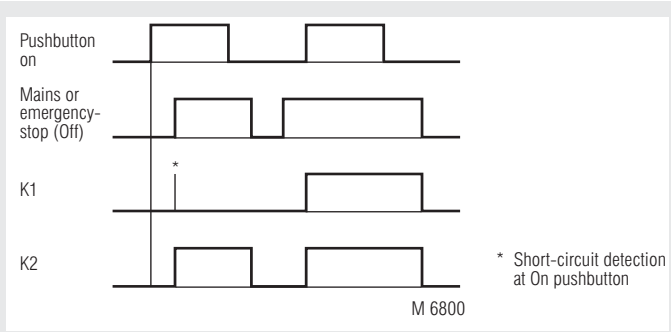

Approvals and marking



BG valid 31.12.2009; ¹⁾ pending; * see variants

Block diagram

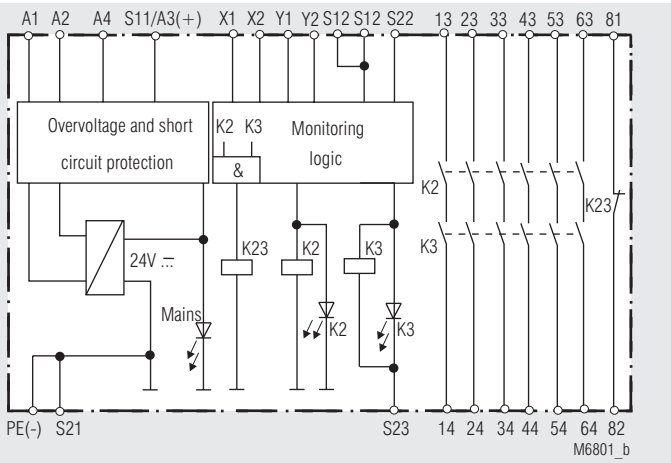

Applications

- Protection of people and machines
- Emergency stop circuits on machines
- Monitoring of safety gates

Indication

- LED power supply: on, when operating voltage present
- LED K2: on, when supply on relay K2
- LED K3: on, when supply on relay K3

only at BO 5988/4_ __,
BO 5988/5_ __:
LED KT2, KT3: on, when delayed contacts are energised

Note

Safety category 4 according to EN 954-1 only at applications with cross fault detection.
At delayed contacts: Safety category 3 according to EN 954-1 for delays up to 30 s max. For longer delays category 1.

Circuit diagrams

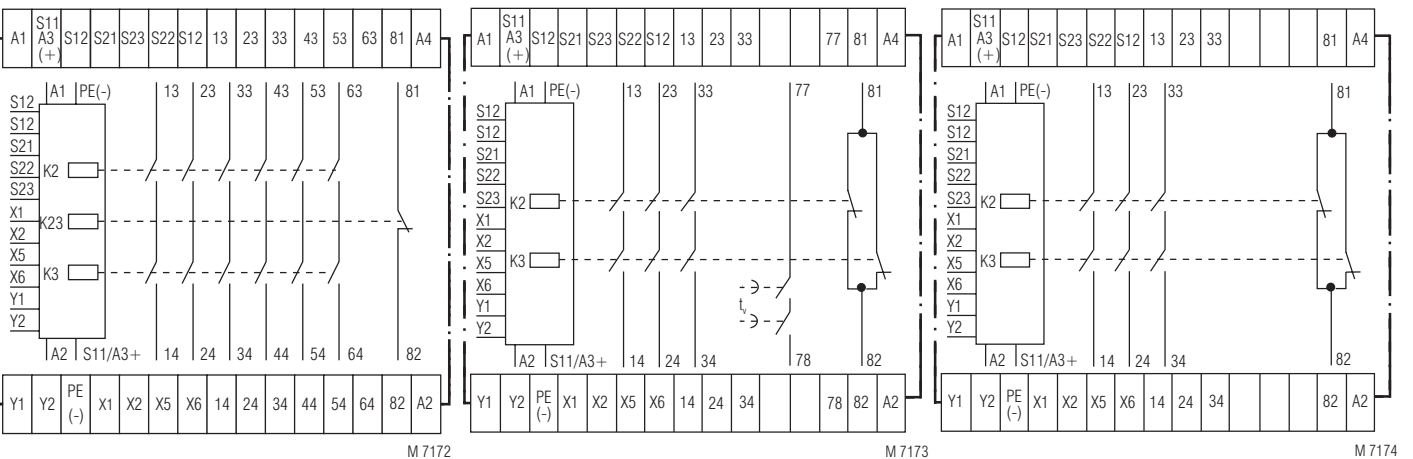

BO 5988.61

BO 5988.47

BO 5988.48

Notes

Jumper assignment for functions:
Activation via On pushbutton / or automatic On function

On push-button Y1 - Y2	Jumper X5 - X6	Function
		The output contacts are switches only after operation of the On pushbutton. Line fault monitoring at the On pushbutton
		Automatic On function for operating voltage Off/On or after emergency stop release

Line fault detection at the On pushbutton:

The output contacts cannot be closed if the On pushbutton is already closed before the voltage is applied to S12, S22 (also in the event of a line fault at the On pushbutton).

A line fault at the On pushbutton which occurs after activation of the device is recognized when switching-on takes place again and closing of the output contacts is then prevented.

If a line fault occurs at the On pushbutton after the voltage is already present at S12, S22, undesired activation will take place, because this line fault does not differ from the normal closing function.

The gold-plated contacts of the BO 5988 also mean that this module is suitable for switching small loads of 1 mVA ... 7 VA, 1 mW ... 7 W in the range 0,1 ... 60 V, 1 ... 300 mA. The contacts also permit the maximum switching current. However, since the gold plating is burnt off at this current level, the device is no longer suitable for switching small loads after this.

The PE terminal permits operation of the device in IT systems with insulation monitoring and also serves as a reference point for testing the control voltage. The internal short-circuit protection will be bridged on DC devices, if the protective ground is connected to terminal PE.

One or more extension modules BN 3081 or external contactors with positively-driven contacts may be used to multiply the number of contacts of the emergency stop module BO 5988.

ATTENTION - AUTOMATIC START!



According to IEC/EN 60 204-1 part 9.2.5.4.2 it is not allowed to restart automatically after emergency stop. Therefore the machine control has to disable the automatic start after emergency stop.

Technical data

Input

Nominal voltage U_N

BO 5988.--/00:	DC 24 V
BO 5988.--/24:	DC 24 V ¹⁾ + AC 24 V ²⁾
	DC 24 V ¹⁾ + AC 48 V ²⁾
	DC 24 V ¹⁾ + AC 110 V ²⁾
	DC 24 V ¹⁾ + AC 230 V ²⁾
	DC 24 V ¹⁾ + AC 240 V ²⁾
	¹⁾ at terminals A3-A4
	²⁾ at terminals A1-A2

Voltage range:

at 10 % residual ripple:

at 48 % residual ripple:

Nominal consumption:

Nominal frequency:

Control voltage

at S11:

at S21:

Control current:

Minimum voltage

at terminals S12, S22:

Recovery time:

DC 24 V
DC 24 V ¹⁾ + AC 24 V ²⁾
DC 24 V ¹⁾ + AC 48 V ²⁾
DC 24 V ¹⁾ + AC 110 V ²⁾
DC 24 V ¹⁾ + AC 230 V ²⁾
DC 24 V ¹⁾ + AC 240 V ²⁾
¹⁾ at terminals A3-A4
²⁾ at terminals A1-A2
AC 0,8 ... 1,1 U_N
DC 0,9 ... 1,2 U_N
DC 0,8 ... 1,1 U_N
AC: approx. 6 VA, DC: approx. 3 W
50 / 60 Hz

typ. DC + 24 V

0 V

typ. DC 110 mA

DC 21 V with activated device

2 s

A minimum switch-off time of 20 s must be observed if the line fault monitoring function at the On pushbutton is active

Technical Data

Output

Contact

BO 5988.48:	3 NO, 1 NC indicator contact
BO 5988.61:	6 NO, 1 NC indicator contact
BO 5988.62:	6 NO, 1 NO indicator contact
BO 5988.47:	3 NO, 1 NC indicator contact 1 NO release delayed

The NO contacts 13...63 / 14...64 are safety contacts. The NO contact 77/78 can be use as safety contact for units with time delay up to max. 30 s.

ATTENTION! The NC contacts 81-82 or one NO contact 83-84 can only be used for monitoring.

Operate time

manual restart: typ. 30 ms

automatic restart: 1 s

Release time

opening in secondary circuit

(S12-S22): 30 ms ± 50 %

opening in supply circuit

BO5988.47, BO 5988.48: 100 ms + 50 %

BO 5988.61, BO 5988.62: 50 ms + 50 %

Time delay t_v :

BO 5988.47/1 __: Auxiliary supply is not necessary during elapse of time:

0,1 ... 1 s 0,3 ... 3 s

BO 5988.47/2 __: 1 s, 3 s, 5 s, 10 s

1 ... 10 s 1 ... 10 s

BO 5988.47/4 __: Auxiliary supply must be connected during elapse of time:

0,1... 1 s 0,1 ... 1 min

0,3... 3 s 0,3 ... 3 min

1 ... 10 s 0,5 ... 5 min

3 ... 30 s 1 ... 10 min

BO 5988.47/5 __: 1 s, 3 s, 10, 30 s

1 min, 3 min, 5 min, 10 min

Repeat accuracy

BO 5988.47/1 __ and

BO 5988.47/2 __: ± 15 % of setting value

BO 5988.47/4 __ and

BO 5988.47/5 __: ± 1 % of setting value

Relay, positively-driven

AC 250 V

Nominal output voltage:

DC: see limit curve for arc-free operation

Signalling contact of

BO 5988.61 and BO 5988.62: AC 10 ... 250 V, DC 10 ... 120 V

for AC/DC 0,1 ... 1 A

see total current limit curve

(max. 10 A in one contact path)

Thermal current I_{th} :

release delayed NO contact

77-78 at BO 5988.47:

max. 8 A

Switching capacity

to AC 15

NO contact:

5 A / AC 230 V

IEC/EN 60 947-5-1

NC contact:

2 A / AC 230 V

IEC/EN 60 947-5-1

BO 5988.47

release delayed NO contact:

3 A / AC 230V

IEC/EN 60 947-5-1

to DC 13

NO contact:

4 A / DC 24 V

IEC/EN 60 947-5-1

NC contact:

4 A / DC 24 V

IEC/EN 60 947-5-1

to DC 13

NC contact:

10 A / 24 V > 10⁵

On: 0,4 s, Off: 9,6 s

Electrical life

to AC 15 at 2 A, AC 230 V:

10⁵ switching cycles IEC/EN 60 947-5-1

to DC 13 at 2 A, AC 230 V:

> 240 x 10³ switching

cycles IEC/EN 60 947-5-1

Permissible operating

frequency:

600 switching cycles / h

Short circuit strength

max. fuse rating:

6 A gL

IEC/EN 60 947-5-1

max. line circuit breaker:

C 10 A

Mechanical life:

30 x 10⁶ switching cycles

Technical Data

General Data

Operating mode:	Continuous operation	
Temperature range:	- 15 ... + 50°C	
Clearance and creepage distances		
rated impuls voltage / pollution degree:	4 kV / 2	IEC 60 664-1
EMC		
Electrostatic discharge:	8 kV (air)	IEC/EN 61 000-4-2
HF irradiation:	10 V / m	IEC/EN 61 000-4-3
Fast transients:	2 kV	IEC/EN 61 000-4-4
Surge voltages between wires for power supply:	0,5 kV	IEC/EN 61 000-4-5
between wire and ground:	2 kV	IEC/EN 61 000-4-5
HF-wire guided:	10 V	IEC/EN 61 000-4-6
Interference suppression:	Limit value class B	EN 55 011
Degree of protection		
Housing:	IP 40	IEC/EN 60 529
Terminals:	IP 20	IEC/EN 60 529
Housing:	Thermoplastic with V0 behaviour according to UL subject 94	
Vibration resistance:	Amplitude 0,35 mm IEC/EN 60 068-2-6 frequency 10 ... 55 Hz	
Climate resistance:	15 / 050 / 04 IEC/EN 60 068-1	
Terminal designation:	EN 50 005	
Wire connection:	1 x 4 mm ² solid or 1 x 2,5 mm ² stranded ferruled (isolated) or 2 x 1,5 mm ² stranded ferruled (isolated) DIN 46 228-1/-2/-3/-4 or 2 x 2,5 mm ² stranded ferruled DIN 46 228-1/-2/-3	
Wire fixing:	Plus-minus terminal screws M 3,5 box terminal with wire protection	
Mounting:	DIN rail IEC/EN 60 715	
Weight:	850 g	

Dimensions

Width x height x depth: 100 x 74 x 121 mm

Safety related data

Probability of dangerous Failure per Hour (PFH_D):	4,77 · 10 ⁻¹⁰ 1/h (BO 5988.61, BO 5988.62) 8,60 · 10 ⁻¹⁰ 1/h (BO 5988.47/124)
Safe Failure Fraction (SFF):	99,4 % (BO 5988.61, BO 5988.62) 99,3 % (BO 5988.47/124)
Proof Test Intervall (T1):	20 Years



The values stated above are valid for the standard type. Safety data for other variants are available on request

Standard types

BO 5988.61/024	DC 24 V + AC 230 V	50 / 60 Hz	
Article number:	0040375		stock item
<ul style="list-style-type: none"> • Dual voltage version • Output: 6 NO contacts, 1 NC contact as monitoring contact • Width: 100 mm 			
BO 5988.47/124	DC 24 V + AC 230 V	50 / 60 Hz	1 ... 10 s
Article number:	0040430		stock item
<ul style="list-style-type: none"> • Dual voltage version • Output: 3 NO contacts, 1 NC contact as monitoring contact, 1 release delayed NO contact • With adjustable time delay t_v to 10 s • Width: 100 mm 			

Variants

BO 5988. __ / 60:	with CSA approval
BO 5988. __ / 61:	with UL approval (Canada/USA)
Auxiliary supply is not necessary during elapse of time:	
BO 5988.47 / 1 __:	3 NO / 1 NC contacts + t_v adjustable
BO 5988.47 / 2 __:	3 NO / 1 NC contacts + t_v fixed
Auxiliary supply must be connected during elapse of time:	
BO 5988.47 / 4 __:	3 NO / 1 NC contacts + t_v adjustable
BO 5988.47 / 5 __:	3 NO / 1 NC contacts + t_v fixed
Without time delay t_v :	
BO 5988.48 / 0 __:	3 NO / 1 NC contacts
BO 5988.61 / 0 __:	6 NO / 1 NC contacts as monitoring contact
BO 5988.62 / 0 __:	6 NO / 1 NC contacts as monitoring contact
BO 5988. __ / __00:	single voltage model
BO 5988. __ / __24:	dual voltage model
BO 5988.61 / 106:	
Protective separation of control and load circuits according to IEC/EN 61 140, IEC/EN 60 947 4 kV / 2 referred to overvoltage category II with basic insulation to IEC 60 664 of 2,5 kV / 2.	
BO 5988.61 / 324:	Dual voltage model 0,5 s operate delay with automatic restart

Ordering example for variants

BO 5988.47/124	1 ... 10 s	DC 24 V + AC 230 V	50 / 60 Hz	
				Nominal frequency
				Nominal voltage
				Time delay
				00: 1 nominal voltage
				24: 2 nominal voltages
				0: without t_v
				without auxiliary supply during time elapse:
				1: t_v adjustable
				2: t_v fixed
				with auxiliary supply during time elapse:
				4: t_v adjustable
				5: t_v fixed
				Contacts
				Type

Characteristics

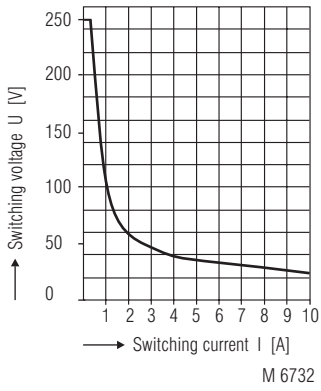

Limit curve for arc-free operation with resistive load

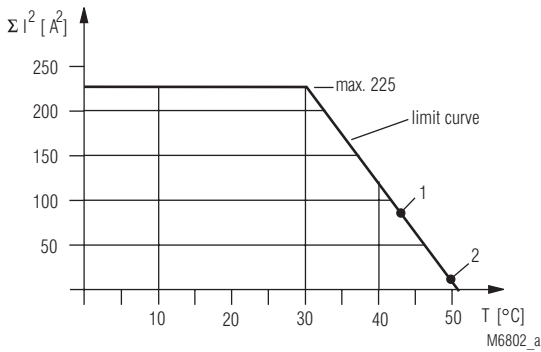

Total current limit curve

It is necessary to use the square of the currents in order to obtain a linear limit curve.

General formula for determination of the maximum ambient temperature

- Sum of currents² per safety contact = value on scale ΣI^2 (A²)
- Max. ambient temperature T = Cross point of scale ΣI^2 (A²) with limit curve

Example 1

- $(4A)^2 + (4A)^2 + (4A)^2 + (4A)^2 + (4A)^2 + (4A)^2 = 96 A^2$ (Scale ΣI^2)
- Max. ambient temperature $T = 43^\circ\text{C}$ (point 1)

Example 2

- $(0,5 A)^2 + (1 A)^2 + (2 A)^2 + (1 A)^2 = 6,25 A^2$ (Scale ΣI^2)
- Max. ambient temperature $T = 49^\circ\text{C}$ (point 2)

Please note:

The total current² can still be 1,5 A² at 50°C, i.e. 0,5 A per safety contact

- $(0,5 A)^2 + (0,5 A)^2 + (0,5 A)^2 + (0,5 A)^2 + (0,5 A)^2 + (0,5 A)^2 = 1,5 A^2$
- Max. ambient temperature = 50°C

Application examples

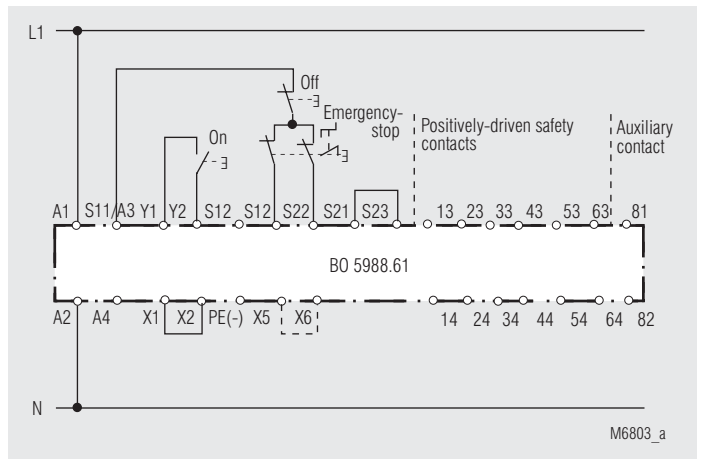

Two-channel emergency stop circuit without cross fault detection.

Activation via On pushbutton. - - - Jumper X5 - X6:

A jumper must be fitted X5 - X6 for the automatic On function.

The On pushbutton is not required.

Application examples

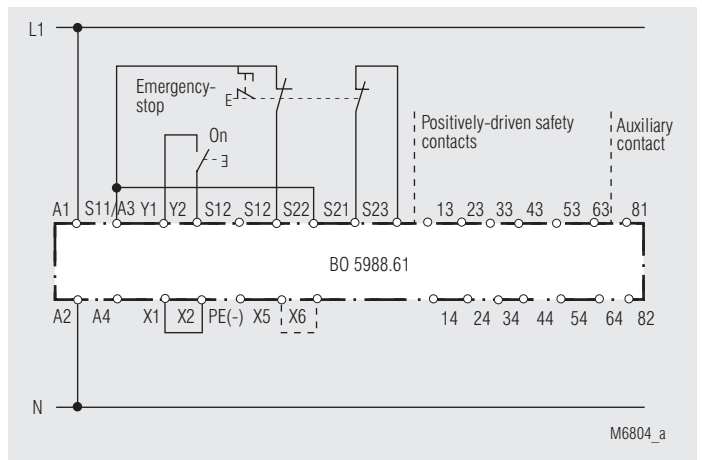

Two-channel emergency-stop circuit with cross fault detection.

Activation via On pushbutton. - - - Jumper X5 - X6:

A jumper must be fitted X5 - X6 for the automatic On function.

The On pushbutton is not required.

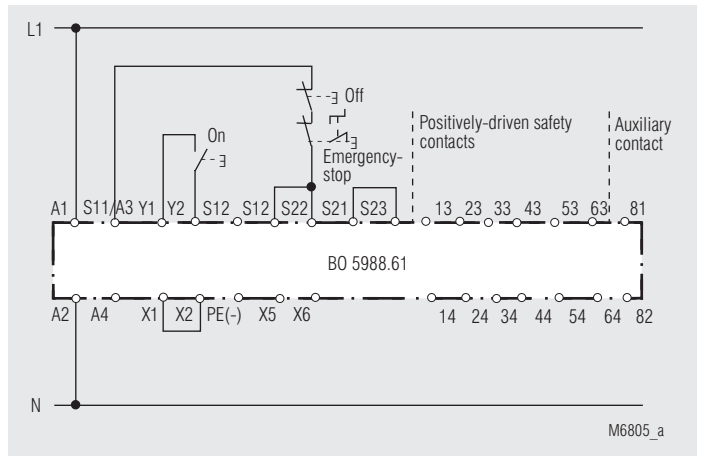

One-channel emergency stop circuit. This circuit does not have any redundancy in the emergency stop control device circuit.

Application examples

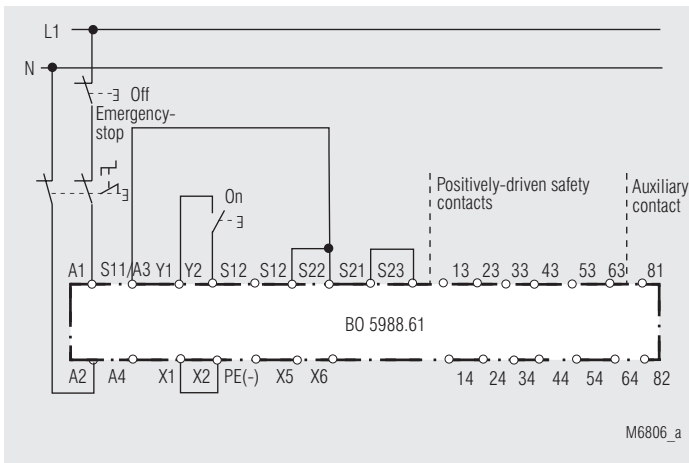

Two-pole emergency stop circuit with emergency stop control device in the supply circuit.

Application for long emergency stop loops where the control voltage drops below the minimum voltage of 21 V.

Attention:

Single faults (e.g. line faults at the emergency stop control device) are not detected with this external circuit configuration.

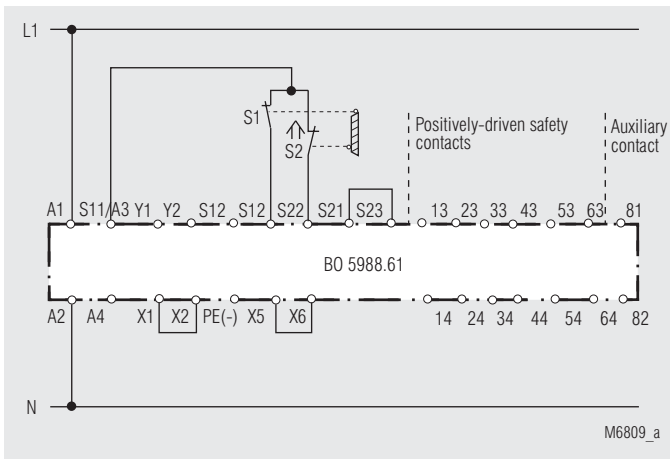

Two-channel monitoring of a safety gate. S1 must not close before S2

Application examples

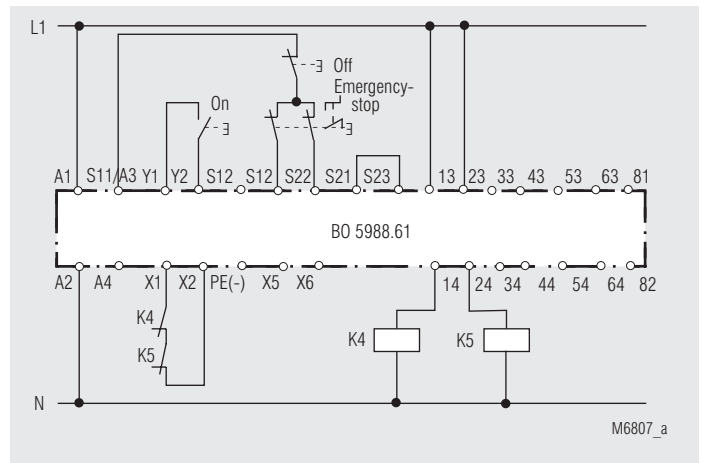

Contact reinforcement by external contactors, two-channel.

The output contacts can be reinforced by external contactors with positively-driven contacts for switching currents > 8 A. Functioning of the external contactors is monitored by looping the NC contacts into the closing circuit (terminals X1 - X2).

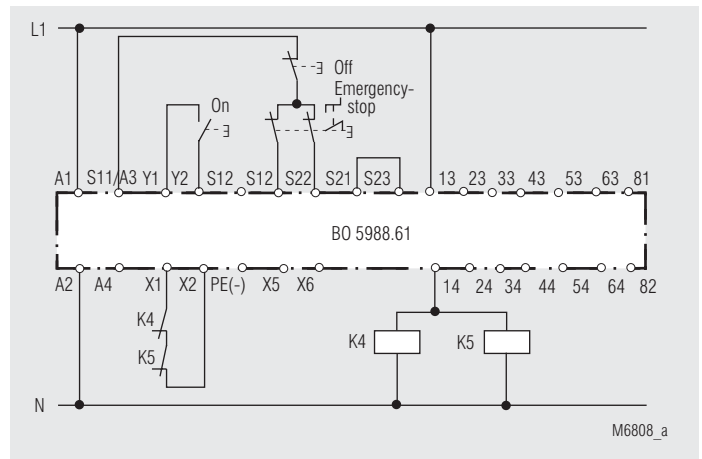

Contact reinforcement by external contactors with reduced safety level.

X-ON Electronics

Largest Supplier of Electrical and Electronic Components

Click to view similar products for [Safety Relays](#) category:

Click to view products by [Dold & Soehne](#) manufacturer:

Other Similar products are found below :

[7-1618103-5](#) [1351-1X](#) [1618089-2](#) [C200HDA003](#) [C200HMR432](#) [C200HMR832](#) [C200HMR833](#) [20-050-36X](#) [C500OD415CN](#) [2-1618068-0](#)
[25994](#) [9-1618103-2](#) [SP10-ETL01](#) [21-890](#) [3-1618060-0](#) [C200HNC112](#) [C200HOD214](#) [C500CN812N](#) [1100X](#) [1100-42X](#) [1-1618062-0](#) [6-](#)
[1618082-4](#) [7-1618103-6](#) [50.12.9.110.1000](#) [SP16DRD](#) [SP16DRA](#) [XPSAXE5120P](#) [XPSECPE5131P](#) [C500-CE243](#) [607.5111.020](#) [439390016](#)
[607.5111.009](#) [607.5111.010](#) [PSR-MM25-1NO-2DO-24DC-SC](#) [NXSL5500](#) [600PSR-165/300-CU](#) [SR4D4110](#) [J73KN-AM-22](#) [G7SA-3A1B](#)
[DC12](#) [G7SA-4A2B](#) [DC12](#) [G7SA-3A1B](#) [DC48](#) [G7SA-2A2B](#) [DC48](#) [ES-FA-9AA](#) [50.12.9.024.5000](#) [44510-2310](#) [V23047-A1036-A501](#) [44510-](#)
[1081](#) [44510-2021](#) [44510-2232](#) [WUF-12-5060-T](#)