

High Precision CC/CV Primary-Side Converter

Description

The DK935 is a high performance CC/CV primary-side AC-DC converter chip. With 850V high voltage switch power transistor integrated, it can detect primary side peak current. It operates in primary-side sensing and regulation, so opto-coupler and TL431 could be eliminated. It also integrated primary-side feedback constant current, constant voltage, self-power supply circuit and output cable compensation circuit. It is designed with highly integrated CMOS circuit, with few external components and simple transformer design. The isolated output circuit transformer needs only two windings.

Main Features

- Global voltage input 85V-265V
- Built-in 850V high voltage power BJT
- Internal integrated high voltage constant current start-up circuit, no need of additional start-up resistor
- Patented self-power supply design without auxiliary winding
- Support applications of two-winding and three-winding
- Output line loss compensation technology can effectively compensate the loss voltage drop of the output current on the output line
- Built-in PWM oscillating circuit and frequency jittering function for improved EMI performance
- RCD absorption can be omitted on the primary side
- $\pm 5\%$ CV accuracy, $\pm 8\%$ CC accuracy
- Over temperature, over voltage, over current, short circuit Protection
- 4KV ESD
- Package: SOP-7

Applications

- AC-DC power adapters for shaver, mobile phone, PDA, MP3 and other portable devices
- Standby or auxiliary power supply for household appliances and personal computers
- LED power supply
- Replace linear power supply or RCC switching mode power supply

PINS Array

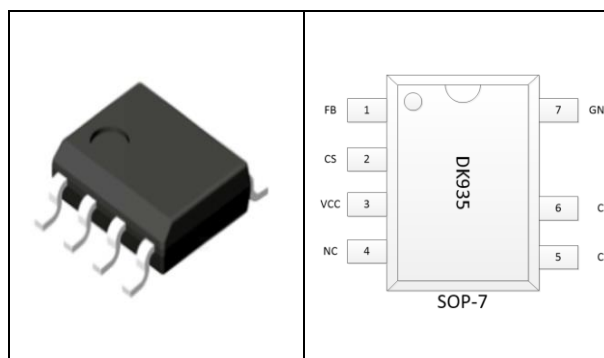

Ordering Information

Product Model	Package Type	Package Information	Silk Screen
DK935	SOP-7	4000 pieces per plate	DK935 XXXX

PIN Function

Pin No.	Pin Name	Function
1	FB	Primary feedback pin
2	CS	Max peak current setting pin, connected with resistance to ground externally
3	VCC	Power supply pin, connected with a capacitor of 10uF-47uF to ground externally
4	NC	Floating
5,6	C	Collector of Power transistor
7	GND	Ground pin

Function Structure Diagram

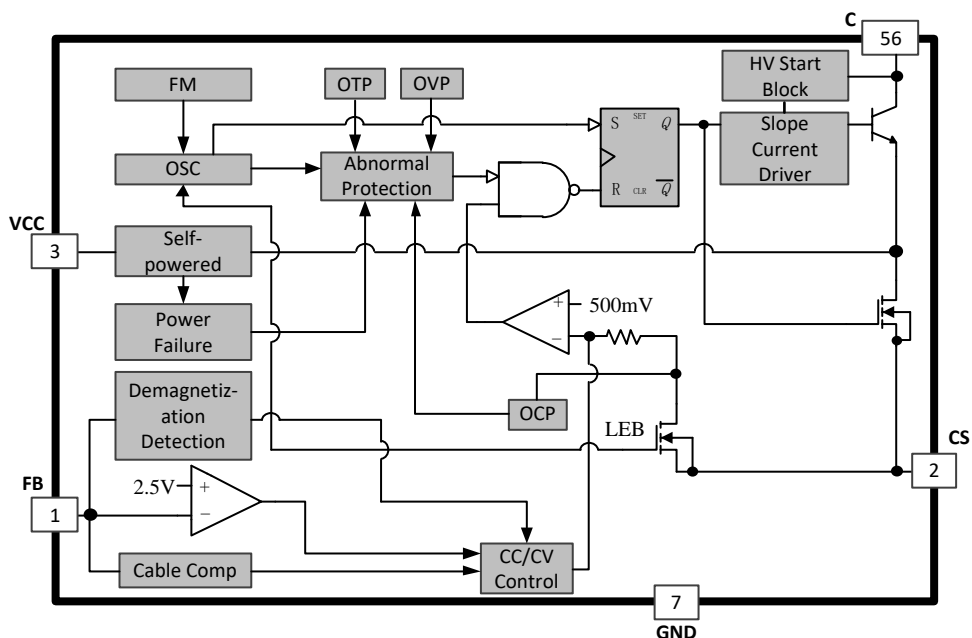

Typical Power

Product Model	Input Voltage	Typical Power
DK935	85-265VAC	5W

Remark: Test typical power in closed environment @45°C ambient temperature.

Absolute Maximum Rating

Parameter	Symbol	Min	Typ	Max	Unit
Power supply voltage VCC	U_S	-0.3		7	V
Power supply current VCC	I_S		100		mA
Pin Voltage	U_{PV}	-0.3		VCC+0.3	V
Breakdown Voltage	U_{PP}	-0.3		850	V
Peak Current	I_{PEAK}			400	mA
Total Dissipation Power	P_{TOT}		450		mW
Operating Temperature	T_R	-25		135	°C
Storage Temperature	T_{STG}	-55		150	°C
Soldering Temperature	T_W		280/5S		°C
ESD	ESD		4000		V

Electrical Characteristics ($T_A=25^\circ\text{C}$, Special circumstances shall be specified separately)

Parameter	Test Condition	Min	Typ	Max	Unit
VCC operating voltage	AC input 85V-265V	4.5	5.0	5.5	V
VCC start-up threshold voltage	AC input 85V-265V	4.5	5.0	5.5	V
VCC restart voltage	AC input 85V-265V	3.0	3.3	3.6	V
VCC protect voltage	AC input 85V-265V	5.8	6.2	6.6	V
VCC operating current	VDD=5V, FB=2V			40	mA
HV Start-up current	AC input 265V			0.5	mA
Start-up time	AC input 85V			500	ms
BJT Voc breakdown voltage	$I_{OC}=1\text{mA}$	850			V
IS max turn-on voltage	VDD=5V	450	500	550	mV
CV reference voltage	VDD=5V	2.45	2.5	2.55	V
Max BJT current	VDD=5V			450	mA
Operating frequency	VDD=5V	0.5		80	KHz
Short circuit protection threshold	VDD=5V, Measure FB voltage		1.2		V
Open circuit protection voltage	VDD=5V, Measure FB voltage		3.7		V
Temperature protection	VDD=5V	130	135	140	°C
Min turn-on time	VCC=5V		500		ns

Operation Principle

1. Start up

With HV start-up current source integrated in the chip, external VCC capacitor would be charged when power on. When VCC voltage reaches 5V, the start-up procedure ends and the chip enters the soft start stage.

2. CC mode

The chip sets primary maximum peak current ($I_p = 500\text{mV}/R_{is}$). When the load exceeds maximum output power, the chip operates in CC mode.

$$\text{Output current: } I_o = \frac{1}{4} * I_p * \frac{N_p}{N_s}$$

3. CV mode

During the fly-back stage, the chip detects output voltage (V_o) indirectly by detecting FB voltage. FB voltage and internal 2.5V reference are used for error amplification. The output of the error amplifier controls the PWM switching frequency to stabilize the output voltage (V_o) according to the load condition. The output voltage (V_o) of the three-winding application is expressed as follows:

$$V_o = 2.5V * \frac{N_s}{N_a} * \left(1 + \frac{R_{fb2}}{R_{fb1}}\right) - V_d. \quad V_d \text{ is the secondary rectifier diode voltage.}$$

The output voltage (V_o) of the two-winding application is expressed as follows:

$$V_o = 2.5V * \frac{N_s}{N_p} * \left(1 + \frac{R_{fb2}}{R_{fb1}}\right) - V_d. \quad V_d \text{ is the secondary rectifier diode voltage, other parameters can}$$

refer to the typical application.

4. Cable compensation

The cable compensation technology can compensate the loss voltage drop of the output line. When the load decreases from full load to no load, the line loss compensation voltage also decreases linearly. The compensation voltage can be set through the FB divider resistor, the specific formula is:

Three-winding application: the line compensation voltage at the output is:

$$V_{COMP} = I_{COMP} * R_{FB2} * \frac{N_s}{N_A}, \quad \text{Line loss compensation current } I_{COMP} \quad I_{COMP(max)}=16\mu\text{A};$$

Two-winding application: the line compensation voltage at the output is:

$$V_{COMP} = I_{COMP} * R_{FB2} * \frac{N_s}{N_P}.$$

5. Protection

DK935 has various self-protection functions, such as output open-circuit protection, output short-circuit protection, VCC under-voltage protection, VCC over-voltage protection, over-temperature protection, etc.

Typical Application Schematic

Two-winding application:

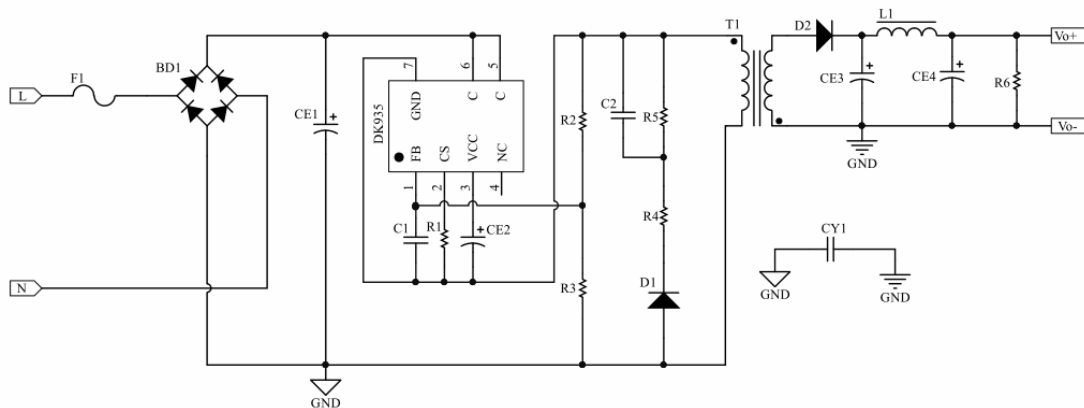

Three-winding application:

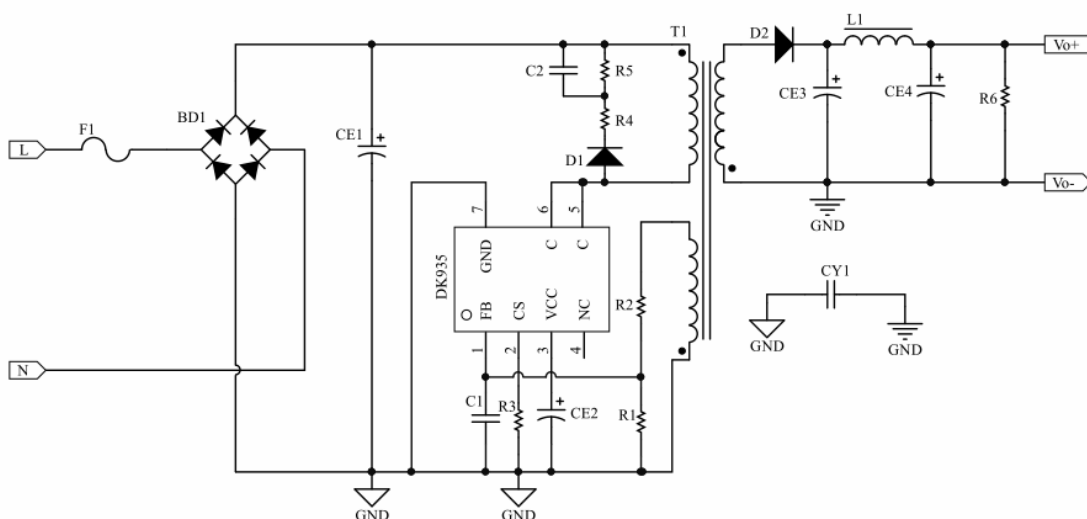

Package Information and Dimensions

1. SOP-7 Package Information

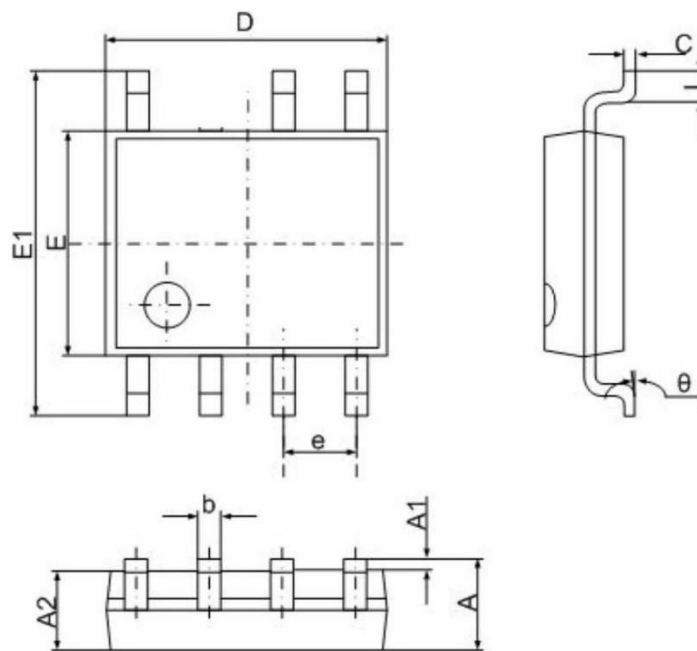

符号	尺寸单位: mm	
	最小	最大
A	1.350	1.750
A1	0.100	0.250
A2	1.350	1.550
b	0.330	0.510
c	0.170	0.250
D	4.700	5.100
E	3.800	4.000
E1	5.800	6.200
e	1.270(BSC)	
L	0.400	1.270
θ	0°	8°

2. Tape and Reel Information

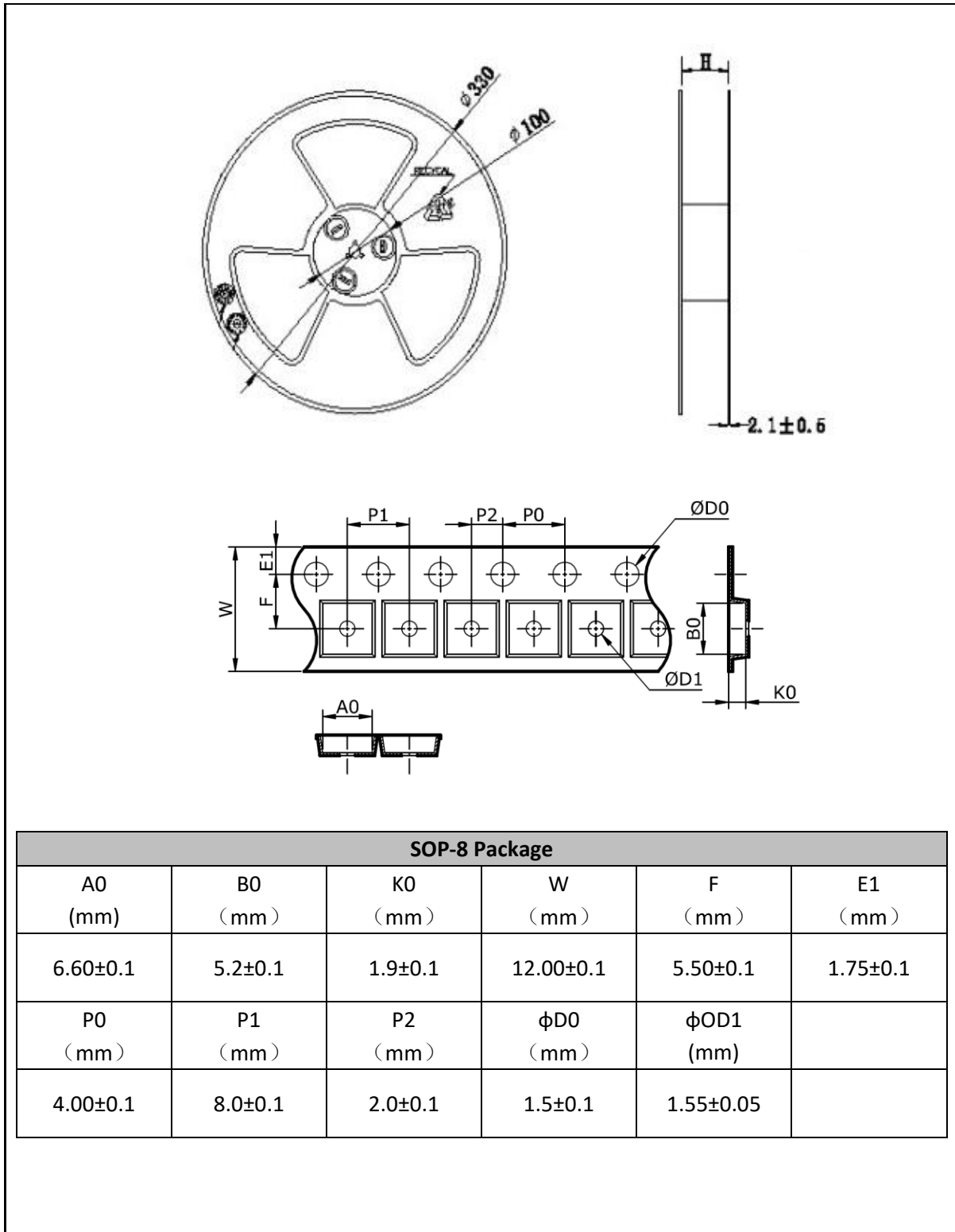



Caution: This product is a static sensitive component, please pay attention to protecting! The scope of ESD damage can be extended from minor performance to equipment failure. Precision chip may be damaged, which may result in component parameters not meeting the published specifications.

- Thanks for using our products. We recommend that you read the specifications carefully before using.
- Dongke Semiconductor Co., Ltd reserves the right of change specifications without prior notice.
- Dongke Semiconductor Co., Ltd assumes no liability for any use of its products for special purposes.
- Dongke Semiconductor Co., Ltd has no obligation to support the use and application of products for special purposes.
- Dongke Semiconductor Co., Ltd will not transfer its patents and any other relevant licensing rights.
- Any semiconductor product may fail or break down under certain conditions. The buyer is responsible to abide by safety standards and take safety measures when designing and manufacturing applications using products of Dongke Semiconductor Co., Ltd to avoid potential failure risk which may cause personal injury or property loss.
- Product improvement is endless, and our company will wholeheartedly provide customers with better products.

X-ON Electronics

Largest Supplier of Electrical and Electronic Components

Click to view similar products for [Switching Voltage Regulators](#) category:

Click to view products by [DongKe](#) manufacturer:

Other Similar products are found below :

[FAN53610AUC33X](#) [FAN53611AUC123X](#) [EN6310QA](#) [160215](#) [R3](#) [KE177614](#) [FAN53611AUC12X](#) [MAX809TTR](#) [AST1S31PUR](#)
[NCP81103MNTXG](#) [NCP81203PMNTXG](#) [NCP81208MNTXG](#) [PCA9412AUKZ](#) [NCP81109GMNTXG](#) [NCP81109JMNTXG](#) [MP2161AGJ-Z](#)
[NCP81241MNTXG](#) [MPQ4481GU-AEC1-P](#) [MP8756GD-P](#) [MPQ2171GJ-P](#) [MPQ2171GJ-AEC1-P](#) [MP2171GJ-P](#) [NCV1077CSTBT3G](#)
[MP28160GC-Z](#) [MPM3509GQVE-AEC1-P](#) [XDPE132G5CG000XUMA1](#) [MP5461GC-P](#) [IR3888AMTRPBFAUMA1](#) [MPQ4409GQBE-AEC1-](#)
[P](#) [S-19903DA-A8T1U7](#) [S-19903CA-A6T8U7](#) [S-19903CA-S8T1U7](#) [S-19902BA-A6T8U7](#) [S-19902CA-A6T8U7](#) [AP7361EA-SPR-13](#)
[AP7361EA-33DR-13](#) [S-19902AA-A6T8U7](#) [S-19903AA-A6T8U7](#) [S-19902AA-S8T1U7](#) [S-19902BA-A8T1U7](#) [AU8310](#) [LMR36503R5RPER](#)
[LMR36503RFRPER](#) [LMR54406DBVR](#) [XC9110C301MR-G](#) [XC9141A50CMR-G](#) [XCL206F083CR-G](#) [XCL210A111GR-G](#)
[LTM4663EV#PBF](#) [LD5537B1GL](#)