

Doodle Labs Mini OEM Mesh Rider Radio - 5650~5755 MHz (Japan Robotics)

Overview

The Mini OEM Mesh Rider Radio is an advanced Manet router. The 5700-MHz Japan Unmanned UAV Band Mini OEM Mesh Rider Radio is an extension of the custom development of the radio platform sponsored by the Department of Defense. The 5700-MHz Mini OEM Mesh Rider Radio is certified under Article 2-1-72, "Unmanned Mobile Image Transmission System".

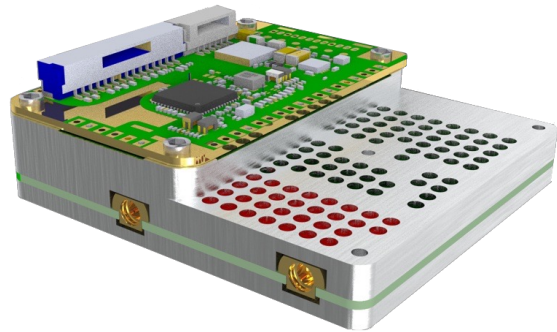

The 5700-MHz Mini OEM Mesh Rider Radio employs Doodle Labs' patented Mesh Rider® technology with state-of-the-art RF and networking capabilities that enable communication further, faster, and more reliably than any comparable solution on the market. For example, optimized video streaming carries crystal clear 4K video while simultaneously carrying low latency Command and Control data.

The interoperable Mesh Rider Radio platform is available in many frequency bands between 600 MHz and 6 GHz in Mini, OEM, Embedded, Wearable and External form factors. This flexibility allows customers to use their industry specific frequency bands for deploying private wireless networks that encompasses all the use cases for human and machine collaboration.

For more information, please visit: <https://doodlelabs.com/smart-radio/>

Key Features - Mesh Rider Radio Platform

PERFORMANCE RF

- Long range (field tested >100km) and high throughput (up to 100 Mbps) Mesh Rider waveform
- Interference resistant COFDM for robust link quality in difficult RF environments
- Exceptional Multipath and NrLOS MIMO performance
- Adaptive radio modulations from BPSK up to 64QAM, with fast per packet optimization to maximize link performance in dynamic environments
- Software defined channel bandwidth for efficient re-use of spectrum
- Convolutional coding, Forward Error Correction (FEC), ACK-retransmits, Maximal Ratio Combining, Spatial Multiplexing, and Space Time Block Coding for robust data transmission over noisy channel/spectrum
- Single channel, Time Division Duplexing (TDD) for bi-directional traffic
- Resistant to high-power jamming signals
- ATPC for widely dispersed mesh network
- Built-in Spectrum Scanner to help mitigate interference issues

PERFORMANCE NETWORKING

- Ultra-Reliable Low Latency Channel (URLLC) for Command and Control
- Optimized video streaming channel for Unicast and Multicast transport
- Self-healing/self-forming multi-frequency mobile mesh for highly reliable network with redundancy
- FIPS Certified AES 256- and 128-bit encryption
- End-to-end IP architecture with Ad Hoc, WDS transparent bridge, Client, AP, and Internet Gateway operating modes
- Embedded network management APIs

ADDITIONAL FEATURES

- Very small size, weight, and power for mobile applications
- Ethernet, USB, and UART interfaces to allow easy integration into different system architectures
- Leverage the benefits of the most extensible OpenWrt ecosystem and install 3rd party IoT applications
- Rugged, vibration resistant construction to meet MIL-specs
- MIL-spec temp range (-40C to +85C)
- High quality, manufactured in ISO 9001 and ISO 14001 certified facilities
- COTS - Commercial off the Shelf
- Extended lifespan and availability

System Integration

The Mesh Rider Radio has been designed to be plug and play. Only USB and a power supply are required for integration.

Visit [Doodle Labs Technical Library](#) for extensive design-in documents.

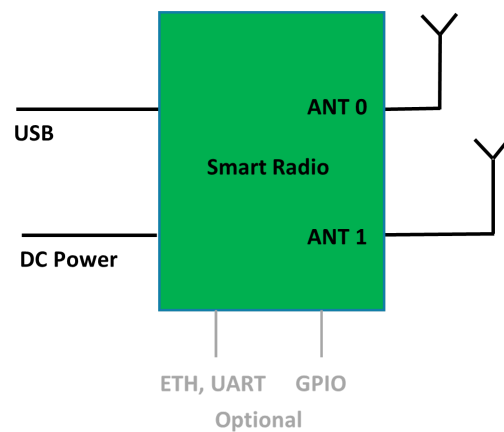

Technical Specifications (2400~2482 MHz, WiFi band)

Model Category	XTreme
ORDERING CODES	
Radio Configuration	2x2 MIMO
Model #	RM-5700-2LSX-SA-ST
Antenna (Optional)	ANT-5700-3-O
Evaluation Kit (Optional)	EK-5700-2L: 2x Multi-band Antenna, Breakout board, Cables
Design-In Documentation	Doodle Labs Technical Library
PERFORMANCE OVERVIEW	
Data Throughput at 10-meter range with Attached 3 dBi Antennas (Indicative)	80 Mbps (20 MHz Channel) 40 Mbps (10 MHz Channel) 20 Mbps (5 MHz Channel) 12 Mbps (3 MHz Channel)
Over the Air Data Encryption	128-bit AES (Full throughput) 256-bit AES (12 Mbps max throughput)
FIPS Certification (Optional)	FIPS 140-3
Operating Modes	Mesh, WDS AP, WDS Client Bridged or Internet Gateway with NAT
Command & Control channel	Ultra-Reliable Low Latency Channel (URLLC). Latency 1.5-10 ms
Video Channel	Optimized video streaming with Unicast and Multicast transmission
RF SPECIFICATIONS	

Protocol Compatibility	Fully compatible with Doodle Labs Mesh Rider Waveform
Frequency Range	5650-5755 MHz
Advanced Band Filters	Dedicated filters for high interference immunity
Max RF Power at SMA port (Software control) Each radio individually calibrated	1W (30 dBm) @ MCS 0,8 0.8W (29 dBm) @ MCS 3,11 0.4W (26 dBm) @ MCS 5,13 250mW (24 dBm) @MCS 7,15
Channel Sizes (Software Selectable)	3, 5, 10, 20 MHz
Radio Data Rate	Auto adapting Modulation Coding Scheme (MCS0-15)
Antenna Signal Strength	-30 to -90 dBm (Recommended), Absolute Maximum= +12 dBm
Receiver LNA Gain	15 dB
RF Power Control	In 1 dBm steps, Tolerance ± 1 dBm
Automatic Transmit Power Control (ATPC)	Intelligently adjusts the transmit power for very close range operation
Integrated Antenna Port Protection	Able to withstand open port, >10 KV (contact) and >15KV (open air discharge) as per IEC-61000-4-2
Wireless Error Correction	FEC, ARQ
Receive Noise Figure	+4 dB
Receive Adjacent Channel Rejection (ACRR)	34 dB @ MCS0 for 20 MHz channel (Typ)
Transmitter Adjacent Channel Leakage Ratio (ACLR)	< 28 dB _r ($F_c \pm ChBW$)

Transmitter Spurious Emission Suppression	< 40 dBc
Frequency Accuracy	±10 ppm max over life
NETWORKING SPECIFICATIONS	
Mesh Router	Self-Forming/Self-Healing, Peer to Peer
Custom Software Package Manager	Image Builder, OPKG, ipk
Radio Management	Web GUI (HTTPs), SSH and JSON-RPC
Access control	Password, MAC, IP, Port filtering
Supported Protocols	IPv6, QoS, DNS, HTTPS, IP, ICMP, NTP, DHCP
Software Upgrade	Over the air software upgrade supported
HARDWARE SPECIFICATIONS	
Power Input	5V ± 5%
DC Power Consumption	TX Continuous 16W (27 dBm), TX Continuous 11W (24 dBm), 4.1W Rx mode
Dimensions	Baseband: 47 x 28 x 5 mm RF Board: 46 x 51 x 6.5 mm 36.5 grams
Mesh Rider Antenna Ports	2x MMCX-Female connector
Host Interface	Ethernet (100 Base-T), USB -Dev, 1x UART (3.3V)
Temperature range (Operating)	Industrial: -40°C to +85°C <i>* System's thermal design should ensure that the radio's case temperature is maintained within these specifications.</i>
Temperature range (Non-Operating)	-40°C to +100°C

Ingress Protection	IP 50, Dust Protected, No Liquid protection
Relative Humidity	5% to 95% non-condensing
Shock and Vibration Resistance	Compliant to MIL-STD-810H for high shock and vibration
Reliability	Extreme Reliability, IPC Class 2 standard with Class 3 options
Integrated CPU	MIPS 24Kc, 540 MHz, 32MB Flash, 64MB DDR2 RAM
ESD Protection	IEC 61000-4-2 test criteria, Level 3 (± 6 KV) for Contact Discharge and Level 4 (± 15 KV) for Air Discharge
MTBF	>235k hours (25 years)
Life Cycle Planning	Extended lifespan with 7 years guaranteed availability
REGULATORY INFORMATION	
Japan (MIC)	Certified under Article 2-1-72 Unmanned Mobile Image Transmission System
Regulatory Requirements	Designed and verified to meet various regulatory requirements. Formal testing and approval are required for the Integrator's antenna type. The Integrator is responsible for obtaining all regulatory approvals in target markets for the finished product.
RoHS/WEEE Compliance	Yes. 100% Recyclable/Biodegradable packaging
EXPORT INFORMATION	
ECCN Code	5A992
HS Code	85256010

ADDITIONAL RF SPECIFICATIONS

MCS Rate	Modulation	Combined Output Power (dBm)	Sensitivity (dBm)	UDP Throughput (Mbps)
0	BPSK (1/2)	30	-90	5.4
1	QPSK (1/2)	29	-88	10.62
2	QPSK (3/4)	29	-86	15.66
3	16-QAM (1/2)	29	-84	20.52
4	16-QAM (3/4)	28	-80	29.88
5	64-QAM (2/3)	27	-76	38.88
6	64-QAM (3/4)	26	-74	43.11
7	64-QAM (5/6)	24	-72	47.34
8	BPSK (1/2)	30	-87	10.53
9	QPSK (1/2)	29	-85	20.43
10	QPSK (3/4)	29	-83	29.7
11	16-QAM (1/2)	29	-81	38.52
12	16-QAM (3/4)	28	-77	54.72
13	64-QAM (2/3)	27	-73	69.3
14	64-QAM (3/4)	26	-71	76.14
15	64-QAM (5/6)	24	-69	82.8

Note 1: Performance based on 20-MHz bandwidth

Note 2: Sensitivity and throughput are approximately proportional to bandwidth.

X-ON Electronics

Largest Supplier of Electrical and Electronic Components

Click to view similar products for [Ethernet Development Tools](#) category:

Click to view products by [Doodle Labs](#) manufacturer:

Other Similar products are found below :

[KSZ8081RNB-EVAL](#) [EV06P90A](#) [GSW145-EVK-1](#) [GPY215-EVK-1](#) [EVB9512](#) [KSZ8041NL-EVAL](#) [KSZ8851SNL-EVAL](#) [KSZ8999-EVAL](#)
[WIZ550S2E-232-EVB](#) [EVB-MEC1428MECC](#) [MIKROE-2796](#) [3201](#) [KIT-14547](#) [OM14500/TJA1102JP](#) [DFR0125](#) [UKIT-006GP](#) [UKIT-003FE](#) [UKIT-002GB](#) [UKIT-001FE](#) [EVB-KSZ9477](#) [OM-E-ETH](#) [3785](#) [A000024](#) [ASX00006](#) [ASX00021](#) [ASX00026](#) [PE-405](#) [G650-07975-01](#)
[76002138](#) [XKRR-Z8S-WZM](#) [EK-1700-21N3](#) [EK-1700-22M3](#) [EK-5700-2L](#) [ESP32-ETHERNET-KIT-VE](#) [EVB-KSZ9897-1](#) [SGMII-PEX-RISER](#) [KITA2GTC377SECGTWTBO1](#) [MICRO125-KIT](#) [U138](#) [MXL86110I-EVK-1](#) [KSZ9031RNX-EVAL](#) [AC164121](#) [AC164123](#)
[AC164132](#) [AC320004-5](#) [AC320004-6](#) [AC320004-7](#) [DM320114](#) [DM990004](#) [EV02N47A](#)