

Features

- Ideal for printed circuit board mounting
- The plastic material used carries Underwriters Laboratory flammability recognition 94V-0
- Built-in printed circuit board stand-offs
- High case dielectric strength
- High temperature soldering guaranteed 260 C/5 seconds at 5 lbs (2.3kg) tension

Mechanical Data

- Case: Reliable low cost construction utilizing molded plastic technique
- Terminals: Plated leads solderable per MIL-STD-202, Method 208
- Mounting Position: Any

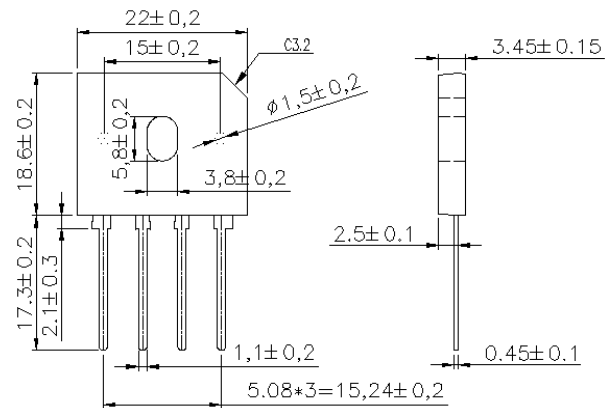

Dimensions in inches and (millimeters)

Maximum Ratings & Thermal Characteristics

Parameter	Symbol	GBU8005	GBU801	GBU802	GBU804	GBU806	GBU808	GBU810	Unit
Maximum repetitive peak reverse voltage	V_{RRM}	50	100	200	400	600	800	1000	V
Maximum RMS bridge input voltage	V_{RMS}	35	70	140	280	420	560	700	V
Maximum DC blocking voltage	V_{DC}	50	100	200	400	600	800	1000	V
Maximum average forward rectified output current at $T_C=100^\circ\text{C}$ (with heatsink)	$I_{F(AV)}$	8.0							A
Peak forward surge current single sine-wave superimposed on rated load (JEDEC Method)	I_{FSM}	175							A
Rating for fusing ($t < 8.3\text{ms}$)	I^2t	127							A^2sec
Operating junction and storage temperature range	T_J T_{STG}	-55 to + 150							$^\circ\text{C}$

Notes: Rating at 25 C ambient temperature unless otherwise specified, Resistive or Inductive load, 60 Hz. For Capacitive load derate current by 20%.

Electrical Characteristics

Parameter	Symbol	GBU8005	GBU801	GBU802	GBU804	GBU806	GBU808	GBU810	Unit
Maximum instantaneous forward voltage drop per leg at 4.0A	V_F	1.1							V
Maximum DC reverse current at rated DC blocking voltage per element	I_R	10 500							μA

Notes: Rating at 25 C ambient temperature unless otherwise specified, Resistive or Inductive load, 60 Hz. For Capacitive load derate current by 20%. Thermal resistance from Junction to Ambient on P.C.board mounting.



■ Rating and Characteristic Curves (TA=25°C Unless otherwise noted)

Fig. 1 Derating Curve for Output Rectified Current

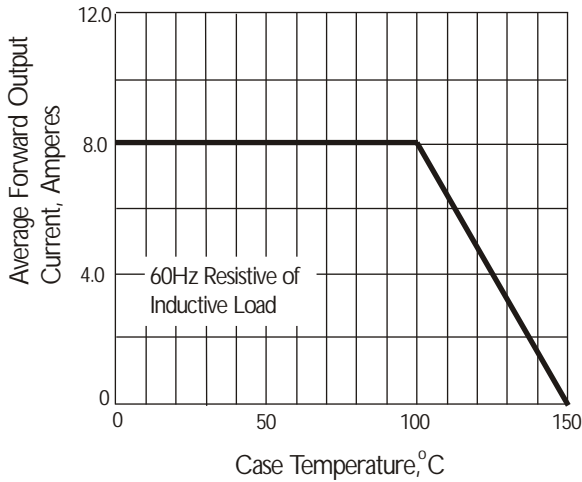

Fig. 2 Maximum Non-repetitive Peak Forward Surge Current

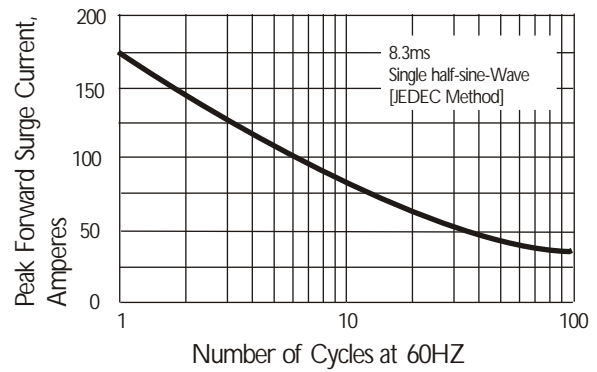

Fig. 3 Typical Instantaneous Forward Characteristics

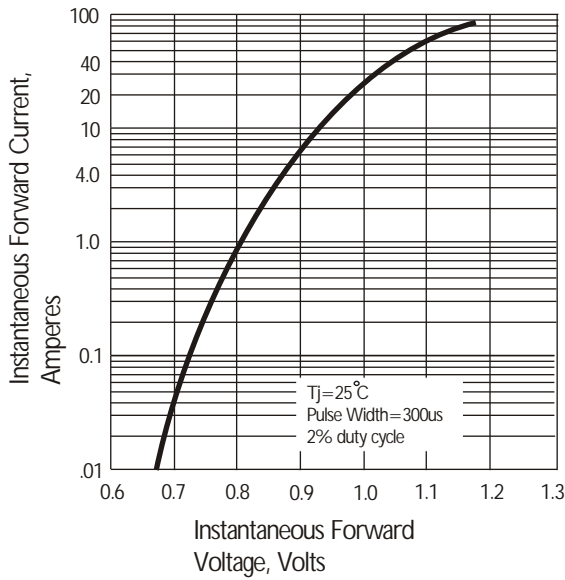

Fig. 4 Typical Reverse Characteristics

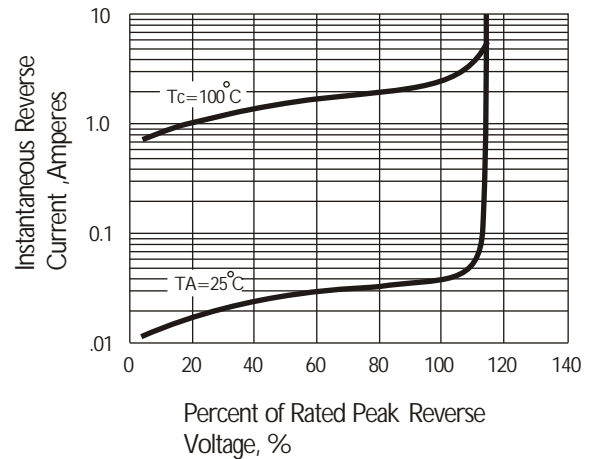
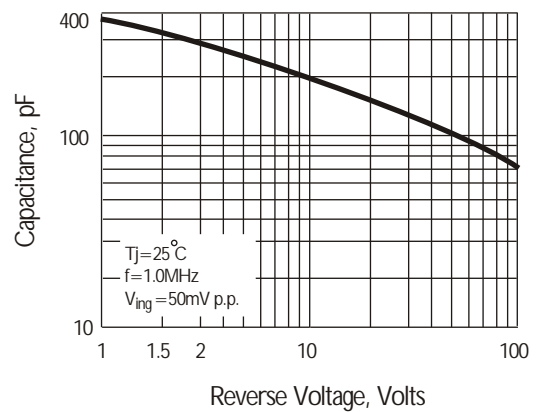

Fig. 5 Typical Junction Capacitance



X-ON Electronics

Largest Supplier of Electrical and Electronic Components

Click to view similar products for [Bridge Rectifiers](#) category:

Click to view products by [DOWO](#) manufacturer:

Other Similar products are found below :

[MB252](#) [MB356G](#) [MB358G](#) [GBJ1504-BP](#) [GBU10B-BP](#) [GBU15K-BP](#) [GBU4A-BP](#) [GBU4D-BP](#) [DB101-BP](#) [DF01](#) [DF10SA-E345](#) [KBPC50-10S](#) [RS405GL-BP](#) [GBJ1502-BP](#) [GBU6M](#) [TB102M](#) [MB1510](#) [MB86](#) [TL401G](#) [MDA920A2](#) [TU602](#) [TU810](#) [MP5010W-BP](#) [MP501W-BP](#) [MP502-BP](#) [KBPC25-02](#) [VBO160-12NO7](#) [VS-110MT120KPBF](#) [VS-60MT80KPBF](#) [DB105-BP](#) [DF1510S](#) [VS-40MT160PAPBF](#) [GBU4G-BP](#) [GSIB15A80-E3/45](#) [DB104-BP](#) [D3SB60](#) [TB354](#) [GBJ2504-BP](#) [26MB100A](#) [B1S-G](#) [VS-40MT160KPBF](#) [VUO162-16NO7](#) [ABS10-G](#) [GBU6B-BP](#) [GBJ1508-BP](#) [BR5010-G](#) [ABS6-G](#) [B125C800G-E4/51](#) [MSB15MH-13](#) [LBS10-13](#)