

Description

LMV321 (single channel) is a rail-to-rail input, output voltage feedback, low power consumption operational amplifier. It has wide input common mode voltage and output swing. The minimum working voltage can be up to 2.1V, and the maximum working voltage is recommended to be 5.5V. Used as power amplifier in all kinds of pocket or portable stereo radio recorders.

LMV321 has the following characteristics: Can provide 1MHz gain bandwidth product. It has an extremely low input bias current (about 10pA level) and can be used for integration, photo diode amplifiers and piezoelectric sensors. The Rail to Rail input and output buffers are also used for specific IC designs in single power systems. Applications of this series of amplifiers include safety monitoring, portable devices, batteries and power supplies, supply control, signal processing and interfaces in low power sensor systems.

Features

- Rail to rail input and output, typical 0.8mv Vos
- Gain bandwidth product 1MHz
- Low input bias current: 10pA Level, <1nA
- Low Power consumption
- 2.1V ~ 5.5V working voltage
- Low operating current: 60uA

Applications

- ASIC input and output amplifier
- Sensor interface
- Piezoelectric sensing amplifier
- Battery-powered equipment
- The mobile communication
- Audio output

SOT-23-5

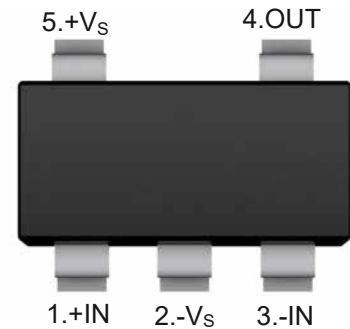

Pin arrangement diagram

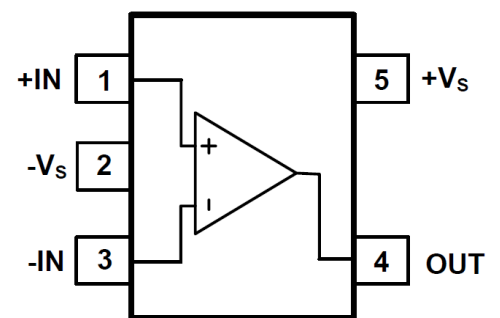

Absolute Maximum Ratings ($T_A=25^\circ\text{C}$) ^{Note1}

Parameter	Symbol	Value	Units
Supply Voltage	V_{CC}	7.5	V
Common-mode Input Voltage	V_{ICR}	$(-V_S)-0.5\sim(+V_S)+0.5$	V
Junction Temperature	T_J	150	$^\circ\text{C}$
Operating Temperature Range	T_{OPR}	0~70	$^\circ\text{C}$
Lead Temperature (Soldering, 10 sec)	T_L	250	$^\circ\text{C}$
Storage Temperature Range	T_{STG}	-50~150	$^\circ\text{C}$

Note1: Exceeding the above limits may damage to the chip. The reliability of the device will also be affected if the device works under the limit conditions. Electrostatic discharge can also cause damage to chips, so it is suggested to take some preventive measures for integrated circuits. Failure to follow proper handling and installation can also cause damage. Precision LMV321 and other devices are more vulnerable to damage than ordinary devices in the case of tiny electrostatic, and small parameter changes may make the whole circuit performance substandard.

Electrical Characteristics

At $R_L = 100\text{k}\Omega$ connected to $V_S/2$, and $V_{OUT} = V_S/2$, $T_A=25^\circ\text{C}$), unless otherwise noted.

Parameter	Symbol	Conditions	Min.	Typ.	Max.	Units
Input Offset Voltage	V_{OS}		--	± 0.8	± 5	mV
Input offset current	I_{OS}		--	10	--	pA
Input bias current	I_B		--	10	--	pA
Common-mode input voltage range	V_{CM}	$V_S=5.5\text{V}$	--	-0.1~5.6	--	V
Open-loop Gain	AOL	$V_O=0.1\text{V}\sim 4.9\text{V}$, $R_L=5\text{k}\Omega$	70	80	--	dB
		$V_O=0.035\text{V}\sim 4.96\text{V}$, $R_L=100\text{k}\Omega$	80	84	--	
Common Mode Rejection	CMRR	$V_{CM}=-0.1\text{V}\sim 4\text{V}$, $V_S=5.5\text{V}$	62	70	--	dB
		$V_{CM}=-0.1\text{V}\sim 5.6\text{V}$, $V_S=5.5\text{V}$	56	68	--	
Power Supply Rejection	PSRR	$V_{CM} = (-V_S)+0.5\text{V}$, $V_S=2.5\text{V}\sim 5.5\text{V}$	60	80	--	dB
Input offset voltage drift	$\Delta V_{OS}/\Delta T$		--	2.7	--	$\mu\text{V}/^\circ\text{C}$
Input voltage swing	V_I	$R_L=100\text{k}\Omega$	--	0.008	--	V
		$R_L=10\text{k}\Omega$	--	0.08	--	V
Operating voltage range	V_W		2.1	--	5.5	mV
Output Current	I_O		20	23	--	mA
Quiescent Current	I_Q	$I_{OUT}=0$	--	60	80	μA
Slew Rate	SR	$G = +1$, 2V Output Step	--	0.52	--	$\text{V}/\mu\text{s}$
Gain Bandwidth Product	GBP	$C_L = 100\text{pF}$	--	1	--	MHz
Equivalent Input Noise Voltage	eN	$f=1\text{KHz}$	--	27	--	$\text{nV}/\sqrt{\text{Hz}}$
		$f=10\text{KHz}$	--	20	--	

Typical Applications

1. differential amplifier

As shown in the figure, if the resistance is equal, ($R_4 / R_3 = R_2 / R_1$), then the output $V_{OUT} = (V_p - V_n) \times R_2 / R_1 + V_{REF}$

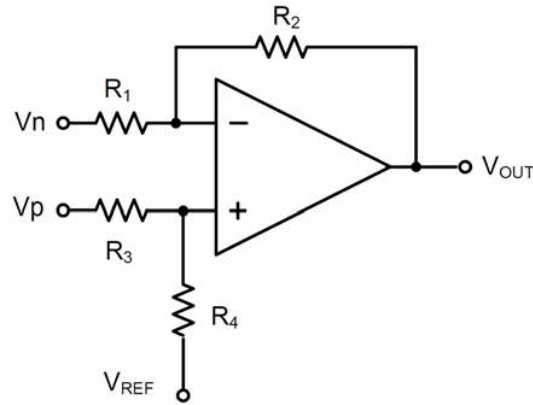

2. instrumentation amplifier

The circuit in the figure above performs the same function, but the input is high impedance.

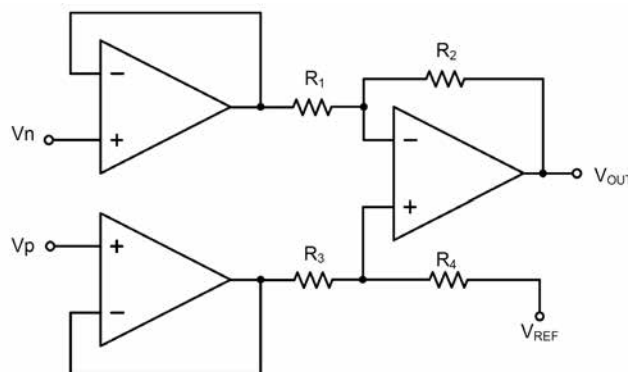

3. Low pass active filtering

The low-pass filter circuit shown here has a $(-R_2 / R_1)$ DC gain and -3db at a frequency of $1/2 \text{ PI R2C}$ corner. Make sure the filter is within the amplifier's bandwidth. Large feedback resistors are easily accompanied by parasitic capacitance at high speed, resulting in adverse effects such as oscillation. Keep the resistance value as low as possible and consider the appropriate output load.

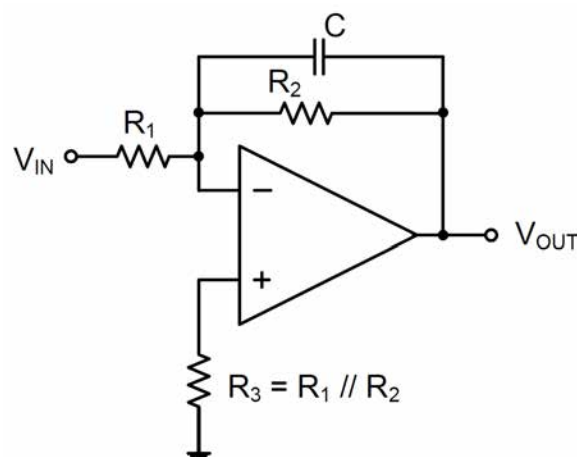



Typical characteristic curve

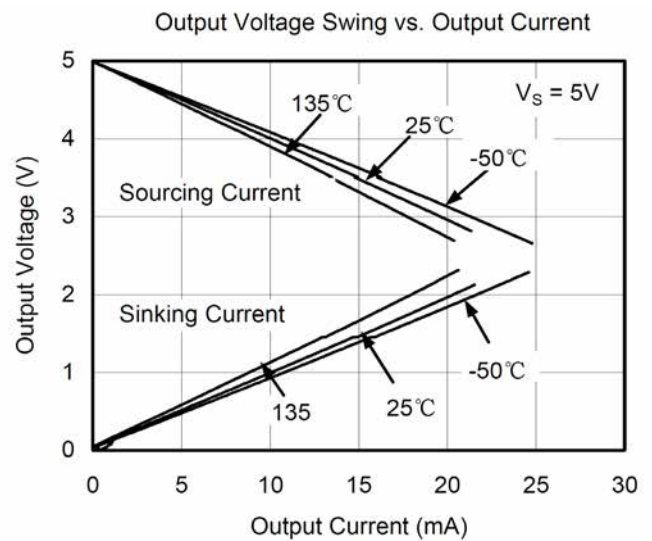
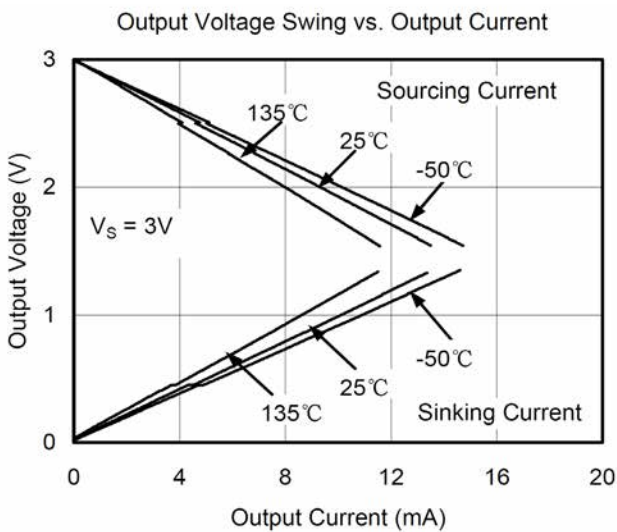
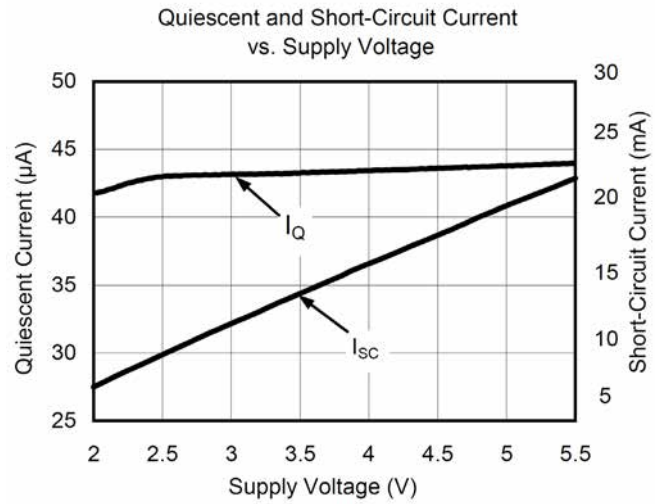
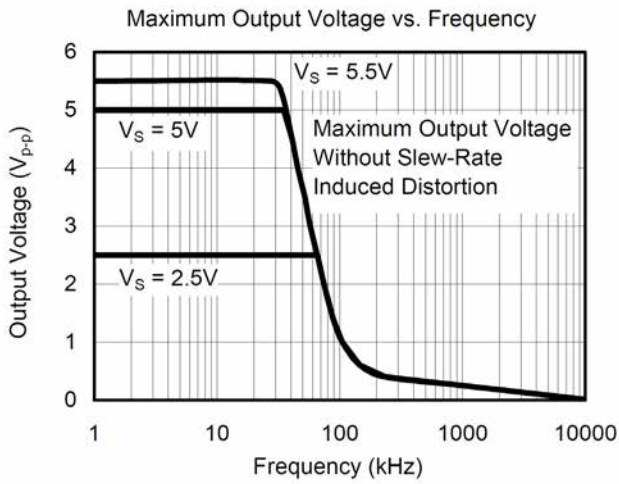
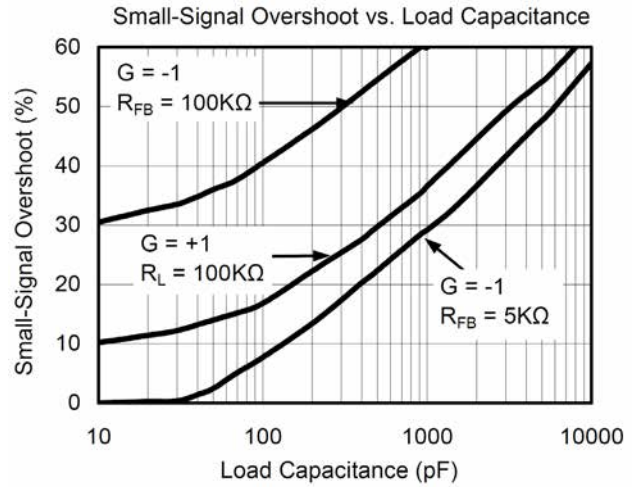
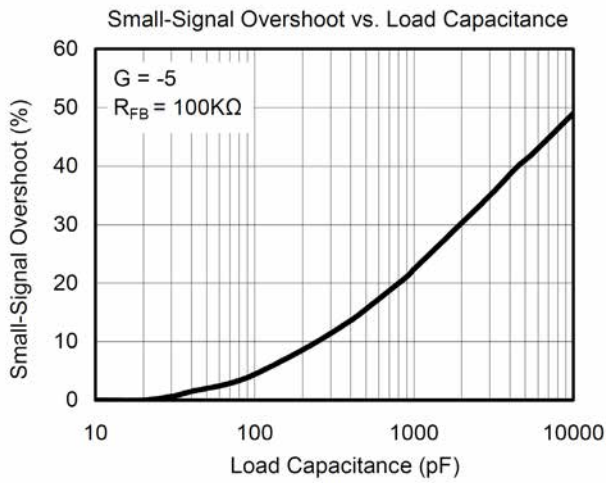

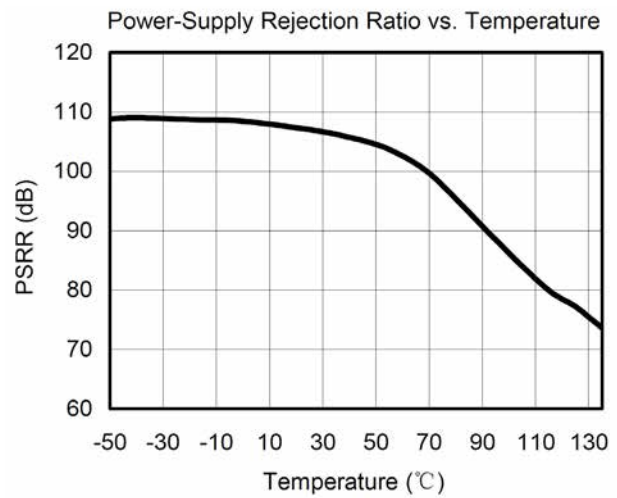
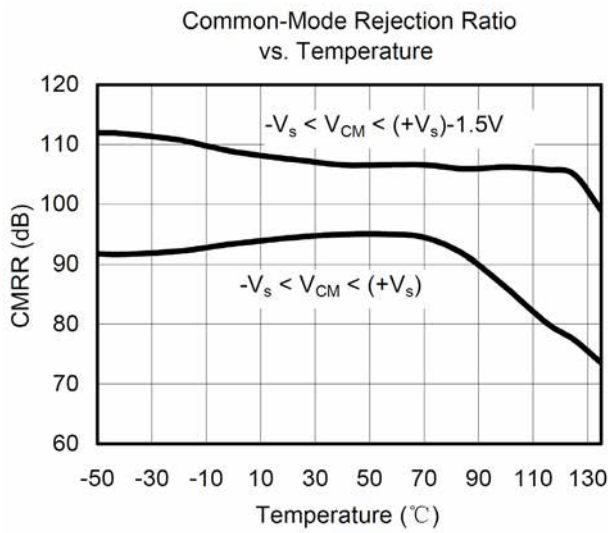
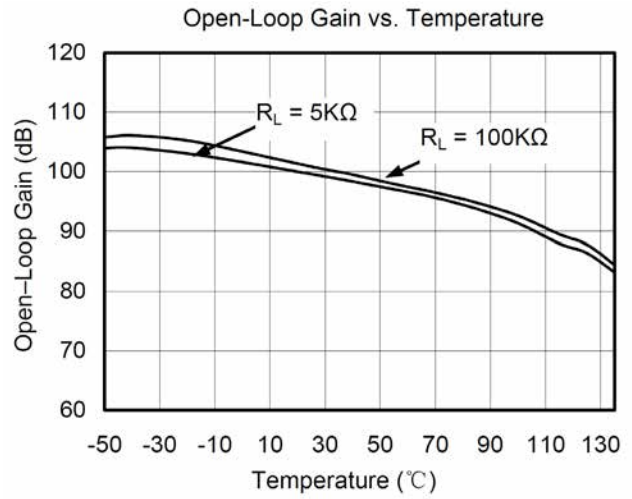
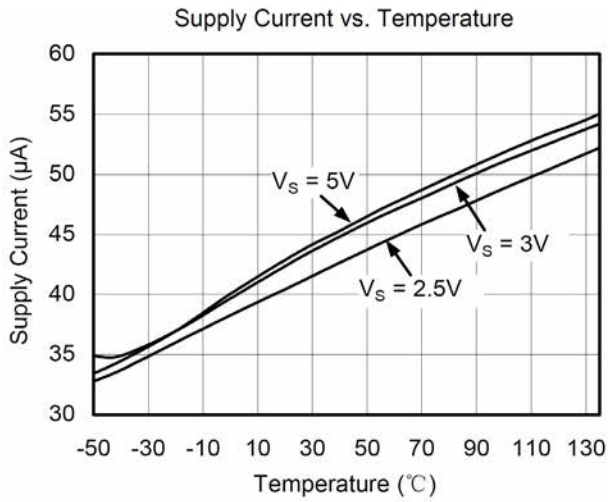



Package Outline

SOT-23-5

Dimensions in mm

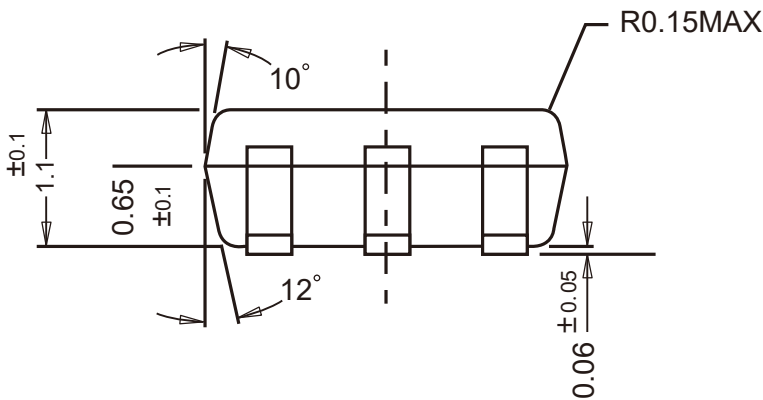
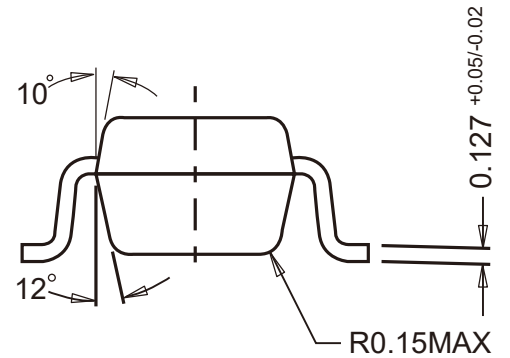
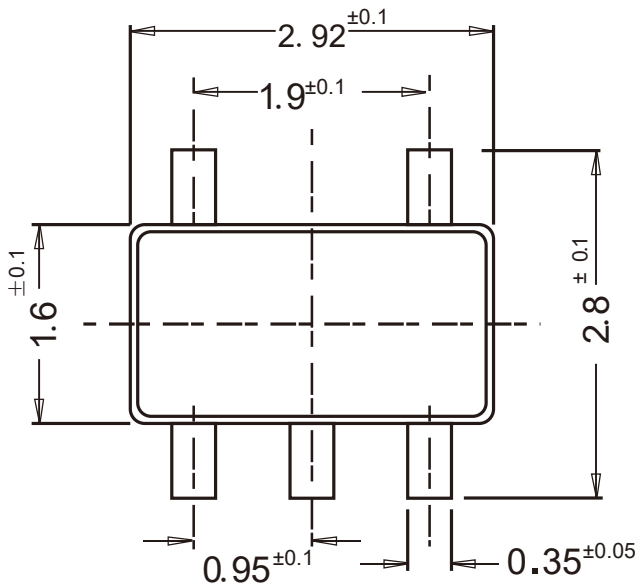

Ordering Information

Device	Package	Shipping
LMV321	SOT-23-5	3,000PCS/Reel&7inches

X-ON Electronics

Largest Supplier of Electrical and Electronic Components

Click to view similar products for [Operational Amplifiers - Op Amps](#) category:

Click to view products by [DOWO](#) manufacturer:

Other Similar products are found below :

[430227FB](#) [UPC451G2-A](#) [UPC824G2-A](#) [LT1678IS8](#) [UPC258G2-A](#) [NCV33202DMR2G](#) [NJM324E](#) [M38510/13101BPA](#) [NTE925](#)
[AZV358MTR-G1](#) [AP4310AUMTR-AG1](#) [AZV358MMTR-G1](#) [SCY33178DR2G](#) [NCV5652MUTWG](#) [NCV20034DR2G](#) [NTE778S](#) [NTE871](#)
[NTE937](#) [MCP6V16UT-E/OT](#) [SCY6358ADR2G](#) [UPC4570G2-E1-A](#) [NCS20282FCTTAG](#) [UPC834G2-E1-A](#) [UPC1458G2-E2-A](#) [UPC813G2-](#)
[E2-A](#) [UPC458G2-E1-A](#) [UPC824G2-E2-A](#) [UPC4574G2-E2-A](#) [UPC4558G2-E2-A](#) [UPC4560G2-E1-A](#) [UPC258G2-E1-A](#) [UPC4742GR-9LG-](#)
[E1-A](#) [UPC4742G2-E1-A](#) [UPC832G2-E2-A](#) [UPC842G2-E1-A](#) [UPC802G2-E1-A](#) [UPC4741G2-E2-A](#) [UPC4572G2-E2-A](#) [UPC844GR-9LG-](#)
[E2-A](#) [UPC259G2-E1-A](#) [UPC4741G2-E1-A](#) [UPC4558G2-E1-A](#) [UPC1251GR-9LG-E1-A](#) [UPC4744G2-E1-A](#) [UPC4092G2-E1-A](#)
[UPC4574G2-E1-A](#) [UPC4062G2-E2-A](#) [UPC451G2-E2-A](#) [UPC832G2-E1-A](#) [UPC844GR-9LG-E1-A](#)