

PESDxxxL2BT

1. Description

The PESDxxxL2BT is a Transient Voltage Suppressor Arrays that designed to protect components which are connected to data and transmission lines against electrostatic discharge (ESD), electrical fast Transients (EFT), and lightning. All pins are rated to withstand 15kV ESD pulses using the IEC61000-4-2 are discharge method.

2. Features

- IEC 61000-4-2 Level 4 ESD Protection
 - ±15kV Contact Discharge
 - ±15kV Air Discharge
- 450W Peak pulse Power (8/20us)
- Low clamping voltage
- Protects two bidirectional or two Unidirectional lines
- Low leakage current
- RoHS compliant

3. Applications

- Portable electronic
- Control & monitoring systems
- Servers, notebooks, and desktop PCs
- Set-top box
- Communications systems
- Cellular handsets and accessories

4. Ordering Information

Part Number	Package	Material	Packing	Quantity per reel	Flammability Rating	Reel Size		
PESDxxxL2BT	SOT-23	Halogen free	Tape & Reel	3,000 PCS	UL 94V-0	7 inches		
Marking for the PESDxxxL2BT series								
V_{RWM}	3.3V	5V	8V	12V	15V	18V	24V	36V
Marking	C03	C05	C08	C12	C15	C18	C24	C36

Table-1 Ordering information

5. Pin Configuration and Functions

Pin	Name	Description	Outline	Circuit Diagram
1	IO	Connect to IO		
2	IO	Connect to IO		
3	GND	Connect to GND		

Table-2 Pin configuration

6. Specification

6.1. Absolute Maximum rating

Over operating free-air temperature range (unless otherwise noted)

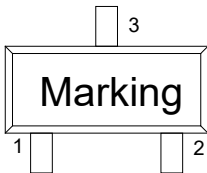
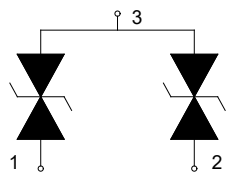
Parameters	Symbol	Min.	Max.	Unit
Peak pulse power (tp=8/20us)@25°C	P _{pk}	-	450	W
Peak pulse current (tp=8/20us)@25°C	I _{PP}		Refer to Table-5	A
ESD (IEC61000-4-2 air discharge) @25°C	V _{ESD}	-	±15	kV
ESD (IEC61000-4-2 contact discharge) @25°C	V _{ESD}	-	±15	kV
Junction temperature	T _J	-	125	°C
Operating temperature	T _{OP}	-40	85	°C
Storage temperature	T _{STG}	-55	150	°C
Lead temperature	T _L	-	260	°C

Table-3 Absolute Maximum rating

6.2. Electrical Characteristics

Symbol	Description
V_{RWM}	Rated reverse stand-off voltage
V_{BR}	Minimum breakdown voltage @ $I_T = 1mA$
V_{CL}	Typical Clamping voltage
I_{PP}	Maximum peak pulse current
I_R	Reverse leakage current @ V_{RWM}
C_O	Typical line capacitance ($V_{IO}=0V$, $V_{P-P} = 30mV$, $f = 1MHz$)

Table-4 Parameters Description

At $T_A = 25^\circ C$ unless otherwise noted

Part Number	V_{RWM}	V_{BR}	$V_{CL}@I=1A$	I_{PP}	$V_{CL}@I=I_{PP}$	I_R	C_O
	(V)	(V)	(V)	(A)	(V)	(μA)	(pF)
PESD3V3L2BT	3.3	4.5	8.5	24	22.0	1.0	120
PESD5V0L2BT	5	6.5	9.5	20	22.0	1.0	120
PESD8V0L2BT	8	8.5	11.0	15	28.0	1.0	110
PESD12VL2BT	12	13.3	20.0	12	37.0	1.0	70
PESD15VL2BT	15	16.5	25.0	9.0	55.0	1.0	40
PESD18VL2BT	18	19.5	30.0	7.0	56.0	1.0	35
PESD24VL2BT	24	26.0	40.0	6.0	63.0	1.0	30
PESD36VL2BT	36	38	55.0	4.0	72.0	1.0	25

Table-5 Electrical Characteristics for All Series



7. Typical Characteristic

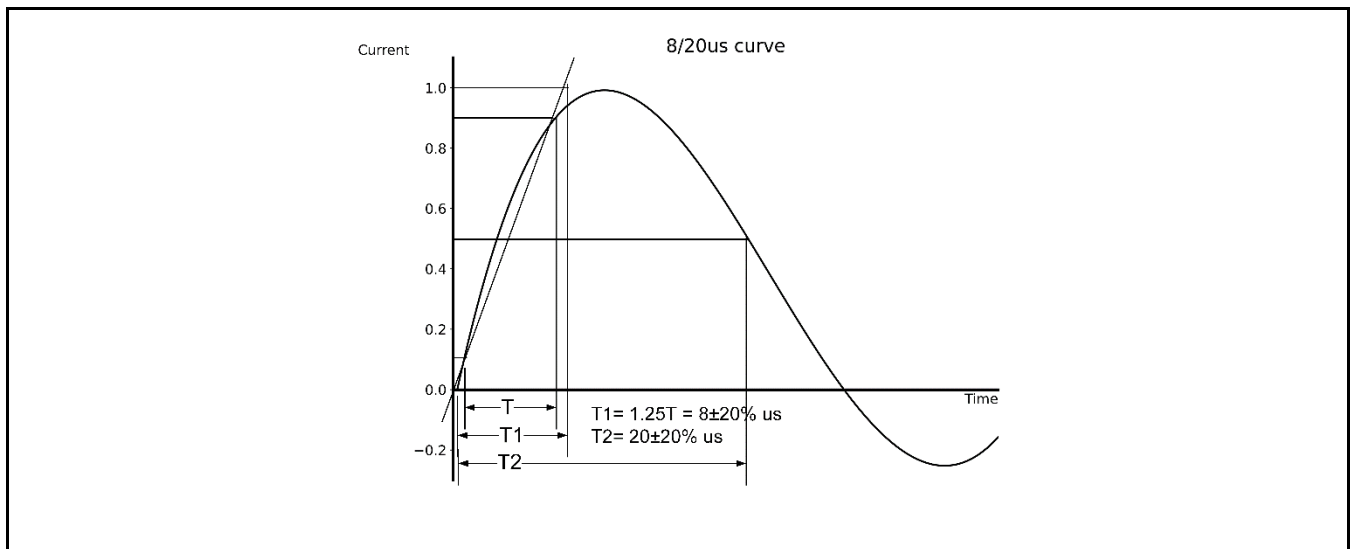

8. Typical Application

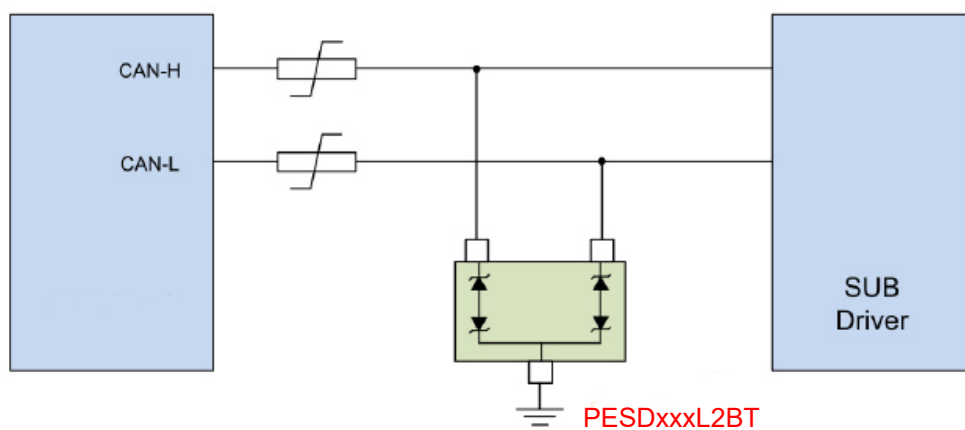

Typical Interface Application



9. Dimension

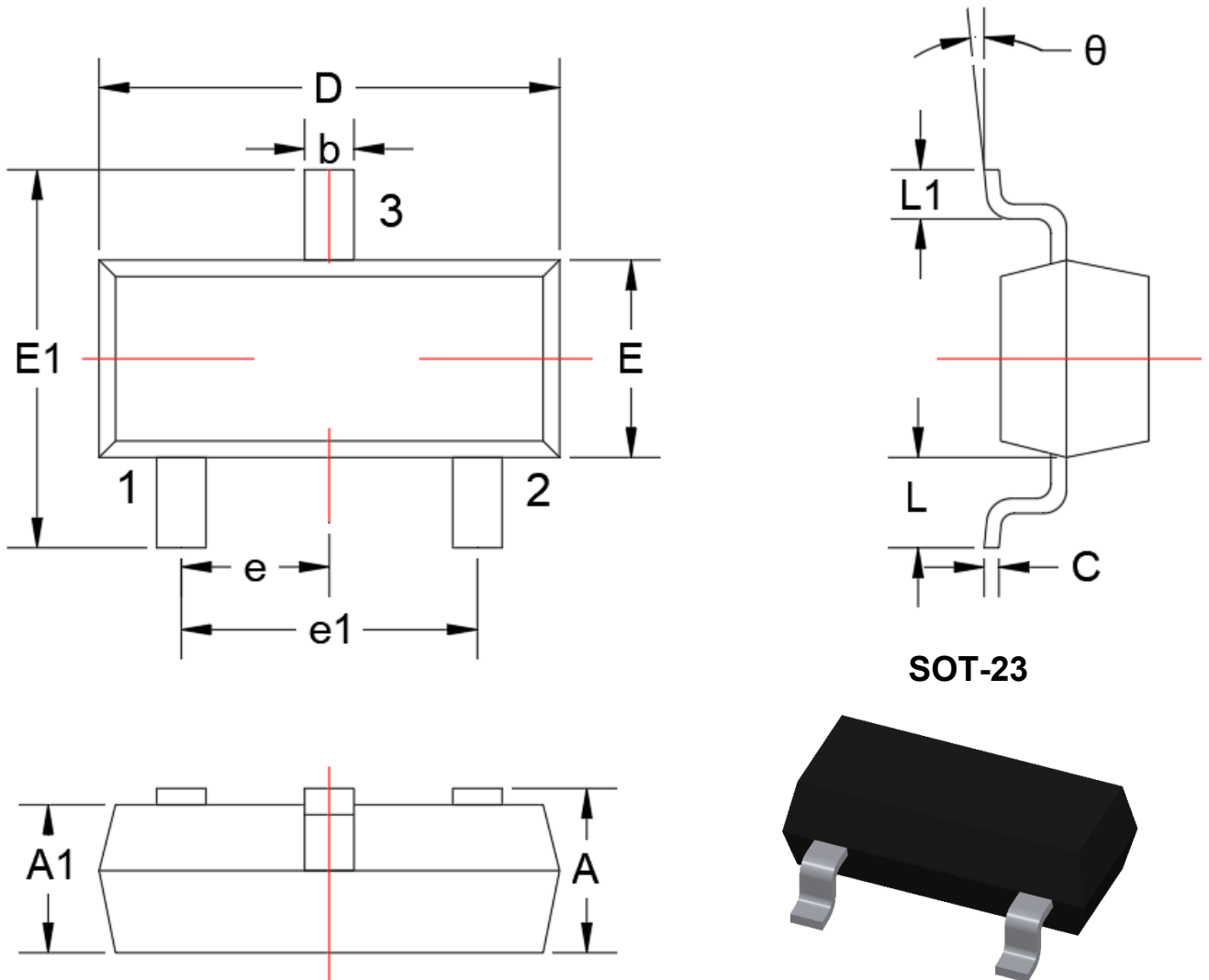

SOT-23

Dimensions in Millimeters					
Symbol	Min.	Max.	Symbol	Min.	Max.
A	0.9	1.15	e1	1.80	2.00
A1	0.90	1.05	L	0.55REF	
b	0.30	0.50	L1	0.30	0.50
C	0.08	0.15	θ	0°	8°
D	2.80	3.00			
E	1.20	1.40			
E1	2.25	2.55			
e	0.95TYP				

Table-5 Product dimensions



10. Recommended Land Pattern

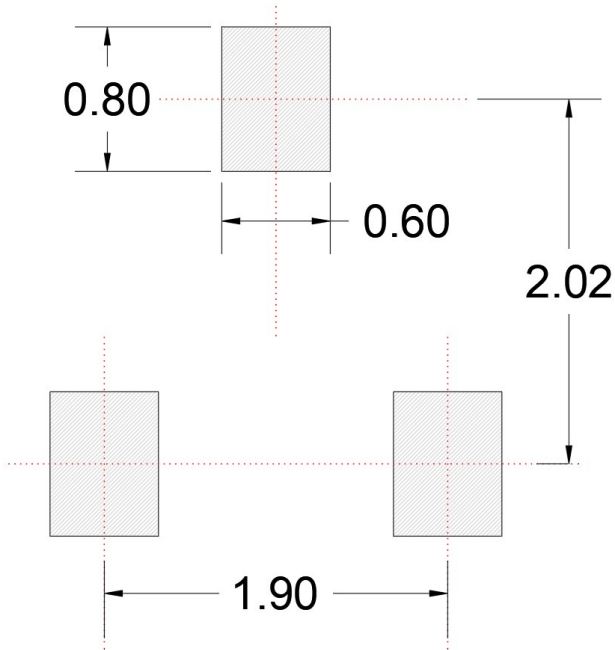

Note:

1. Controlling dimension: in millimeters
2. General tolerance: $\pm 0.05\text{mm}$
3. The pad layout is for reference only

X-ON Electronics

Largest Supplier of Electrical and Electronic Components

Click to view similar products for [ESD Suppressors / TVS Diodes](#) category:

Click to view products by [DOWO](#) manufacturer:

Other Similar products are found below :

[60KS200C](#) [D18V0L1B2LP-7B](#) [D5V0F4U5P5-7](#) [NTE4902](#) [P4KE27CA](#) [P6KE11CA](#) [P6KE39CA-TP](#) [P6KE8.2A](#) [JANTX1N6053A](#)
[SA110CA](#) [SA60CA](#) [SA64CA](#) [SMBJ12CATR](#) [SMBJ33CATR](#) [SMBJ8.0A](#) [ESD105-B1-02EL E6327](#) [ESD112-B1-02EL E6327](#)
[ESD119B1W01005E6327XTSA1](#) [ESD5V0L1B02VH6327XTSA1](#) [ESD7451N2T5G](#) [19180-510](#) [CPDT-5V0USP-HF](#) [3.0SMCJ33CA-F](#)
[3.0SMCJ36A-F](#) [HSPC16701B02TP](#) [JANTX1N6126A](#) [JANTX1N6462](#) [JANTX1N6465](#) [USB50805e3/TR7](#) [D3V3Q1B2DLP3-7](#)
[D55V0M1B2WS-7](#) [DRTR5V0U4SL-7](#) [SCM1293A-04SO](#) [ESD200-B1-CSP0201 E6327](#) [SM12-7](#) [SM1605E3/TR13](#) [SMLJ45CA-TP](#) [CEN955](#)
[W/DATA](#) [82350120560](#) [VESD12A1A-HD1-GS08](#) [CPDUR5V0R-HF](#) [CPDQC5V0U-HF](#) [CPDQC5V0USP-HF](#) [CPDQC5V0-HF](#) [D1213A-](#)
[01LP4-7B](#) [ESD101-B1-02EL E6327](#) [824500181](#) [MMAD1108/TR13](#) [5KP100A](#) [5KP15A](#)