

Features

- 100Watts Peak Power per Line ($t_p = 8/20\mu s$)
- Protects two I/O lines
- Low operating voltage: 5V
- Ultra Low capacitance($<1.0pF$) for high-speed interfaces
- Solid-state technology

IEC COMPATIBILITY (EN61000-4)

- IEC 61000-4-2 (ESD) $\pm 15kV$ (air), $\pm 8kV$ (contact)
- IEC 61000-4-4 (EFT) 40A (5/50ns)
- IEC 61000-4-5 (Lightning) 6.5A (8/20 μs)

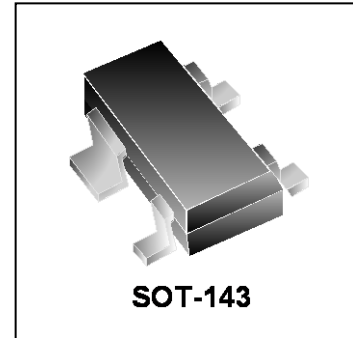

Mechanical Characteristics

- JEDEC SOT-143 package
- Molding compound flammability rating: UL 94V-0
- Marking : Making Code
- Packaging : Tape and Reel per EIA 481
- RoHS Compliant

Applications

- FireWire & USB
- Sensitive Analog Inputs
- Portable Electronics
- LAN/WAN equipment
- Video Line Protection
- Microcontroller Input Protection

Circuit Diagram

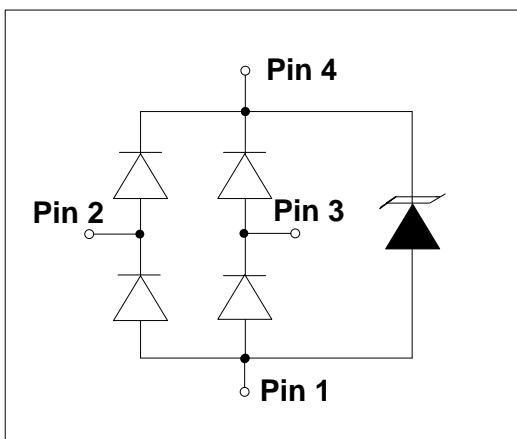

Schematic & PIN Configuration

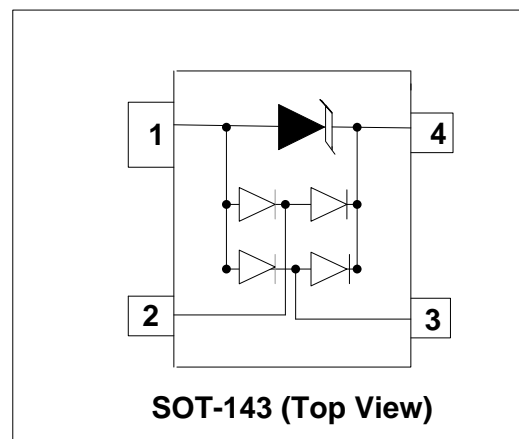

Absolute Maximum Rating			
Rating	Symbol	Value	Units
Peak Pulse Power ($t_p=8/20\mu s$)	P_{PP}	100	Watts
Peak Pulse Current ($t_p=8/20\mu s$)	I_{PP}	6.5	A
Lead Soldering Temperature	T_L	260(10sec)	$^{\circ}C$
Operating Temperature	T_J	-55 to + 125	$^{\circ}C$
Storage Temperature	T_{STG}	-55 to +150	$^{\circ}C$

Electrical Parameters (T=25°C)

Symbol	Parameter
I_{PP}	Maximum Reverse Peak Pulse Current
V_C	Clamping Voltage @ I_{PP}
V_{RWM}	Working Peak Reverse Voltage
I_R	Maximum Reverse Leakage Current @ V_{RWM}
V_{BR}	Breakdown Voltage @ I_T

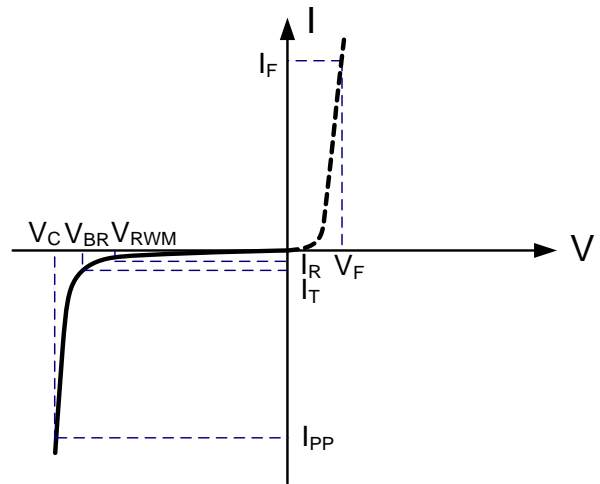

Electrical Characteristics

PRTR5V0U2X-N						
Parameter	Symbol	Conditions	Minimum	Typical	Maximum	Units
Reverse Stand-Off Voltage	V_{RWM}				5.0	V
Breakdown Voltage	V_{BR}	$I_T=1mA$	6.0			V
Reverse Leakage Current	I_R	$V_{RWM}=5V, T=25^{\circ}C$			1.0	μA
Clamping Voltage	V_C	$I_{PP}=1A, t_p=8/20\mu s$		10		V
Clamping Voltage	V_C	$I_{PP}=6.5A, t_p=8/20\mu s$		16	17.6	V
Junction Capacitance	C_j	Between I/O pins and Ground $V_R=0V, f=1MHz$		0.8	1.0	pF
		Between I/O pins $V_R=0V, f=1MHz$		0.4	0.6	pF

Typical Characteristics

Figure 1: Peak Pulse Power Vs Pulse Time

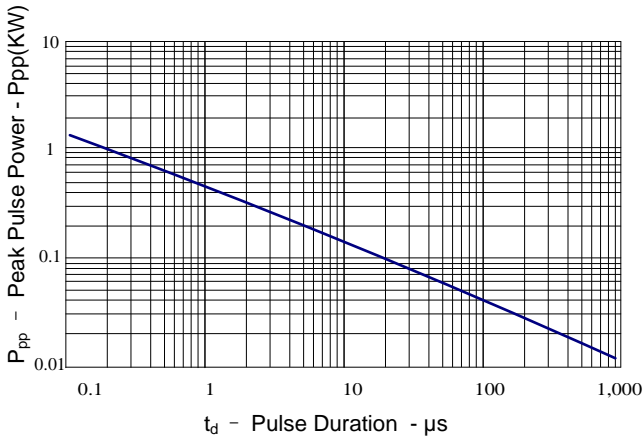

Figure 2: Power Derating Curve

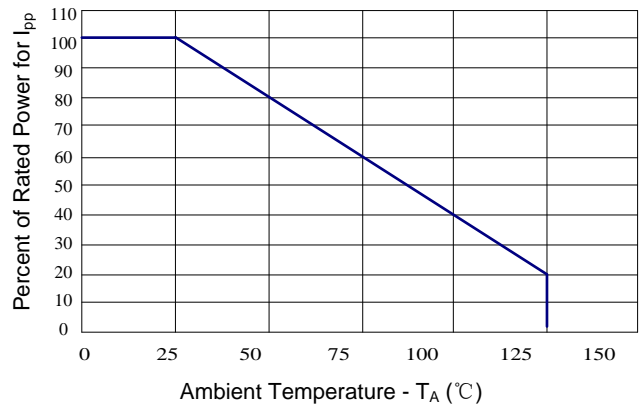

Figure 3: Pulse Waveform

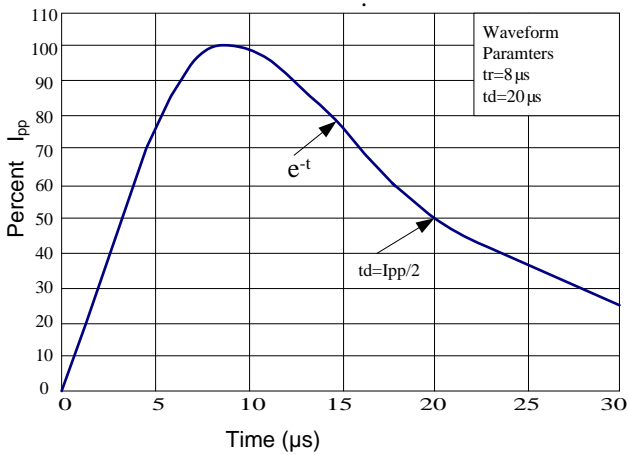

Figure 4: Clamping Voltage vs. Peak Pulse Current

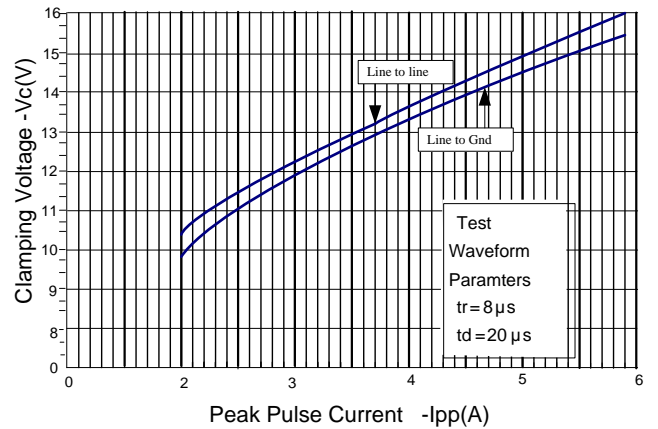

Figure 5: Forward Voltage vs. Forward Current

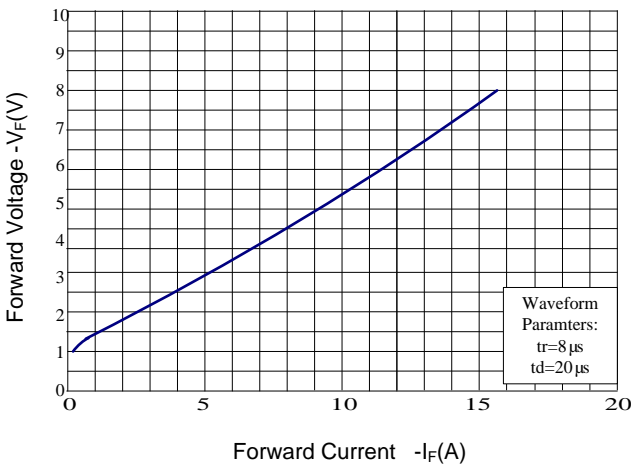
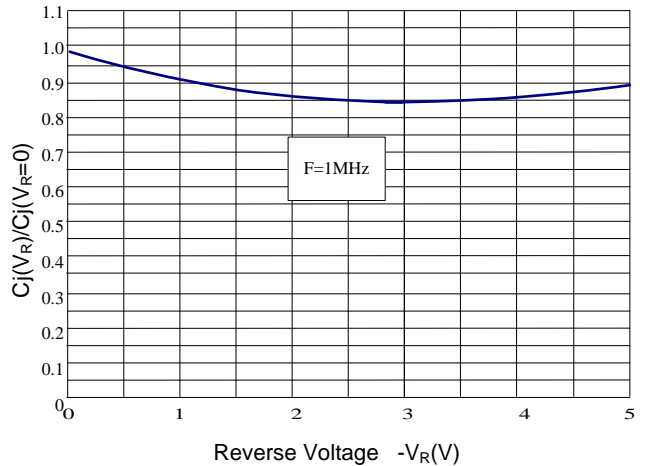

Figure 6: Capacitance vs. Reverse Voltage



Application Information

Device Connection Options for Protection of Two High-Speed Data Lines

The PRTR5V0U2X-N TVS is designed to protect two data lines from transient over-voltages by clamping them to a fixed reference. When the voltage on the protected line exceeds the reference voltage (plus diode V_F) the steering diodes are forward biased, conducting the transient current away from the sensitive circuitry. Data lines are at pins 2 and 3. The negative reference (REF1) is connected at pin 1. This pin should be connected directly to a ground plane on the board for the best results. The path length is kept as short as possible to minimize parasitic inductance. The reference (REF2) is connected at pin 4. The options for connecting the positive reference are as follows:

Data Line and Power Supply Protection Using V_{CC} as reference

1. To protect data lines and the power line, connect pin 4 directly to the positive supply rail (V_{CC}). In this configuration the data lines are referenced to the supply voltage. The internal TVS diode prevents over-voltage to the supply rail.

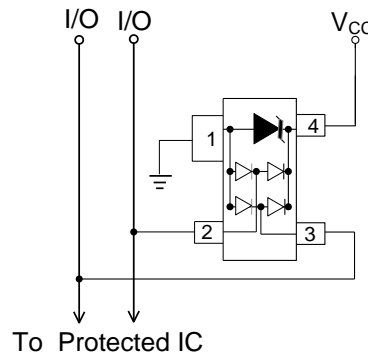

Data Line Protection with Bias and Power Supply Isolation Resistor

2. The PRTR5V0U2X-N can be isolated from the power supply by adding a series resistor between pin 4 and V_{CC} . A value of $10k\Omega$ is recommended. The internal TVS and steering diodes remains biased, providing the advantage of lower capacitance.

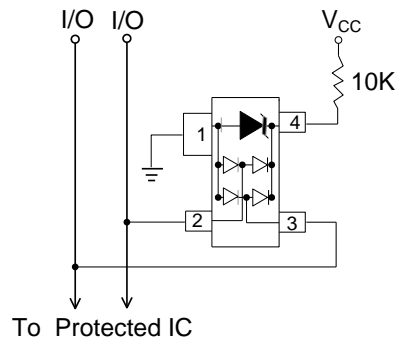

3. In applications where no positive supply reference is available, or complete supply isolation is desired, the internal TVS may be used as the reference. In this case, pin 4 is not connected. The steering diodes will begin to conduct when the voltage on the protected line exceeds the working voltage of the TVS (plus one diode drop).

Data Line Protection Using Internal TVS Diode as Reference

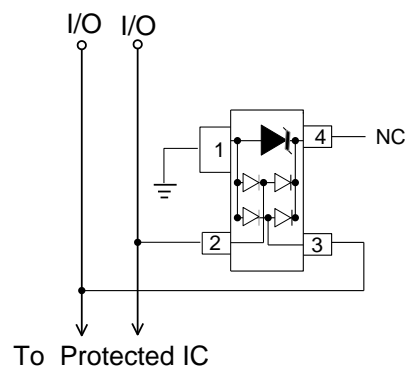

Typical Applications

PRTR5V0U2X-N on HDMI Port Application

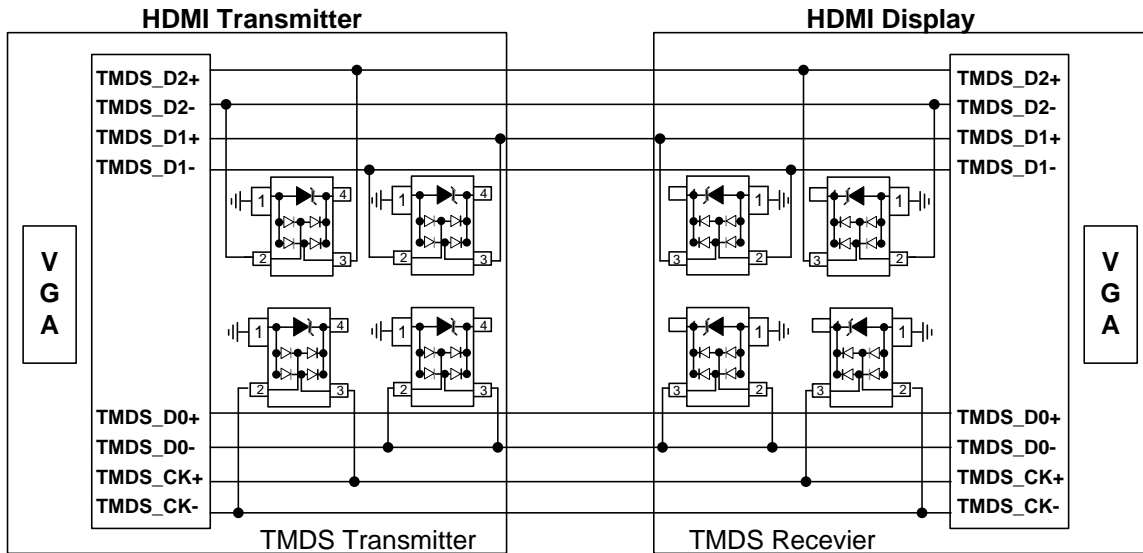

HDMI ports have become standard features on today’s consumer electronics devices, such as digital TVs, DVD recorders, and set top boxes. The small geometry of a HDMI graphic chip will make it more susceptible to ESD and cable discharge events. The high-speed transmission requires the protection device to have low capacitance to maintain signal integrity and low clamping voltage to reduce stress on the IC. The DW05R-E offers full protection against ESD and its low capacitance of 0.4pF, ensures signal integrity.

PRTR5V0U2X-N on USB2.0 Port Application

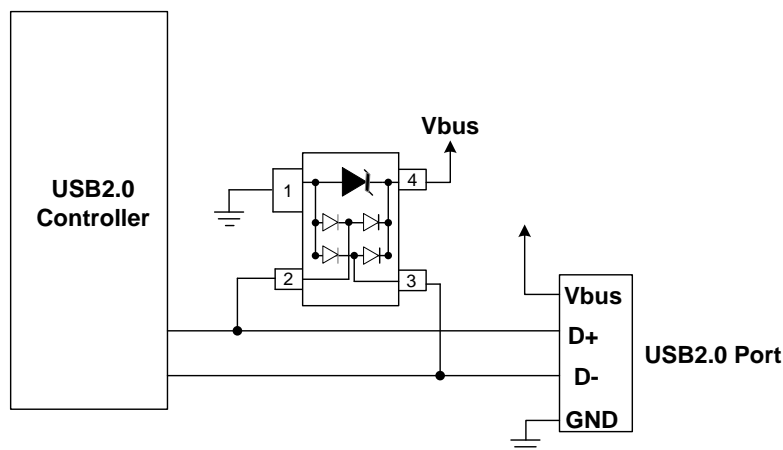

The PRTR5V0U2X-N can also be used to protect USB2.0 ports on monitors, computers, peripherals or portable systems. Each device is able to protect single USB2.0 port. When the voltage on the data lines exceed the bus voltage (plus one diode drop), the internal diodes are forward biased conducting the transient current away from the protected controller chip. The TVS diode directs the surge to ground. The TVS diode also acts to suppress ESD strikes directly on the voltage bus. Thus, both power and data lines are protected.

Outline Drawing – SOT-143

PACKAGE OUTLINE

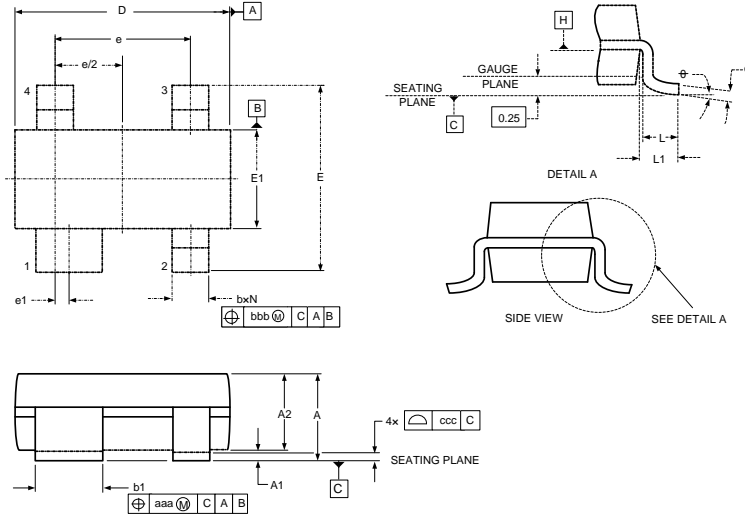

- NOTES:
1. CONTROLLING DIMENSIONS ARE IN MILLIMETERS (ANGLES IN DEGREES).
 2. DATUMS AND TO BE DETERMINED AT DATUM PLANE
 3. DIMENSIONS "E1" AND "D" DO NOT INCLUDE MOLD FLASH, PROTRUSIONS OR GATE BURRS.
 4. REFERENCE JEDEC STD TO-253, VARIATION D.

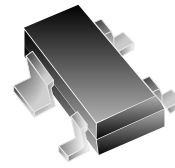

SOT-143

DIMENSIONS

SYMBOL	MILLIMETER		INCHES	
	MIN	MAX	MIN	MAX
A	0.900	1.150	0.035	0.045
A1	0.000	0.100	0.000	0.004
A2	0.900	1.050	0.035	0.041
b	0.300	0.500	0.012	0.020
b1	0.750	0.900	0.030	0.035
c	0.080	0.150	0.003	0.006
D	2.800	3.000	0.110	0.118
e	1.800	2.000	0.071	0.079
e1	0.200TYP		0.008TYP	
E	2.250	2.550	0.089	0.100
E1	1.200	1.400	0.047	0.055
L1	0.550REF		0.022REF	
L	0.300	0.500	0.012	0.020
θ	0°	8°	0°	8°

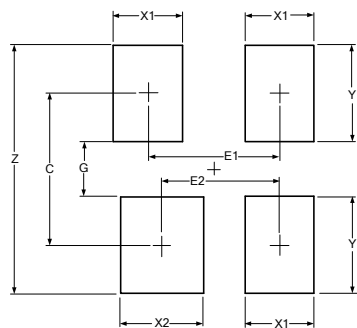

DIMENSIONS		
DIM	INCHES	MILLIMETERS
C	.087	2.20
E1	.076	1.92
E2	.068	1.72
G	.031	0.80
X1	.039	1.00
X2	.047	1.20
y	.055	1.40
z	.141	3.60

Notes

1. This land pattern is for reference purposes only consult your manufacturing group to ensure your company's manufacturing guidelines are met.
2. Reference IPC-SM-782A.

Package Information

Qty: 3k/Reel

X-ON Electronics

Largest Supplier of Electrical and Electronic Components

Click to view similar products for [ESD Suppressors / TVS Diodes](#) category:

Click to view products by [DOWO](#) manufacturer:

Other Similar products are found below :

[60KS200C](#) [D18V0L1B2LP-7B](#) [D5V0F4U5P5-7](#) [NTE4902](#) [P4KE27CA](#) [P6KE11CA](#) [P6KE39CA-TP](#) [P6KE8.2A](#) [JANTX1N6053A](#)
[SA110CA](#) [SA60CA](#) [SA64CA](#) [SMBJ12CATR](#) [SMBJ33CATR](#) [SMBJ8.0A](#) [ESD101-B1-02ELS E6327](#) [ESD105-B1-02EL E6327](#) [ESD112-B1-02EL E6327](#) [ESD119B1W01005E6327XTSA1](#) [ESD5V0L1B02VH6327XTSA1](#) [ESD7451N2T5G](#) [19180-510](#) [CPDT-5V0USP-HF](#)
[3.0SMCJ33CA-F](#) [3.0SMCJ36A-F](#) [HSPC16701B02TP](#) [JANTX1N6126A](#) [JANTX1N6462](#) [JANTX1N6465](#) [USB50805e3/TR7](#)
[D3V3Q1B2DLP3-7](#) [D55V0M1B2WS-7](#) [DRTR5V0U4SL-7](#) [SCM1293A-04SO](#) [ESD200-B1-CSP0201 E6327](#) [SM12-7](#) [SM1605E3/TR13](#)
[SMLJ45CA-TP](#) [CEN955 W/DATA](#) [82350120560](#) [VESD12A1A-HD1-GS08](#) [CPDUR5V0R-HF](#) [CPDQC5V0U-HF](#) [CPDQC5V0USP-HF](#)
[CPDQC5V0-HF](#) [D1213A-01LP4-7B](#) [ESD101-B1-02EL E6327](#) [824500181](#) [MMAD1108/TR13](#) [5KP100A](#)