



Working Voltage: 11 to 43 V

Peak Pulse Power: 6600 W

Surface Mount Transient Voltage Suppressors

Features

- Glass passivated chip
- 6600 W peak pulse power capability with a 10/1000 μ s waveform, repetitive rate (duty cycle):0.01 %
- Meet ISO7637-2 5a surge specification
- Meet AEC-Q101 requirement
- Low leakage current
- Bidirectional unit
- Excellent clamping capability
- Very fast response time
- RoHS compliant

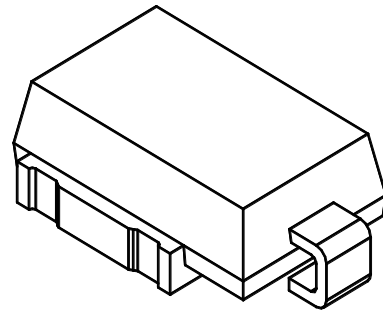

DO-218AB

Mechanical Data

- Case: DO-218AB
- Epoxy: UL 94V-0 rate flame retardant

Maximum Ratings($T_A=25^\circ\text{C}$ unless otherwise noted)

Parameter	Symbol	Value	Unit
Peak power dissipation with a 10/1000 μ s waveform ⁽¹⁾	P_{PP}	6600	W
Peak power dissipation with a 10/10,000 μ s waveform	P_{PP}	3650	W
Peak pulse current with a 10/1000 μ s waveform ⁽¹⁾	I_{PP}	See Next Table	A
Power dissipation on infinite heatsink at $T_L = 25^\circ\text{C}$	P_D	8.0	W
Operating junction and storage temperature range	T_J, T_{STG}	- 55 to +175	$^\circ\text{C}$

Note:

(1)Non-repetitive current pulse per Fig.2 and derated above $T_A=25^\circ\text{C}$ per Fig.1

Ratings and Characteristics Curves ($T_A=25^\circ\text{C}$ unless otherwise noted)

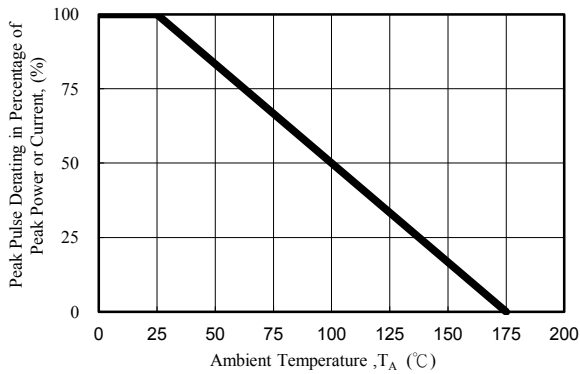

Fig. 1 - Pulse Derating Curve

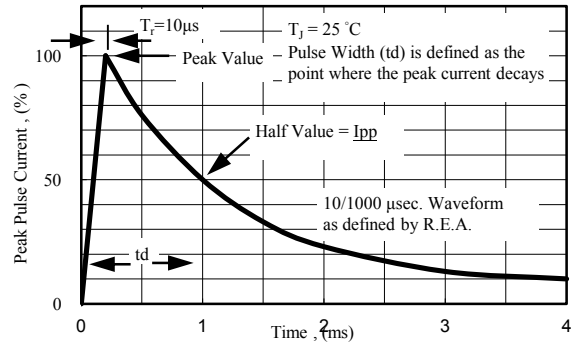

Fig. 2 - Pulse Waveform

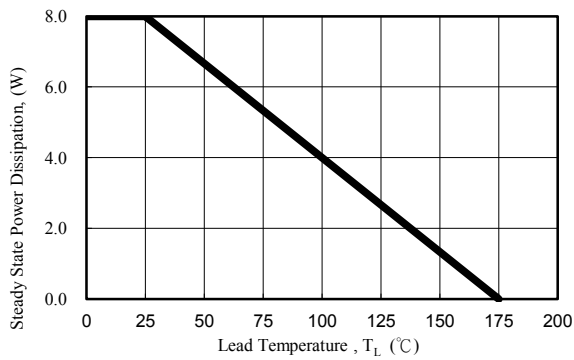
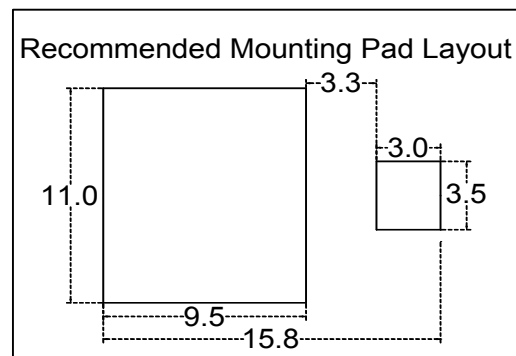
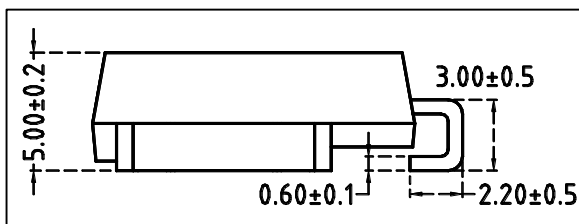
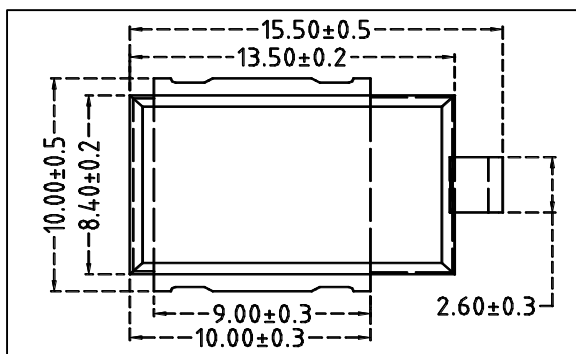

Fig. 3 - Steady State Power Derating Curve

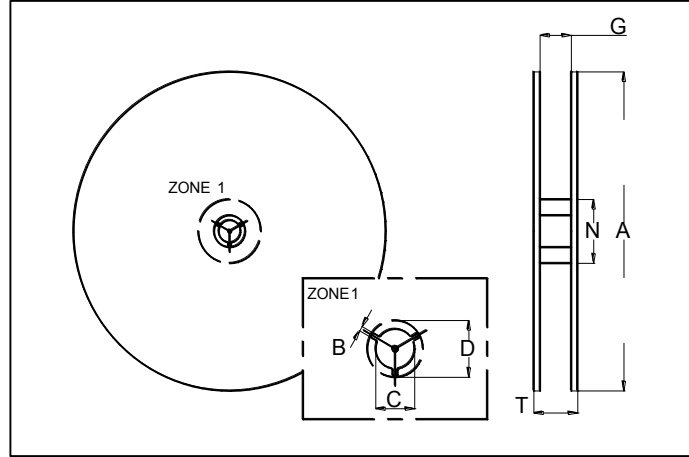
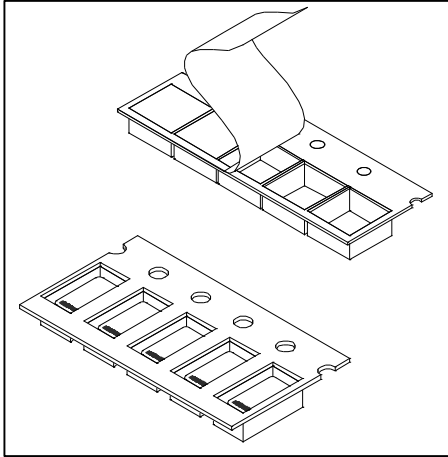

Fig. 4 - Peak Pulse Power Rating Curve

Package Outline Dimensions (Millimeters)



Surface Mount Tape and Reel Packaging



Dimensions in Millimeters (inches)

TAPE SIZE	A MAX.	B MIN.	C	D MIN.	N MIN.	G MAX.	T MAX.
24 mm (0.945)	330 ± 2.0 (13.0 \pm 0.079)	1.5 (0.059)	13.5 ± 0.50 (0.53 \pm 0.02)	20.2 (0.795)	50 (1.97)	26.4 (1.039)	30.4 (1.197)

Recommended Soldering Parameters

IR-Reflow Condition			
Pre Heat	Temp. min	150	°C
	Temp. max	200	°C
	Time(min to max)	60-180	sec
Ramp up rate (150-200°C)		<3	°C/sec

Reflow	Liquidus Temp.	>220	°C
	Peak Temp.	245	°C
	Time(Liq. to Peak)	60-150	sec
Ramp up rate (220-200°C)		<3	°C/sec
Time within actual peak temp.		10-30	sec

Ramp down Rate	<5	°C/sec
Time(25°C to Peak temp.)	<6	min
Do not exceed	280	°C

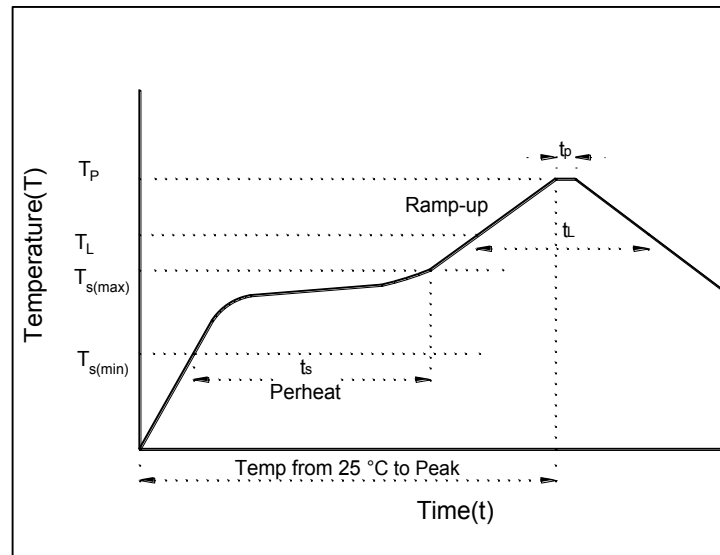

Electrical Characteristics($T_A=25^{\circ}\text{C}$ unless otherwise noted)

Part Number (Bi)	Breakdown Voltage V_{BR} @ I_T			Maximum Reverse Leakage I_R @ V_{RWM} (uA)	Maximum I_R @ V_{RWM} $T_J=150$ (uA)	Working Peak Reverse Voltage V_{RWM} (V)	Maximum Reverse Surge Current I_{PP} (A) ⁽¹⁾	Maximum Clamping Voltage V_C @ I_{PP} (V)
	Min (V)	Max (V)	I_T (mA)					
SM8S11CA	12.20	13.50	5	10	150	11	363.00	18.2
SM8S14CA	15.60	17.20	5	10	150	14	284.00	23.2
SM8S15CA	16.70	18.50	5	10	150	15	270.00	24.4
SM8S16CA	17.80	19.70	5	10	150	16	254.00	26.0
SM8S17CA	18.90	20.90	5	10	150	17	239.00	27.6
SM8S18CA	20.00	22.10	5	10	150	18	226.00	29.2
SM8S20CA	22.20	24.50	5	10	150	20	204.00	32.4
SM8S22CA	24.40	26.90	5	10	150	22	186.00	35.5
SM8S24CA	26.70	29.50	5	10	150	24	170.00	38.9
SM8S26CA	28.90	31.90	5	10	150	26	157.00	42.1
SM8S28CA	31.10	34.40	5	10	150	28	145.00	45.4
SM8S30CA	33.30	36.80	5	10	150	30	136.00	48.4
SM8S33CA	36.70	40.60	5	10	150	33	124.00	53.3
SM8S36CA	40.00	44.20	5	10	150	36	114.00	58.1
SM8S40CA	44.40	49.10	5	10	150	40	102.00	64.5
SM8S43CA	47.80	52.80	5	10	150	43	95.10	69.4

NOTE: Surge current waveform is defined at 10/1000uS waveform

X-ON Electronics

Largest Supplier of Electrical and Electronic Components

Click to view similar products for [ESD Suppressors / TVS Diodes](#) category:

Click to view products by [DOWO](#) manufacturer:

Other Similar products are found below :

[60KS200C](#) [D18V0L1B2LP-7B](#) [D5V0F4U5P5-7](#) [NTE4902](#) [P4KE27CA](#) [P6KE11CA](#) [P6KE8.2A](#) [SA60CA](#) [SA64CA](#) [SMBJ12CATR](#)
[SMBJ33CATR](#) [SMBJ6.5A](#) [SMBJ8.0A](#) [ESD101-B1-02ELS E6327](#) [ESD112-B1-02EL E6327](#) [ESD7451N2T5G](#) [19180-510](#) [CPDT-5V0USP-](#)
[HF](#) [3.0SMCJ33CA-F](#) [3.0SMCJ36A-F](#) [HSPC16701B02TP](#) [JANTX1N6126A](#) [D3V3Q1B2DLP3-7](#) [D55V0M1B2WS-7](#) [SCM1293A-04SO](#)
[ESD200-B1-CSP0201 E6327](#) [SM12-7](#) [CEN955 W/DATA](#) [VESD12A1A-HD1-GS08](#) [CPDQC5V0-HF](#) [D1213A-01LP4-7B](#) [ESD101-B1-02EL](#)
[E6327](#) [AOZ8808DI-03](#) [5KP15A](#) [5KP48A](#) [5KP90A](#) [ESD3V3D7-TP](#) [15KPA36A-LF](#) [P4KE56CA](#) [P4KE68A](#) [P4KE91CATR](#) [P6KE120A](#)
[P6KE13CA](#) [P6KE43CA](#) [P6KE6.8CA](#) [P6KE8.2](#) [P6SMBJ20CA](#) [JANTX1N6072A](#) [SR2835ESKG](#) [SA90CA](#)