

REVISIONS

LTR	DESCRIPTION	DATE (YR-MO-DA)	APPROVED
A	Added Arrhenius equation for unbiased bake under margin test method A, back end margin test step C. Corrected military part numbers for device types 01 and 02. Technical changes made to 1.2.2, table I, figure 1, figure 2, figure 4, figure 5, 4.3.1, and table II. Added vendor CAGE 34649 for device type 05. Editorial changes throughout.	89-01-19	M. A. Frye
B	Add device type 08 for vendor CAGE number 66579. Add vendor CAGE number 34335 to the drawing as a source of supply for the 08 device with changes to table I. Deleted programming cycle timing waveform and table III from drawing. Also deleted ESDS from drawing. Editorial changes throughout.	89-10-30	M. A. Frye
C	Deleted vendor CAGE number 34335 as a source of supply for device type 08. Added vendor CAGE number 34335 as a source of supply for device types 01 through 07. Deleted figure 5. Editorial changes throughout.	90-02-26	M. A. Frye
D	Changes in accordance with NOR 5962-R079-95.	95-02-15	M. A. Frye
E	Added provisions for QD certification. Added CAGE 0C7V7 to drawing as a source of supply for device type 07. Updated boilerplate. - glg	99-12-03	Raymond Monnin
F	Boilerplate update, part of 5 year review. ksr	06-09-29	Raymond Monnin
G	Corrected footnote 1/ on section 1.2.2 package style heading to include all packages. Corrected test method number in 4.3.2 b (1). ksr	09-03-30	Robert M. Heber

The original first page of this drawing has been replaced.

REV																				
SHEET																				
REV																				
SHEET																				

REV STATUS	REV	G	G	G	G	G	G	G	G	G	G	G	G	G						
OF SHEETS	SHEET	1	2	3	4	5	6	7	8	9	10	11								

PMIC N/A	PREPARED BY Rick C. Officer	DEFENSE SUPPLY CENTER COLUMBUS																	
<p align="center">STANDARD MICROCIRCUIT DRAWING</p> <p>THIS DRAWING IS AVAILABLE FOR USE BY ALL DEPARTMENTS AND AGENCIES OF THE DEPARTMENT OF DEFENSE</p> <p align="center">AMSC N/A</p>	CHECKED BY D. A. DiCenzo	COLUMBUS, OHIO 43218-3990 http://www.dscc.dla.mil																	
	APPROVED BY Robert P. Evans	MICROCIRCUIT, MEMORY, DIGITAL, CMOS, 16K X 8-BIT ULTRA VIOLET ERASABLE PROGRAMMABLE READ ONLY MEMORY (UVEPROM), MONOLITHIC SILICON																	
	DRAWING APPROVAL DATE 87-10-23	SIZE A	CAGE CODE 67268	5962-87661															
	REVISION LEVEL G	SHEET 1 OF 11																	

1. SCOPE

1.1 Scope. This drawing describes device requirements for MIL-STD-883 compliant, non-JAN class level B microcircuits in accordance with MIL-PRF-38535, appendix A.

1.2 Part or Identifying Number (PIN). The complete PIN is as shown in the following example:

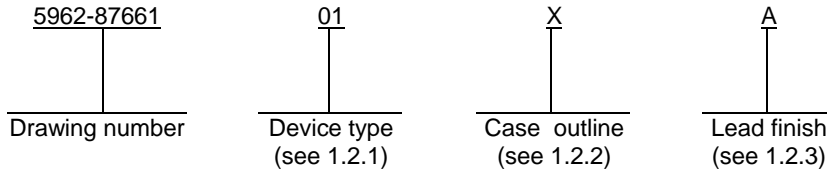

1.2.1 Device type(s). The device type(s) identify the circuit function as follows:

Device type	Generic number 1/	Circuit function	Access time
01	27C128	16K x 8-bit UVEPROM	90 ns
02	27C128	16K x 8-bit UVEPROM	120 ns
03	27C128	16K x 8-bit UVEPROM	150 ns
04	27C128	16K x 8-bit UVEPROM	170 ns
05	27C128	16K x 8-bit UVEPROM	200 ns
06	27C128	16K x 8-bit UVEPROM	250 ns
07	27C128	16K x 8-bit UVEPROM	300 ns
08	27C128	16K x 8-bit UVEPROM	70 ns

1.2.2 Case outline(s). The case outline(s) are as designated in MIL-STD-1835 and as follows:

Outline letter	Descriptive designator	Terminals	Package style 1/
X	GDIP1-T28 or CDIP2-T28	28	dual-in-line package
Y	CQCC1-N32	32	rectangular leadless chip carrier

1.2.3 Lead finish. The lead finish is as specified in MIL-PRF-38535, appendix A.

1.3 Absolute maximum ratings. 2/

Supply voltage range (V_{CC}) 2/	-0.6 V dc to 6.25 V dc
Supply voltage range (V_{PP}) 2/	-0.6 V dc to 14.0 V dc
All input voltage range except A_9 2/	-0.6 V dc to 6.25 V dc
Input voltage range (A_9) 2/	-0.6 V dc to 13.5 V dc
Output voltage range 2/	-0.6 V dc to $V_{CC} + 1.0$ V dc
Storage temperature range	-65°C to +150°C
Power dissipation	300 mW
Lead temperature (soldering, 10 seconds)	+300°C
Thermal resistance, junction-to-case (θ_{JC})	See MIL-STD-1835
Junction temperature (T_J)	+150°C 3/
Data retention	10 years minimum

1.4 Recommended operating conditions.

Supply voltage range (V_{CC}) 4/	4.5 V dc to 5.5 V dc
Supply voltage range (V_{PP}) 5/	4.5 V dc to 5.5 V dc
High level input voltage range (V_{IH})	2.0 V dc to 6.5 V dc (TTL)
High level input voltage range (V_{IH})	$V_{CC} - 0.2$ V dc to $V_{CC} + 0.2$ V dc (CMOS)
Low level input voltage range (V_{IL})	-0.1 V dc to 0.8 V dc (TTL)
Low level input voltage range (V_{IL})	GND -0.2 to GND +0.2 V dc (CMOS)
Case operating temperature range (T_C)	-55°C to +125°C

1/ Lid shall be transparent to permit ultraviolet light erasure.

2/ Under absolute maximum ratings, voltages are with respect to GND.

3/ Maximum junction temperature may be increased to +175°C during burn-in and steady-state life.

4/ V_{CC} must be applied before or at the same time as V_{PP} and removed after or at the same time as V_{PP} . The device must not be inserted into or removed from the board when V_{PP} or V_{CC} is applied.

5/ V_{PP} can be connected to V_{CC} directly (except in the program mode). V_{CC} supply current in this case would be $I_{CC} + I_{PP}$. During programming, V_{PP} must be maintained at 12.5 V (± 0.5 V).

STANDARD MICROCIRCUIT DRAWING DEFENSE SUPPLY CENTER COLUMBUS COLUMBUS, OHIO 43218-3990	SIZE A	REVISION LEVEL G	5962-87661 SHEET 2
---	------------------	----------------------------	--

2. APPLICABLE DOCUMENTS

2.1 Government specification, standards, and handbooks. The following specification, standards, and handbooks form a part of this drawing to the extent specified herein. Unless otherwise specified, the issues of these documents are those cited in the solicitation or contract.

DEPARTMENT OF DEFENSE SPECIFICATION

MIL-PRF-38535 - Integrated Circuits, Manufacturing, General Specification for.

DEPARTMENT OF DEFENSE STANDARDS

MIL-STD-883 - Test Method Standard Microcircuits.
MIL-STD-1835 - Interface Standard Electronic Component Case Outlines.

DEPARTMENT OF DEFENSE HANDBOOKS

MIL-HDBK-103 - List of Standard Microcircuit Drawings.
MIL-HDBK-780 - Standard Microcircuit Drawings.

(Copies of these documents are available online at <http://assist.daps.dla.mil/quicksearch/> or <http://assist.daps.dla.mil> or from the Standardization Document Order Desk, 700 Robbins Avenue, Building 4D, Philadelphia, PA 19111-5094.)

2.2 Order of precedence. In the event of a conflict between the text of this drawing and the references cited herein, the text of this drawing takes precedence. Nothing in this document, however, supersedes applicable laws and regulations unless a specific exemption has been obtained.

3. REQUIREMENTS

3.1 Item requirements. The individual item requirements shall be in accordance with MIL-PRF-38535, appendix A for non-JAN class level B devices and as specified herein. Product built to this drawing that is produced by a Qualified Manufacturer Listing (QML) certified and qualified manufacturer or a manufacturer who has been granted transitional certification to MIL-PRF-38535 may be processed as QML product in accordance with the manufacturers approved program plan and qualifying activity approval in accordance with MIL-PRF-38535. This QML flow as documented in the Quality Management (QM) plan may make modifications to the requirements herein. These modifications shall not affect form, fit, or function of the device. These modifications shall not affect the PIN as described herein. A "Q" or "QML" certification mark in accordance with MIL-PRF-38535 is required to identify when the QML flow option is used.

3.2 Design, construction, and physical dimensions. The design, construction, and physical dimensions shall be as specified in MIL-PRF-38535, appendix A and herein.

3.2.1 Terminal connections. The terminal connections shall be as specified on figure 1.

3.2.2 Truth table. The truth table shall be as specified on figure 2.

3.2.2.1 Unprogrammed devices. The truth table for unprogrammed devices shall be as specified on figure 2.

3.2.2.2 Programmed devices. The requirements for supplying programmed devices are not part of this drawing.

3.2.3 Case outlines. The case outlines shall be in accordance with 1.2.2 herein.

3.3 Electrical performance characteristics. Unless otherwise specified herein, the electrical performance characteristics are as specified in table I and shall apply over the full case operating temperature range.

3.4 Electrical test requirements. The electrical test requirements shall be the subgroups specified in table II. The electrical tests for each subgroup are described in table I.

STANDARD MICROCIRCUIT DRAWING DEFENSE SUPPLY CENTER COLUMBUS COLUMBUS, OHIO 43218-3990	SIZE A		5962-87661
		REVISION LEVEL G	SHEET 3

TABLE I. Electrical performance characteristics.

Test	Symbol	Conditions -55°C ≤ T _C ≤ +125°C 4.5 V ≤ V _{CC} ≤ 5.5 V unless otherwise specified	Device types	Group A subgroups	Limits		Unit
					Min	Max	
High level output voltage	V _{OH}	I _{OH} = -400 μA	All	1,2,3	2.4		V
Low level output voltage	V _{OL}	I _{OL} = 2.1 mA	All	1,2,3		0.45	V
Input current (leakage)	I _I	V _I = 0 V to 5.5 V	All	1,2,3		±10	μA
Output current (leakage)	I _O	V _O = 0 V to V _{CC}	All	1,2,3		±10	μA
V _{PP} supply current	I _{PP1}	V _{PP} = V _{CC} = 5.5 V	All	1,2,3		100	μA
V _{PP} supply current (during program pulse) 1/	I _{PP2}	V _{PP} = 13 V	01-07	1		50	mA
			08			60	
Operating supply current (active)	I _{CC1}	V _{CC} = 5.5 V, $\overline{CE} = V_{IL}$, f = 1/t _{AVQV} , 0 ₁ -0 ₈ = 0 mA	03,04, 05,06, 07	1,2,3		25	mA
			08			85	
			01			70	
			02			60	
Standby power supply current (TTL)	I _{CC2}	V _{CC} = 5.5 V, $\overline{CE} = 2.0$ V, f = 0	01-07	1,2,3		3.0	mA
			08			200	
Standby power supply current (CMOS)	I _{CC3}	V _{CC} = 5.5 V, $\overline{CE} = V_{CC}$, f = 0	01-07	1,2,3		300	μA
			08			500	
Input capacitance	C _{IN}	V _I = 0 V, f = 1 MHz, see 4.3.1c	All	4		10	pF
Output capacitance	C _{OUT}	V _O = 0 V, f = 1 MHz, see 4.3.1c	All	4		14	pF
Functional tests		see 4.3.1e	All	7,8A,8B			

See footnotes at end of table.

STANDARD MICROCIRCUIT DRAWING DEFENSE SUPPLY CENTER COLUMBUS COLUMBUS, OHIO 43218-3990	SIZE A		5962-87661
		REVISION LEVEL G	SHEET 4

TABLE I. Electrical performance characteristics - Continued.

Test	Symbol	Conditions -55°C ≤ T _C ≤ +125°C 4.5 V ≤ V _{CC} ≤ 5.5 V unless otherwise specified	Device types	Group A subgroups	Limits		Unit
					Min	Max	
Address access time <u>2/</u>	t _{AVQV}	See figures 3 and 4	01 02 03 04 05 06 07 08	9,10,11		90 120 150 170 200 250 300 70	ns
Chip enable access time <u>2/</u>	t _{ELQV}	See figures 3 and 4	01 02 03 04 05 06 07 08	9,10,11		90 120 150 170 200 250 300 70	ns
Output enable access time <u>2/</u>	t _{OLQV}	See figures 3 and 4	01,02 03,04 05 06 07 08	9,10,11		50 70 75 100 120 25	ns
$\overline{\text{CE}}$ or $\overline{\text{OE}}$ disable to output in high Z <u>1/</u>	t _{EHQZ} , t _{OHQZ}	See figures 3 and 4	01,02 03,04	9,10,11		50	ns
			05,06			60	
			07			105	
			08			25	
$\overline{\text{CE}}$ or $\overline{\text{OE}}$ enable to output valid <u>1/</u>	t _{EHQV} , t _{OHQV}	See figures 3 and 4	All	9,10,11	0		ns

1/ May not be tested, but shall be guaranteed to the limits specified in table I.

2/ For all switching characteristics and timing measurements, inputs pulse levels are 0.40 V and 2.4 V and V_{PP} = 12.5 V ± 0.5 V during programming.

**STANDARD
MICROCIRCUIT DRAWING**
DEFENSE SUPPLY CENTER COLUMBUS
COLUMBUS, OHIO 43218-3990

SIZE
A

REVISION LEVEL
G

5962-87661

SHEET
5

Device types	ALL	
Case Outlines	X	Y
Terminal Number	Terminal Symbol	
1	V _{PP}	NC
2	A ₁₂	V _{PP}
3	A ₇	A ₁₂
4	A ₆	A ₇
5	A ₅	A ₆
6	A ₄	A ₅
7	A ₃	A ₄
8	A ₂	A ₃
9	A ₁	A ₂
10	A ₀	A ₁
11	O ₁	A ₀
12	O ₂	NC
13	O ₃	O ₁
14	GND	O ₂
15	O ₄	O ₃
16	O ₅	GND
17	O ₆	NC
18	O ₇	O ₄
19	O ₈	O ₅
20	\overline{CE}	O ₆
21	A ₁₀	O ₇
22	\overline{OE}	O ₈
23	A ₁₁	\overline{CE}
24	A ₉	A ₁₀
25	A ₈	\overline{OE}
26	A ₁₃	NC
27	\overline{PGM}	A ₁₁
28	V _{CC}	A ₉
29	---	A ₈
30	---	A ₁₃
31	---	\overline{PGM}
32	---	V _{CC}

NC = no connection

FIGURE 1. Terminal connections.

STANDARD MICROCIRCUIT DRAWING DEFENSE SUPPLY CENTER COLUMBUS COLUMBUS, OHIO 43218-3990	SIZE A		5962-87661
		REVISION LEVEL G	SHEET 6

Mode	Function pins (see note 1)							
	\overline{CE}	\overline{OE}	\overline{PGM}	V_{PP}	V_{CC}	A_9	A_0	$O_1 - O_8$
Read	V_{IL}	V_{IL}	V_{IH}	V_{CC}	V_{CC}	X	X	D_{OUT}
Output disable	V_{IL}	V_{IH}	V_{IH}	V_{CC}	V_{CC}	X	X	HIGH-Z
Standby	V_{IH}	X	X	V_{CC}	V_{CC}	X	X	HIGH-Z
Programming	V_{IL}	V_{IH}	V_{IL}	V_{PP}	V_{CC}	X	X	D_{IN}
Verify	V_{IL}	V_{IL}	V_{IH}	V_{PP}	V_{CC}	X	X	D_{OUT}
Program inhibit	V_{IH}	X	X	V_{PP}	V_{CC}	X	X	HIGH-Z
Signature mode (see notes 2, 3, and 4)	V_{IL}	V_{IL}	V_{IH}	V_{CC}	V_{CC}	VH	V_{IL}	MFG code
						VH	V_{IH}	Device code

NOTES:

1. X can be V_{IL} or V_{IH} .
2. VH = 12 V \pm 0.5 V.
3. All other address must be held at V_{IL} .
4. See 6.6.

FIGURE 2. Truth table.

STANDARD MICROCIRCUIT DRAWING DEFENSE SUPPLY CENTER COLUMBUS COLUMBUS, OHIO 43218-3990	SIZE A		5962-87661
		REVISION LEVEL G	SHEET 7

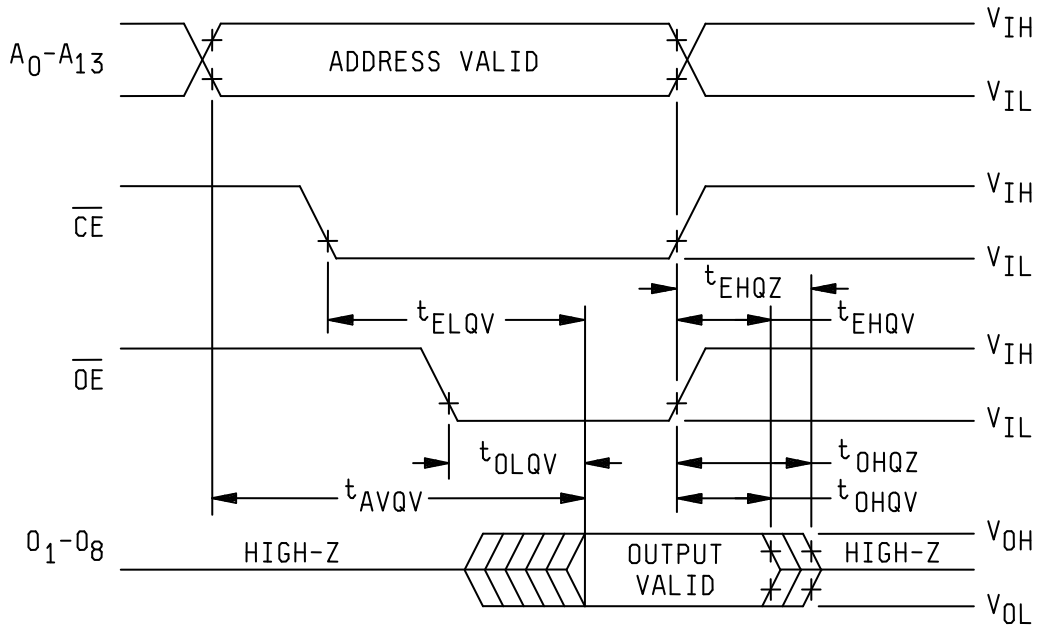

FIGURE 3. Read cycle timing waveform.

PARAMETER MEASUREMENT INFORMATION

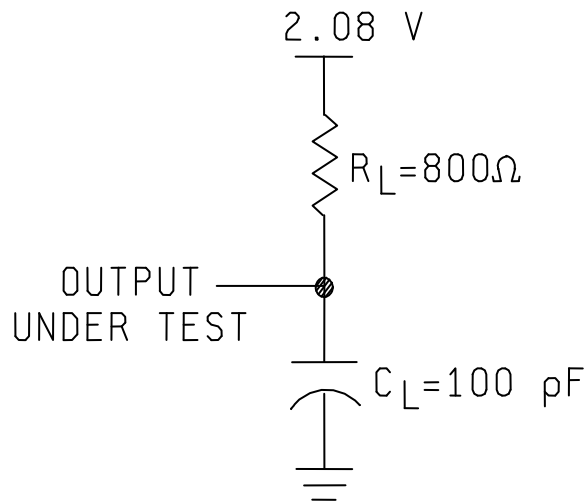

FIGURE 4. Output load circuit.

STANDARD MICROCIRCUIT DRAWING DEFENSE SUPPLY CENTER COLUMBUS COLUMBUS, OHIO 43218-3990	SIZE A		5962-87661
		REVISION LEVEL G	SHEET 8

3.5 Marking. Marking shall be in accordance with MIL-PRF-38535, appendix A. The part shall be marked with the PIN listed in 1.2 herein. In addition, the manufacturer's PIN may also be marked. For packages where marking of the entire SMD PIN number is not feasible due to space limitations, the manufacturer has the option of not marking the "5962-" on the device.

3.5.1 Certification/compliance mark. A compliance indicator "C" shall be marked on all non-JAN devices built in compliance to MIL-PRF-38535, appendix A. The compliance indicator "C" shall be replaced with a "Q" or "QML" certification mark in accordance with MIL-PRF-38535 to identify when the QML flow option is used.

3.6 Processing EPROMS. All testing requirements and quality assurance provisions herein shall be specified by the manufacturer prior to delivery.

3.6.1 Erasure of EPROMS. When specified, devices shall be erased in accordance with the procedures and characteristics specified in 4.4.

3.6.2 Programmability of EPROMS. When specified, devices shall be programmed to the specified pattern using the procedures and characteristics specified in 4.5.

3.6.3 Verification of erasure or programmability of EPROMS. When specified, devices shall be verified as either programmed to the specified program or erased. As a minimum, verification shall consist of performing a functional test (subgroup 7) to verify that all bits are in the proper state. Any bit that does not verify to be in the proper state shall constitute a failure, and shall be removed from the lot.

3.7 Certificate of compliance. A certificate of compliance shall be required from a manufacturer in order to be listed as an approved source of supply in MIL-HDBK-103 (see 6.6 herein). The certificate of compliance submitted to DSCC-VA prior to listing as an approved source of supply shall affirm that the manufacturer's product meets the requirements of MIL-PRF-38535, appendix A and the requirements herein.

3.8 Certificate of conformance. A certificate of conformance as required in MIL-PRF-38535, appendix A shall be provided with each lot of microcircuits delivered to this drawing.

3.9 Notification of change. Notification of change to DSCC-VA shall be required for any change that affects this drawing.

3.10 Verification and review. DSCC, DSCC's agent, and the acquiring activity retain the option to review the manufacturer's facility and applicable required documentation. Offshore documentation shall be made available onshore at the option of the reviewer.

3.11 Data retention. A data retention stress test shall be completed as part of the vendor's reliability monitors. This test shall be done initially and after any design or process change which may affect data retention. The methods and procedures may be vendor specific, but will guarantee the number of years listed in section 1.3 herein over the full military temperature range. The vendor's procedure shall be kept under document control and shall be made available upon request.

4. VERIFICATION

4.1 Sampling and inspection. Sampling and inspection procedures shall be in accordance with MIL-PRF-38535, appendix A.

4.2 Screening. Screening shall be in accordance with method 5004 of MIL-STD-883, and shall be conducted on all devices prior to quality conformance inspection. The following additional criteria shall apply:

a. Burn-in test, method 1015 of MIL-STD-883.

(1) Test condition A, B, C, or D. The test circuit shall be maintained by the manufacturer under document revision level control and shall be made available to the preparing activity upon request. The test circuit shall specify the inputs, outputs, biases, and power dissipation, as applicable, in accordance with the intent specified in method 1015 of MIL-STD-883.

(2) $T_A = +125^\circ\text{C}$, minimum.

b. Interim and final electrical test parameters shall be as specified in table II herein, except interim electrical parameter tests prior to burn-in are optional at the discretion of the manufacturer.

STANDARD MICROCIRCUIT DRAWING DEFENSE SUPPLY CENTER COLUMBUS COLUMBUS, OHIO 43218-3990	SIZE A		5962-87661
		REVISION LEVEL G	SHEET 9

4.3 Quality conformance inspection. Quality conformance inspection shall be in accordance with method 5005 of MIL-STD-883 including groups A, B, C, and D inspections. The following additional criteria shall apply.

4.3.1 Group A inspection.

- a. Tests shall be as specified in table II herein.
- b. Subgroups 5 and 6 in table I, method 5005 of MIL-STD-883 shall be omitted.
- c. Subgroup 4 (C_{IN} and C_{OUT} measurement) shall be measured only for the initial test and after process or design changes which may affect capacitance. Sample size is fifteen devices with no failures and all input and output terminals tested.
- d. All devices selected for testing shall have a checkerboard pattern or equivalent. After completion of all testing, the devices shall be verified and erased (except devices submitted for groups C and D testing).
- e. Subgroups 7, 8A, and 8B shall include verification of the truth table.

TABLE II. Electrical test requirements. 1/ 2/ 3/

MIL-STD-883 test requirements	Subgroups (in accordance with method 5005, table I)
Interim electrical parameters (method 5004)	---
Final electrical test parameters (method 5004)	1*, 2, 3, 7, 8A, 8B, 9, 10, 11
Group A test requirements (method 5005)	1, 2, 3, 4**, 7, 8A, 8B, 9, 10, 11
Groups C and D end-point electrical parameters (method 5005)	2, 8A, 10 or 1, 2, 3

1/ * Indicates PDA applies to subgroups 1.

2/ Any or all subgroups may be combined when using high-speed testers.

3/ ** See 4.3.1c.

4.3.2 Groups C and D inspections.

- a. End-point electrical parameters shall be as specified in table II herein.
- b. Steady-state life test conditions, method 1005 of MIL-STD-883.
 - (1) Test condition A, B, C, or D. The test circuit shall be maintained by the manufacturer under document revision level control and shall be made available to the preparing activity upon request. The test circuit shall specify the inputs, outputs, biases, and power dissipation, as applicable, in accordance with the intent specified in method 1005 of MIL-STD-883.
 - (2) $T_A = +125^\circ\text{C}$, minimum.
 - (3) Test duration: 1,000 hours, except as permitted by method 1005 of MIL-STD-883.
- c. All devices selected for testing shall be programmed with a checkerboard pattern, then verified and erased.

4.4 Erasing procedures. The recommended erasing procedure shall be as specified by the device manufacturer and shall be made available upon request.

4.5 Programming procedures. The programming procedures shall be as specified by the device manufacturer and shall be made available upon request.

STANDARD MICROCIRCUIT DRAWING DEFENSE SUPPLY CENTER COLUMBUS COLUMBUS, OHIO 43218-3990	SIZE A		5962-87661
		REVISION LEVEL G	SHEET 10

5. PACKAGING

5.1 Packaging requirements. The requirements for packaging shall be in accordance with MIL-PRF-38535, appendix A.

6. NOTES

6.1 Intended use. Microcircuits conforming to this drawing are intended for use for Government microcircuit applications (original equipment), design applications, and logistics purposes.

6.2 Replaceability. Microcircuits covered by this drawing will replace the same generic device covered by a contractor-prepared specification or drawing.

6.3 Configuration control of SMD's. All proposed changes to existing SMD's will be coordinated with the users of record for the individual documents. This coordination will be accomplished using DD Form 1692, Engineering Change Proposal.

6.4 Record of users. Military and industrial users shall inform Defense Supply Center Columbus (DSCC) when a system application requires configuration control and the applicable SMD. DSCC will maintain a record of users and this list will be used for coordination and distribution of changes to the drawings. Users of drawings covering microelectronics devices (FSC 5962) should contact DSCC-VA, telephone (614) 692-0544.

6.5 Comments. Comments on this drawing should be directed to DSCC-VA, Columbus, Ohio 43218-3990, or telephone (614) 692-0547.

6.6 Approved sources of supply. Approved sources of supply are listed in MIL-HDBK-103. The vendors listed in MIL-HDBK-103 have agreed to this drawing and a certificate of compliance (see 3.6 herein) has been submitted to and accepted by DSCC-VA.

STANDARD MICROCIRCUIT DRAWING DEFENSE SUPPLY CENTER COLUMBUS COLUMBUS, OHIO 43218-3990	SIZE A		5962-87661
		REVISION LEVEL G	SHEET 11

STANDARD MICROCIRCUIT DRAWING BULLETIN

DATE: 09-03-30

Approved sources of supply for SMD 5962-87661 are listed below for immediate acquisition information only and shall be added to MIL-HDBK-103 and QML-38535 during the next revision. MIL-HDBK-103 and QML-38535 will be revised to include the addition or deletion of sources. The vendors listed below have agreed to this drawing and a certificate of compliance has been submitted to and accepted by DSCC-VA. This information bulletin is superseded by the next dated revision of MIL-HDBK-103 and QML-38535. DSCC maintains an online database of all current sources of supply at <http://www.dscclia.mil/Programs/Smcr/>.

Standard microcircuit drawing PIN <u>1/</u>	Vendor CAGE number	Vendor similar PIN <u>2/</u>
5962-8766101XA	<u>3/</u> <u>3/</u> 0C7V7	AM27C128-90/BXA WS27C128F-90DMB 27C128-90
5962-8766101YA	<u>3/</u> <u>3/</u> 0C7V7	AM27C128-90/BUA WS27C128F-90CMB 27C128-90
5962-8766102XA	<u>3/</u> <u>3/</u> 0C7V7	AM27C128-120/BXA WS27C128L-12DMB 27C128-120
5962-8766102YA	<u>3/</u> <u>3/</u> 0C7V7	AM27C128-120/BUA WS27C128L-12CMB 27C128-120
5962-8766103XA	<u>3/</u> <u>3/</u> <u>3/</u> 0C7V7	AM27C128-150/BXA 27C128-15BXA WS27C128L-15DMB 27C128-150
5962-8766103YA	<u>3/</u> <u>3/</u> <u>3/</u> 0C7V7	AM27C128-150/BUA 27C128-15BUC WS27C128L-15CMB 27C128-150
5962-8766104XA	<u>3/</u> <u>3/</u> <u>3/</u> 0C7V7	AM27C128-170/BXA 27C128-17BXA WS27C128L-17DMB 27C128-170
5962-8766104YA	<u>3/</u> <u>3/</u> <u>3/</u> 0C7V7	AM27C128-170/BUA 27C128-17BUC WS27C128L-17CMB 27C128-170
5962-8766105XA	<u>3/</u> <u>3/</u> <u>3/</u> <u>3/</u> 0C7V7	SMJ27C128-20JM AM27C128-200/BXA MD27C128-20 27C128-20BXA WS27C128L-20DMB 27C128-200
5962-8766105YA	<u>3/</u> <u>3/</u> <u>3/</u> 0C7V7	AM27C128-200/BUA 27C128-20BUC WS27C128L-20CMB 27C128-200

See footnotes at end of table.

STANDARD MICROCIRCUIT DRAWING BULLETIN – Continued.

Standard microcircuit drawing PIN <u>1/</u>	Vendor CAGE number	Vendor similar PIN <u>2/</u>
5962-8766106XA	<u>3/</u> <u>3/</u> <u>3/</u> <u>3/</u> 0C7V7	SMJ27C128-25JM AM27C128-250/BXA WS27C128L-25DMB 27C128-25BXA 27C128-250
5962-8766106YA	<u>3/</u> <u>3/</u> <u>3/</u> 0C7V7	AM27C128-250/BUA WS27C128L-25CMB 27C128-25BUC 27C128-250
5962-8766107XA	<u>3/</u> <u>3/</u> <u>3/</u> <u>3/</u> 0C7V7	SMJ27C128-30JM AM27C128-300/BXA WS27C128L-30DMB 27C128-30BXA 27C128-300/BXA
5962-8766107YA	<u>3/</u> <u>3/</u> <u>3/</u> 0C7V7	AM27C128-300/BUA WS27C128L-30CMB 27C128-30BUC 27C128-300
5962-8766108XA	0C7V7 0C7V7	WS57C128FB-70DMB 27C128-70
5962-8766108YA	0C7V7 0C7V7	WS57C128FB-70CMB 27C128-70

1/ The lead finish shown for each PIN representing a hermetic package is the most readily available from the manufacturer listed for that part. If the desired lead finish is not listed, contact the Vendor to determine its availability.

2/ Caution: Do not use this number for item acquisition. Items acquired to this number may not satisfy the performance requirements of this drawing.

3/ Not available from an approved source.

<u>Vendor CAGE number</u>	<u>Vendor name and address</u>	<u>Manufacturing code</u>	<u>Device code</u>
0C7V7	QP Semiconductor 2945 Oakmead Village Court Santa Clara, CA 95051	01H	16H

The information contained herein is disseminated for convenience only and the Government assumes no liability whatsoever for any inaccuracies in the information bulletin.

X-ON Electronics

Largest Supplier of Electrical and Electronic Components

Click to view similar products for [EPROM](#) category:

Click to view products by [E2v](#) manufacturer:

Other Similar products are found below :

[QP27C256L-120/XIA](#) [8510204YA](#) [8510201YA](#) [5962-8606305YA](#) [5962-8606306XA](#) [5962-8606317XA](#) [5962-8680503QA](#) [5962-87515053A](#)
[5962-8961412MXA](#) [5962-8981703XA](#) [M38510/20904BJA](#) [M38510/20802BJA](#) [5962-9080308MKA](#) [5962-8961405MYA](#) [5962-](#)
[8961402MXA](#) [5962-8851805LA](#) [5962-8766107XA](#) [5962-8764804YA](#) [5962-8764802YA](#) [5962-8680505QA](#) [5962-8606310UA](#) [5962-](#)
[8606309XA](#) [5962-8606304XA](#) [DS2502PU-1176+](#) [DS2502G+U](#) [AT27C040-90PU](#) [AT27C256R-70PU](#) [AT27C4096-90JU](#) [AT27LV256A-](#)
[90JU](#) [QP7C271-45WC](#) [8510203ZA](#) [5962-87515073A](#) [AT27C512R-70JU](#) [DS2505+T&R](#) [DS2505PT&R](#) [DS2502+T&R](#) [AT27LV020A-](#)
[12JU-T](#) [AT27C010-70PU](#) [AT27C040-90JU](#) [DS2505P+T&R](#) [DS2502P+T&R](#) [AT27C040-90JU-T](#) [AT28HC256F-90JU-T](#) [AT28HC256-90JU-](#)
[T](#) [AT27C010-70JU](#) [AT27C020-90JU](#) [AT27LV010A-70JU](#) [AT27C080-90PU](#) [AT27BV010-90JU](#) [AT27BV1024-90JU](#)