

REVISIONS

LTR	DESCRIPTION	DATE (YR-MO-DA)	APPROVED
D	Redrawn with changes made under NOR No. 5962-R116-92 Revision B and NOR No. 5962-R004-93 Revision C. Added vendor CAGE numbers 65896 and OK6N4 to the drawing as sources of supply. Added device types 10UX, 10YX, 11UX, 11YX, and 12UX, 12YX. Removed vendor CAGE number OBYV4 from drawing as approved source of supply. Removed vendor CAGE number 61772 as approved source of supply for devices 01ZX, 02ZX, 03ZX, 05XX, 05YX, 05ZX, 05UX, 06ZX, 07XX, 07YX, 07ZX, 07UX, 08XX, 08YX, 08ZX, 08UX, 09XX, 09YX, 09ZX, and 09UX. Added vendor CAGE 61772 as a source of supply for devices 01MX, 01NX, 02MX, 02NX, 03MX, 03NX, 04NX, 04MX, 06MX, and 06NX. Remove vendor CAGE 34649 as a source of supply for devices 02XX, 02YX, 04XX, and 04YX. Editorial changes throughout.	94 - 01 - 04	M. A. Frye
E	Drawing updated to reflect current requirements. Editorial changes throughout. - gap	00 - 10 - 12	Raymond Monnin
F	Added device to cover 12 ns access time. Updated boilerplate, editorial changes throughout. ksr	02 - 08 - 16	Raymond Monnin
G	Boilerplate update and part of five year review. tcr	07 - 11 - 01	Robert M. Heber

THE FRONT PAGE OF THIS DRAWING HAS BEEN REPLACED

REV																			
SHEET																			
REV	G	G	G																
SHEET	15	16	17																
REV STATUS OF SHEETS	REV			G	G	G	G	G	G	G	G	G	G	G	G	G	G	G	
	SHEET			1	2	3	4	5	6	7	8	9	10	11	12	13	14		
PMIC N/A	PREPARED BY Kenneth Rice			<p align="center">DEFENSE SUPPLY CENTER COLUMBUS COLUMBUS, OHIO 43218-3990 http://www.dscclia.mil</p> <p>MICROCIRCUIT, MEMORY, DIGITAL, CMOS, 32K X 8 STATIC RANDOM ACCESS MEMORY (SRAM) LOW POWER, MONOLITHIC SILICON</p>															
<p align="center">STANDARD MICROCIRCUIT DRAWING</p> <p>THIS DRAWING IS AVAILABLE FOR USE BY ALL DEPARTMENTS AND AGENCIES OF THE DEPARTMENT OF DEFENSE</p> <p align="center">AMSC N/A</p>	CHECKED BY Ray Monnin																		
	APPROVED BY Michael A. Frye																		
	DRAWING APPROVAL DATE 88-06-03																		
	REVISION LEVEL G			SIZE A	CAGE CODE 67268	5962-88552													
				SHEET		1 OF 17													

1. SCOPE

1.1 Scope. This drawing describes device requirements for MIL-STD-883 compliant, non-JAN class level B microcircuits in accordance with MIL-PRF-38535, appendix A.

1.2 Part or Identifying Number (PIN). The complete PIN is as shown in the following example:

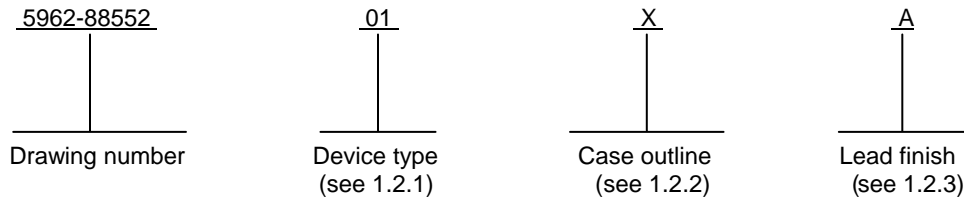

1.2.1 Device type(s). The device type(s) identify the circuit function as follows:

<u>Device type</u>	<u>Generic number</u> ^{1/}	<u>Circuit function</u>	<u>Access time</u>
01		32K x 8 low power CMOS SRAM	100 ns
02, 07			70 ns
03, 08			55 ns
04, 09			45 ns
05			35 ns
06			25 ns
10			20 ns
11			17 ns
12			15 ns
13			12 ns

1.2.2 Case outline(s). The case outline(s) are as designated in MIL-STD-1835 and as follows:

<u>Outline letter</u>	<u>Descriptive designator</u>	<u>Terminals</u>	<u>Package style</u>
X	GDIP1-T28 or CDIP2-T28	28	Dual-in-line
Y	CQCC1-N32	32	Rectangular leadless chip carrier
Z	CDFP3-F28	28	Flat pack
U	CDIP3-T28 or GDIP4-T28	28	Dual-in-line
T	CDFP4-T28	28	Flat pack
M	CQCC3-N28	28	Rectangular leadless chip carrier
N	GDFP2-F28	28	Flat pack

1.2.3 Lead finish. The lead finish is as specified in MIL-PRF-38535, appendix A.

1.3 Absolute maximum ratings.

Supply voltage range (V_{CC})	-0.5 V dc to +7.0 V dc ^{2/}
Input voltage range	-0.5 V dc to +6.0 V dc
Storage temperature range	-65°C to +150°C
Thermal resistance, junction-to-case (θ_{JC})	See MIL-STD-1835
Junction temperature (T_J)	+150°C ^{3/}
Power dissipation (P_D)	1.0 W
Junction temperature (soldering, 10 seconds)	+260°C

- ^{1/} Generic numbers are listed on the Standard Microcircuit Drawing Source Approval Bulletin at the end of this document and will also be listed in MIL-HDBK-103.
- ^{2/} All voltages referenced to V_{CC} .
- ^{3/} Maximum junction temperature shall not be exceeded except for allowable short duration burn-in screening conditions in accordance with method 5004 of MIL-STD-883.

STANDARD MICROCIRCUIT DRAWING DEFENSE SUPPLY CENTER COLUMBUS COLUMBUS, OHIO 43218-3990	SIZE A		5962-88552
		REVISION LEVEL G	SHEET 2

1.4 Recommended operating conditions.

Supply voltage range (V_{CC}).....	+4.5 V dc to +5.5 V dc <u>4/</u>
Ground voltage (V_{SS}).....	0 V dc
Input high voltage (V_{IH}).....	+2.2 V dc to $V_{CC} + 0.5$ V dc
Input low voltage (V_{IL}).....	-0.5 V dc to 0.8 V dc
Case operating temperature (T_C).....	-55°C to +125°C

2. APPLICABLE DOCUMENTS

2.1 Government specification, standards, and handbooks. The following specification, standards, and handbooks form a part of this drawing to the extent specified herein. Unless otherwise specified, the issues of these documents are those cited in the solicitation or contract.

DEPARTMENT OF DEFENSE SPECIFICATION

MIL-PRF-38535 - Integrated Circuits, Manufacturing, General Specification for.

DEPARTMENT OF DEFENSE STANDARDS

MIL-STD-883 - Test Method Standard Microcircuits.
 MIL-STD-1835 - Interface Standard Electronic Component Case Outlines.

DEPARTMENT OF DEFENSE HANDBOOKS

MIL-HDBK-103 - List of Standard Microcircuit Drawings.
 MIL-HDBK-780 - Standard Microcircuit Drawings.

(Copies of these documents are available online at <http://assist.daps.dla.mil/quicksearch/> or <http://assist.daps.dla.mil> or from the Standardization Document Order Desk, 700 Robbins Avenue, Building 4D, Philadelphia, PA 19111-5094.)

2.2 Order of precedence. In the event of a conflict between the text of this drawing and the references cited herein, the text of this drawing takes precedence. Nothing in this document, however, supersedes applicable laws and regulations unless a specific exemption has been obtained.

4/ All voltages referenced to V_{CC} .

STANDARD MICROCIRCUIT DRAWING DEFENSE SUPPLY CENTER COLUMBUS COLUMBUS, OHIO 43218-3990	SIZE A		5962-88552
		REVISION LEVEL G	SHEET 3

3. REQUIREMENTS

3.1 Item requirements. The individual item requirements shall be in accordance with MIL-PRF-38535, appendix A for non-JAN class level B devices and as specified herein. Product built to this drawing that is produced by a Qualified Manufacturer Listing (QML) certified and qualified manufacturer or a manufacturer who has been granted transitional certification to MIL-PRF-38535 may be processed as QML product in accordance with the manufacturers approved program plan and qualifying activity approval in accordance with MIL-PRF-38535. This QML flow as documented in the Quality Management (QM) plan may make modifications to the requirements herein. These modifications shall not affect form, fit, or function of the device. These modifications shall not affect the PIN as described herein. A "Q" or "QML" certification mark in accordance with MIL-PRF-38535 is required to identify when the QML flow option is used.

3.2 Design, construction, and physical dimensions. The design, construction, and physical dimensions shall be as specified in MIL-PRF-38535, appendix A and herein.

3.2.1 Case outlines. The case outlines shall be in accordance with 1.2.2 herein.

3.2.2 Terminal connections. The terminal connections shall be as specified on figure 1.

3.2.3 Truth tables. The truth tables shall be as specified on figure 2.

3.3 Electrical performance characteristics. Unless otherwise specified herein, the electrical performance characteristics are as specified in table I and shall apply over the full case operating temperature range.

3.4 Electrical test requirements. The electrical test requirements shall be the subgroups specified in table II. The electrical tests for each subgroup are described in table I.

3.5 Marking. Marking shall be in accordance with MIL-PRF-38535, appendix A. The part shall be marked with the PIN listed in 1.2 herein. In addition, the manufacturer's PIN may also be marked. For packages where marking of the entire SMD PIN number is not feasible due to space limitations, the manufacturer has the option of not marking the "5962-" on the device.

3.5.1 Certification/compliance mark. A compliance indicator "C" shall be marked on all non-JAN devices built in compliance to MIL-PRF-38535, appendix A. The compliance indicator "C" shall be replaced with a "Q" or "QML" certification mark in accordance with MIL-PRF-38535 to identify when the QML flow option is used.

3.6 Certificate of compliance. A certificate of compliance shall be required from a manufacturer in order to be listed as an approved source of supply in MIL-HDBK-103 (see 6.6 herein). The certificate of compliance submitted to DSCC-VA prior to listing as an approved source of supply shall affirm that the manufacturer's product meets the requirements of MIL-PRF-38535, appendix A and the requirements herein.

3.7 Certificate of conformance. A certificate of conformance as required in MIL-PRF-38535, appendix A shall be provided with each lot of microcircuits delivered to this drawing.

3.8 Notification of change. Notification of change to DSCC-VA shall be for any change that affects this drawing.

3.9 Verification and review. DSCC, DSCC's agent, and the acquiring activity retain the option to review the manufacturer's facility and applicable required documentation. Offshore documentation shall be made available onshore at the option of the reviewer.

STANDARD MICROCIRCUIT DRAWING DEFENSE SUPPLY CENTER COLUMBUS COLUMBUS, OHIO 43218-3990	SIZE A		5962-88552
		REVISION LEVEL G	SHEET 4

Table I. Electrical performance characteristics.

Test	Symbol	Conditions -55°C ≤ T _C ≤ +125°C V _{SS} = 0 V, 4.5 V ≤ V _{CC} ≤ 5.5 V unless otherwise specified	Group A subgroups	Device type	Limits		Unit
					Min	Max	
Input leakage current	I _{LI}	V _{CC} = max, V _{IN} = GND to V _{CC}	1, 2, 3	All		10	μA
Output leakage current	I _{LO}	V _{CC} = max, V _{OUT} = GND to V _{CC} $\overline{CE} \geq V_{IH}; \overline{WE} \leq V_{IL}$	1, 2, 3	All		10	μA
Output low voltage	V _{OL}	V _{CC} = 4.5 V, I _{OL} = 8 mA, V _{IL} = 0.8 V, V _{IH} = 2.2 V	1, 2, 3	All		0.4	V
Output high voltage	V _{OH}	V _{CC} = 4.5 V, I _{OH} = -4 mA, V _{IL} = 0.8 V, V _{IH} = 2.2 V	1, 2, 3	All	2.4		V
Data retention voltage	V _{DR}		1, 2, 3	All	2.0		V
Operating supply current (active)	I _{CC1}	V _{CC} = 5.5 V, f = f max 1/ $\overline{CE} = V_{IL}$, outputs open, all other inputs at V _{IL}	1, 2, 3	01, 02, 07, 13		100	mA
				03, 08		125	
				04, 09		135	
				05		145	
				06, 11		155	
				10		150	
				12		160	
Standby power supply current (TTL)	I _{CC2}	$\overline{CE} \geq V_{IH}$, outputs open V _{CC} = 5.5 V, f = 0 MHz	1, 2, 3	01-04		3	mA
				05-09, 13		5	
				10-12		10	
Standby power supply current (CMOS)	I _{CC3}	$\overline{CE} \geq (V_{CC}-0.2 V)$, f = 0 MHz, outputs open, V _{CC} = 5.5 V all other inputs ≤ 0.2 V or ≥ (V _{CC} -0.2 V)	1, 2, 3	05, 07-09, 13		900	μA
				01-04, 06		1.5	mA
				10-12		5	
Data retention current	I _{CC4} 2/	V _{CC} = 3.0 V, $\overline{CE} \geq (V_{CC}-0.2 V)$, f = 0 MHz, outputs open, all other inputs ≤ 0.2 V or ≥ (V _{CC} -0.2 V)	1, 2, 3	05, 07-09, 13		350	μA
				01-04, 06		800	
				10-12		750	
Input capacitance	C _I 2/	V _I = 5.0 V or GND, f = 1 MHz, T _C = +25°C, See 4.3.1c	4	All		12	pF
Output capacitance	C _O 2/	V _O = 5.0 V or GND, f = 1 MHz, T _C = +25°C, See 4.3.1c	4	All		12	pF

See footnotes at end of table.

STANDARD MICROCIRCUIT DRAWING DEFENSE SUPPLY CENTER COLUMBUS COLUMBUS, OHIO 43218-3990	SIZE A		5962-88552
		REVISION LEVEL G	SHEET 5

Table I. Electrical performance characteristics - Continued.

Test	Symbol	Conditions -55°C ≤ T _C ≤ +125°C V _{SS} = 0 V, 4.5 V ≤ V _{CC} ≤ 5.5 V unless otherwise specified	Group A subgroups	Device type	Limits		Unit
					Min	Max	
Read cycle time	t _{AVAV}	3/	9, 10, 11	01	100		ns
				02, 07	70		
				03, 08	55		
				04, 09	45		
				05	35		
				06	25		
				10	20		
				11	17		
				12	15		
				13	12		
Address access time	t _{AVQV}		9, 10, 11	01		100	ns
				02, 07		70	
				03, 08		55	
				04, 09		45	
				05		35	
				06		25	
				10		20	
				11		17	
				12		15	
				13		12	
Chip-enable access time	t _{ELQV}		9, 10, 11	01		100	ns
				02, 07		70	
				03, 08		55	
				04, 09		45	
				05		35	
				06		25	
				10		20	
				11		17	
				12		15	
				13		12	
Output hold from address change	t _{AVQX}		9, 10, 11	01-12	3		ns
				13	2		
Output enable to output valid	t _{OLQV}		9, 10, 11	01		60	ns
				02-04, 07-09		35	
				05, 06		20	
				10, 11		10	
				12		8	
				13		6	

See footnotes at end of table.

STANDARD MICROCIRCUIT DRAWING DEFENSE SUPPLY CENTER COLUMBUS COLUMBUS, OHIO 43218-3990	SIZE A		5962-88552
		REVISION LEVEL G	SHEET 6

Table I. Electrical performance characteristics - Continued.

Test	Symbol	Conditions -55°C ≤ T _C ≤ +125°C V _{SS} = 0 V, 4.5 V ≤ V _{CC} ≤ 5.5 V unless otherwise specified	Group A subgroups	Device type	Limits		Unit
					Min	Max	
Chip select to output in low Z	t _{ELQX} <u>2/</u> , <u>4/</u>	<u>3/</u>	9, 10, 11	01-12	3		ns
				13	2		
Chip deselect to output in high Z	t _{EHQZ} <u>2/</u> , <u>4/</u>		9, 10, 11	01-04, 07, 09		35	ns
				05, 06		20	
				10-12		10	
				13		7	
Output disable to output in high Z	t _{OHQZ} <u>2/</u> , <u>4/</u>		9, 10, 11	01-04, 07, 09		35	ns
				05, 06		20	
				10-12		10	
				13		7	
Write enable to output in high Z	t _{WLQZ} <u>2/</u> , <u>4/</u>		9, 10, 11	01		50	ns
				02-04, 07-09		35	
				05, 06		20	
				10-12		10	
				13		7	
Output enable to output in low Z	t _{OLQX} <u>2/</u> , <u>4/</u>		9, 10, 11	All	0		ns
Retention time	t _{CDR}	CE ≥ V _{CC} -0.2 V	9, 10, 11	All	0		ns
Operation recovery time	t _R <u>2/</u>	CE ≥ V _{CC} -0.2 V	9, 10, 11	All	t _{AVAV}		ns
Data valid to end of write	t _{DVWH} t _{DVEH}		9, 10, 11	01-04, 07-09	35		ns
				05, 06	15		
				10-12	10		
				13	8		
Data hold time	t _{WHDX} t _{EHDX}		9, 10, 11	01-09	3		ns
				10-13	0		
Output active from end of write	t _{WHQX} <u>2/</u> , <u>4/</u>		9, 10, 11	01-09	3		ns
				10-13	0		
Write cycle time	t _{AVAV}		9, 10, 11	01	100		ns
				02, 07	70		
				03, 08	55		
				04, 09	45		
				05	35		
				06	25		
				10, 11	20		
				12	15		
			13	12			

See footnotes at end of table.

STANDARD MICROCIRCUIT DRAWING DEFENSE SUPPLY CENTER COLUMBUS COLUMBUS, OHIO 43218-3990	SIZE A		5962-88552
		REVISION LEVEL G	SHEET 7

Table I. Electrical performance characteristics - Continued.

Test	Symbol	Conditions -55°C ≤ T _C ≤ +125°C V _{SS} = 0 V, 4.5 V ≤ V _{CC} ≤ 5.5 V unless otherwise specified	Group A subgroups	Device type	Limits		Unit
					Min	Max	
Chip select to end of write	t _{ELWH}	3/	9, 10, 11	01	90		ns
				02, 07	60		
				03, 08	50		
				04, 09	40		
				05	30		
				06	20		
				10, 11	15		
				12	12		
				13	10		
Address valid to end of write	t _{AVWH}		9, 10, 11	01	85		ns
				02, 07	60		
				03, 08	50		
				04, 09	40		
				05	30		
				06	20		
				10, 11	15		
				12	12		
				13	10		
Address-setup time	t _{AVEL} t _{AVWL}		9, 10, 11	All	0		ns
Write pulse width	t _{WLWH}		9, 10, 11	01	55		ns
				02, 07	45		
				03, 08	40		
				04, 09	35		
				05	30		
				06	25		
				10, 11	15		
				12	12		
				13	9		
Write recovery time	t _{WHAX} t _{EHAX}		9, 10, 11	01-09	7		ns
				10-13	0		

1/ f max = 1/t_{AVAV}.

2/ This parameter tested initially and after any design or process change which could affect this parameter, and therefore shall be guaranteed to the limits specified in table I.

3/ For output load circuits see figure 3 and for timing waveforms see figure 4.

4/ Transition is measured ±500 mV from steady state voltage.

STANDARD MICROCIRCUIT DRAWING DEFENSE SUPPLY CENTER COLUMBUS COLUMBUS, OHIO 43218-3990	SIZE A		5962-88552
		REVISION LEVEL G	SHEET 8

All device types		
Case outlines	X, Z, U, T, M, and N	Y
Terminal numbers	Terminal symbol	
1	A ₁₄	NC
2	A ₁₂	A ₁₄
3	A ₇	A ₁₂
4	A ₆	A ₇
5	A ₅	A ₆
6	A ₄	A ₅
7	A ₃	A ₄
8	A ₂	A ₃
9	A ₁	A ₂
10	A ₀	A ₁
11	I/O ₁	A ₀
12	I/O ₂	NC
13	I/O ₃	I/O ₁
14	GND	I/O ₂
15	I/O ₄	I/O ₃
16	I/O ₅	GND
17	I/O ₆	NC
18	I/O ₇	I/O ₄
19	I/O ₈	I/O ₅
20	\overline{CE}	I/O ₆
21	A ₁₀	I/O ₇
22	\overline{OE}	I/O ₈
23	A ₁₁	\overline{CE}
24	A ₉	A ₁₀
25	A ₈	\overline{OE}
26	A ₁₃	NC
27	\overline{WE}	A ₁₁
28	V _{CC}	A ₉
29	---	A ₈
30	---	A ₁₃
31	---	\overline{WE}
32	---	V _{CC}

NC = No connection

FIGURE 1. Terminal connections.

STANDARD MICROCIRCUIT DRAWING DEFENSE SUPPLY CENTER COLUMBUS COLUMBUS, OHIO 43218-3990	SIZE A		5962-88552
		REVISION LEVEL G	SHEET 9

\overline{CE}	\overline{WE}	\overline{OE}	I/O	Function
H	X	X	High Z	Standby (I_{CC2})
$\geq V_{CC} - 0.2 V$	X	X	High Z	Standby (I_{CC3})
L	H	H	High Z	Output disable
L	H	L	Data out	Read
L	L	X	Data in	Write

FIGURE 2. Truth table.

STANDARD MICROCIRCUIT DRAWING DEFENSE SUPPLY CENTER COLUMBUS COLUMBUS, OHIO 43218-3990	SIZE A		5962-88552
		REVISION LEVEL G	SHEET 10

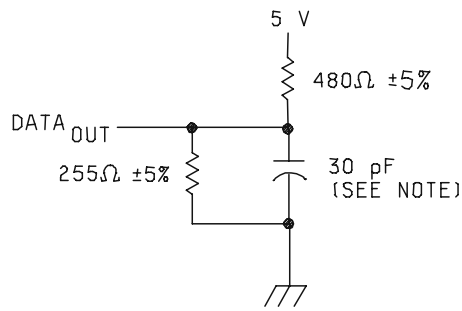

CIRCUIT A
OUTPUT LOAD

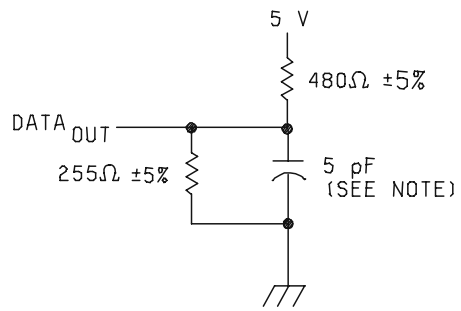

CIRCUIT B
(FOR t_{OLQX} , t_{ELQX} , t_{DHQZ} ,
 t_{WLQZ} , t_{EHQZ} , t_{WHQX})

NOTE: Including scope and jig.
(minimum values)

AC test conditions

Input pulse levels	GND to 3.0 V
Input rise fall times	5 ns
Input timing reference levels	1.5 V
Output reference levels	1.5 V

FIGURE 3. Output load circuit.

**STANDARD
MICROCIRCUIT DRAWING**
**DEFENSE SUPPLY CENTER COLUMBUS
COLUMBUS, OHIO 43218-3990**

SIZE
A

5962-88552

REVISION LEVEL
G

SHEET

11

Timing waveform of read cycle number 1 (see note 1)

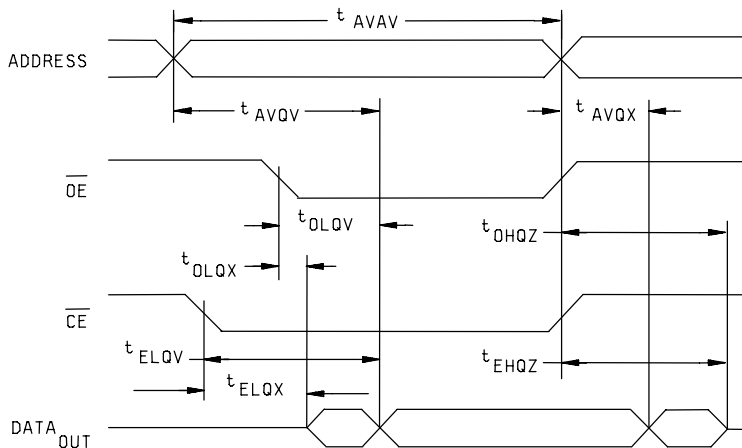

Timing waveform of read cycle number 2 (see notes 1, 2, and 4)

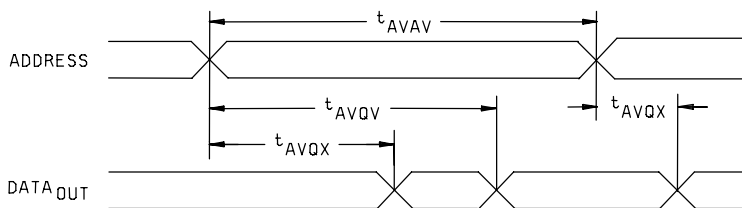

Timing waveform of read cycle number 3 (see notes 1, 3, and 4)

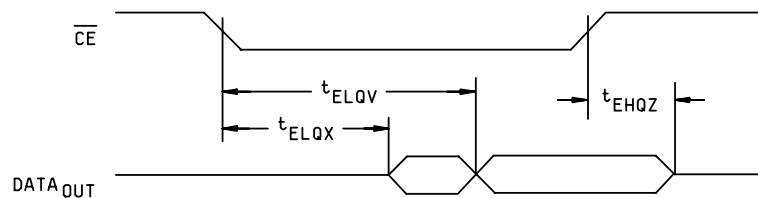

NOTES:

1. \overline{WE} is high for read cycle.
2. Device is continuously selected. $\overline{CE} = V_{IL}$.
3. Address valid prior to or coincident with \overline{CE} transition low.
4. $\overline{OE} - V_{IL}$.
5. Transition is measured ± 500 mV from steady state with 5 pF load (including scope and jig).

FIGURE 4. Timing waveforms.

STANDARD MICROCIRCUIT DRAWING DEFENSE SUPPLY CENTER COLUMBUS COLUMBUS, OHIO 43218-3990	SIZE A		5962-88552
		REVISION LEVEL G	SHEET 12

Timing waveform of write cycle number 1 (\overline{WE} controlled timing) (see notes 1, 2, 3, 6, and 7)

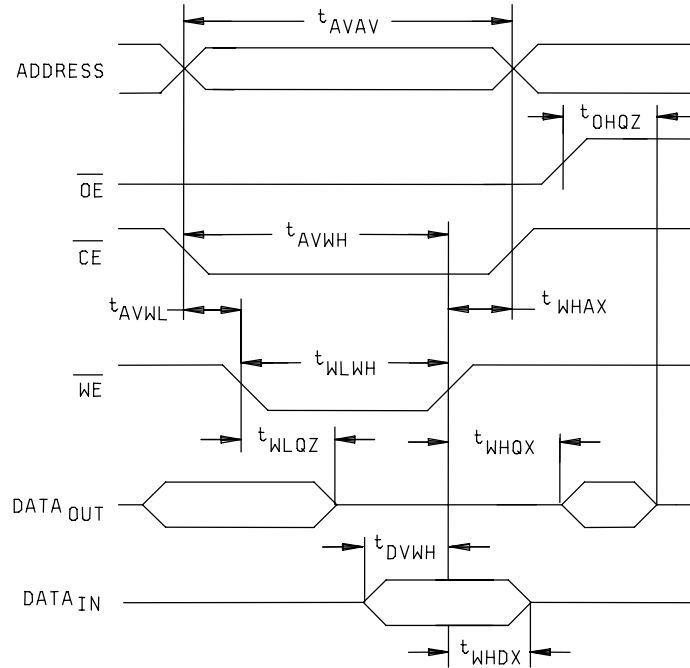

Timing waveform of write cycle number 2 (\overline{CE} controlled timing) (see notes 1, 2, 3, and 5)

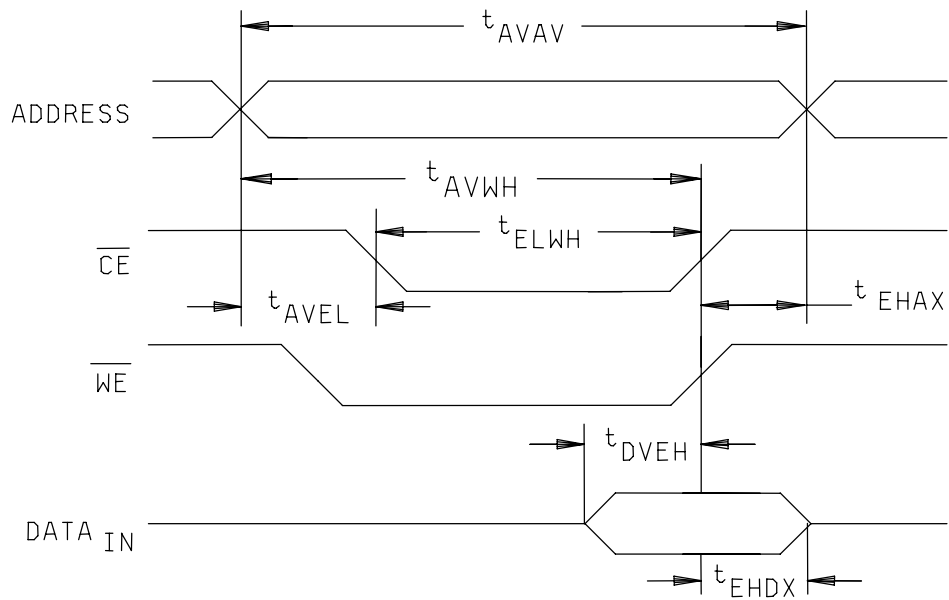

FIGURE 4. Timing waveforms - Continued.

STANDARD MICROCIRCUIT DRAWING DEFENSE SUPPLY CENTER COLUMBUS COLUMBUS, OHIO 43218-3990	SIZE A		5962-88552
		REVISION LEVEL G	SHEET 13

NOTES:

1. \overline{WE} must be high during all address transitions.
2. A write occurs during the overlap (t_{ELWH} or t_{WLWH}) of a low \overline{CE} and a low \overline{WE} .
3. t_{WHAX} is measured from the earlier of \overline{CE} or \overline{WE} going high to the end of the write cycle.
4. During this period, the I/O pins are in the output state, and input signals must not be applied.
5. If the \overline{CE} low transition occurs simultaneously with or after the \overline{WE} low transition, the outputs remain in the high impedance state.
6. Transition is measured ± 500 mV from steady state with a 5 pF load (including scope and jig).
7. If \overline{OE} is low during a \overline{WE} controlled write cycle, the write pulse width must be the larger of t_{WLWH} or ($t_{WLQZ} + t_{DVWH}$) to allow the I/O drivers to turn off and data to be placed on the bus for required t_{DVWH} . If \overline{OE} is high during a \overline{WE} controlled write cycle, this requirement does not apply and the write pulse can be as short as the specified t_{WLWH} .

FIGURE 4. Timing waveforms - Continued.

STANDARD MICROCIRCUIT DRAWING DEFENSE SUPPLY CENTER COLUMBUS COLUMBUS, OHIO 43218-3990	SIZE A		5962-88552
		REVISION LEVEL G	SHEET 14

Low V_{CC} retention waveform

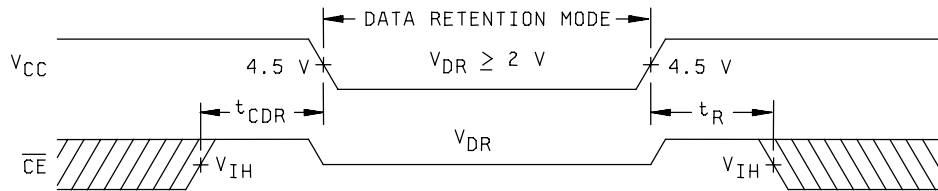

FIGURE 4. Timing waveforms - Continued.

STANDARD MICROCIRCUIT DRAWING DEFENSE SUPPLY CENTER COLUMBUS COLUMBUS, OHIO 43218-3990	SIZE A		5962-88552
		REVISION LEVEL G	SHEET 15

4. VERIFICATION

4.1 Sampling and inspection. Sampling and inspection procedures shall be in accordance with MIL-PRF-38535, appendix A.

4.2 Screening. Screening shall be in accordance with method 5004 of MIL-STD-883, and shall be conducted on all devices prior to quality conformance inspection. The following additional criteria shall apply:

- a. Burn-in test, method 1015 of MIL-STD-883.
 - (1) Test condition C or D. The test circuit shall be maintained by the manufacturer under document revision level control and shall be made available to the preparing or acquiring activity upon request. The test circuit shall specify the inputs, outputs, biases, and power dissipation, as applicable, in accordance with the intent specified in method 1015 of MIL-STD-883.
 - (2) $T_A = +125^{\circ}\text{C}$, minimum.
- b. Interim and final electrical test parameters shall be as specified in table II herein, except interim electrical parameter tests prior to burn-in are optional at the discretion of the manufacturer.

TABLE II. Electrical test requirements.

MIL-STD-883 test requirements	Subgroups (in accordance with MIL-STD-883, method 5005, table I)
Interim electrical parameters (method 5004)	
Final electrical test parameters (method 5004)	1*, 2, 3, 7*, 8A, 8B, 9, 10, 11
Group A test requirements (method 5005)	1, 2, 3, 4**, 7***, (8A, 8B)***, 9, 10, 11
Groups C and D end-point electrical parameters (method 5005)	2, 3, 7, 8A, 8B

* PDA applies to subgroup 1 and 7.
 ** See 4.3.1c.
 *** See 4.3.1d.

4.3 Quality conformance inspection. Quality conformance inspection shall be in accordance with method 5005 of MIL-STD-883 including groups A, B, C, and D inspections. The following additional criteria shall apply.

4.3.1 Group A inspection.

- a. Tests shall be as specified in table II herein.
- b. Subgroups 5 and 6 in table I, method 5005 of MIL-STD-883 shall be omitted.
- c. Subgroup 4 (C_I and C_O measurement) shall be measured only for the initial test and after process or design changes which may affect input capacitance.
- d. Subgroups 7, 8A and 8B shall include verification of the truth table.

STANDARD MICROCIRCUIT DRAWING DEFENSE SUPPLY CENTER COLUMBUS COLUMBUS, OHIO 43218-3990	SIZE A		5962-88552
		REVISION LEVEL G	SHEET 16

4.3.2 Groups C and D inspections.

- a. End-point electrical parameters shall be as specified in table II herein.
- b. Steady-state life test conditions, method 1005 of MIL-STD-883.
 - (1) Test condition C or D. The test circuit shall be maintained by the manufacturer under document revision level control and shall be made available to the preparing or acquiring activity upon request. The test circuit shall specify the inputs, outputs, biases, and power dissipation, as applicable, in accordance with the intent specified in method 1005 of MIL-STD-883.
 - (2) $T_A = +125^{\circ}\text{C}$, minimum.
 - (3) Test duration: 1,000 hours, except as permitted by method 1005 of MIL-STD-883.

5. PACKAGING

5.1 Packaging requirements. The requirements for packaging shall be in accordance with MIL-PRF-38535, appendix A.

6. NOTES

6.1 Intended use. Microcircuits conforming to this drawing are intended for use for Government microcircuit applications (original equipment), design applications, and logistics purposes.

6.2 Replaceability. Microcircuits covered by this drawing will replace the same generic device covered by a contractor-prepared specification or drawing.

6.3 Configuration control of SMD's. All proposed changes to existing SMD's will be coordinated with the users of record for the individual documents. This coordination will be accomplished using DD Form 1692, Engineering Change Proposal.

6.4 Record of users. Military and industrial users shall inform Defense Supply Center Columbus (DSCC) when a system application requires configuration control and the applicable SMD. DSCC will maintain a record of users and this list will be used for coordination and distribution of changes to the drawings. Users of drawings covering microelectronics devices (FSC 5962) should contact DSCC-VA, telephone (614) 692-0544.

6.5 Comments. Comments on this drawing should be directed to DSCC-VA, Columbus, Ohio 43218-3990, or telephone (614) 692-0547.

6.6 Approved sources of supply. Approved sources of supply are listed in MIL-HDBK-103. The vendors listed in MIL-HDBK-103 have agreed to this drawing and a certificate of compliance (see 3.6 herein) has been submitted to and accepted by DSCC-VA.

STANDARD MICROCIRCUIT DRAWING DEFENSE SUPPLY CENTER COLUMBUS COLUMBUS, OHIO 43218-3990	SIZE A		5962-88552
		REVISION LEVEL G	SHEET 17

STANDARD MICROCIRCUIT DRAWING BULLETIN

DATE: 07 – 11 – 01

Approved sources of supply for SMD 5962-88552 are listed below for immediate acquisition information only and shall be added to MIL-HDBK-103 and QML-38535 during the next revision. MIL-HDBK-103 and QML-38535 will be revised to include the addition or deletion of sources. The vendors listed below have agreed to this drawing and a certificate of compliance has been submitted to and accepted by DSCC-VA. This information bulletin is superseded by the next dated revision of MIL-HDBK-103 and QML-38535. DSCC maintains an online database of all current sources of supply at <http://www.dscclia.mil/Programs/Smcr/>.

Standard microcircuit drawing PIN <u>1</u> /	Vendor CAGE number	Vendor similar PIN <u>2</u> /
5962-8855201MA	3DTT2	P4C1256L-100L28MB
	<u>3</u> /	IDT71256L100L28B
5962-8855201NA	0C7V7	QP7C199L-100KMB
	3DTT2	P4C1256L-100FMB
	<u>3</u> /	IDT71256L100XEB
5962-8855201UA	61772	IDT71256L100TDB
	0C7V7	QP7C199L-100DMB
	3DTT2	P4C1256L-100CMB
5962-8855201XA	61772	IDT71256L100DB
	0C7V7	QP7C198L-100DMB
	3DTT2	P4C1256L-100CWMB
	<u>3</u> /	EDI8833LP100CB
5962-8855201YA	61772	IDT71256L100L32B
	0C7V7	QP7C198L-100LMB
	3DTT2	P4C1256L-100L32MB
	<u>3</u> /	EDI8833LP100LB
5962-8855201ZA	3DTT2	P4C1256L-100FSMB
	<u>3</u> /	IDT71256L100EB
5962-8855202MA	3DTT2	P4C1256L-70L28MB
	<u>3</u> /	IDT71256L70L28B
5962-8855202NA	0C7V7	QP7C199L-70KMB
	3DTT2	P4C1256L-70FMB
	<u>3</u> /	IDT71256L70XEB
5962-8855202UA	61772	IDT71256L70TDB
	0C7V7	QP7C199L-70DMB
	3DTT2	P4C1256L-70CMB
5962-8855202XA	61772	IDT71256L70DB
	0C7V7	QP7C198L-70DMB
	3DTT2	P4C1256L-70CWMB
	<u>3</u> /	MC51256L-70/B
	<u>3</u> /	EDI8833LP70CB

See footnotes at end of table.

The information contained herein is disseminated for convenience only and the Government assumes no liability whatsoever for any inaccuracies in the information bulletin.

STANDARD MICROCIRCUIT DRAWING BULLETIN - CONTINUED.

Standard microcircuit drawing PIN <u>1/</u>	Vendor CAGE number	Vendor similar PIN <u>2/</u>
5962-8855202YA	61772	IDT71256L70L32B
	0C7V7	QP7C198L-70LMB
	3DTT2	P4C1256L-70L32MB
	<u>3/</u>	MR51256L-70/B
	<u>3/</u>	EDI8833LP70LB
5962-8855202ZA	3DTT2	P4C1256L-70FSMB
	<u>3/</u>	IDT71256L70EB
5962-8855203MA	3DTT2	P4C1256L-55L28MB
	<u>3/</u>	L7C199KMB55L
	<u>3/</u>	IDT71256L55L28B
5962-8855203NA	0C7V7	QP7C199L-55KMB
	3DTT2	P4C1256L-55FMB
	<u>3/</u>	L7C199MMB55L
	<u>3/</u>	IDT71256L55XEB
5962-8855203UA	61772	IDT71256L55TDB
	0C7V7	QP7C199L-55DMB
	3DTT2	P4C1256L-55CMB
5962-8855203XA	61772	IDT71256L55DB
	0C7V7	QP7C198L-55DMB
	3DTT2	P4C1256L-55CWMB
	<u>3/</u>	L7C199HMB55L
5962-8855203YA	61772	IDT71256L55L32B
	0C7V7	QP7C198L-55LMB
	3DTT2	P4C1256L-55L32MB
	<u>3/</u>	L7C199TMB55L
5962-8855203ZA	3DTT2	P4C1256L-55FSMB
	<u>3/</u>	IDT71256L55EB
	<u>3/</u>	L7C199CMB55L
5962-8855204MA	3DTT2	P4C1256L-45L28MB
	<u>3/</u>	L7C199KMB45L
	<u>3/</u>	IDT71256L45L28B
5962-8855204NA	0C7V7	QP7C199L-45KMB
	3DTT2	P4C1256L-45FMB
	<u>3/</u>	L7C199CMB45L
	<u>3/</u>	IDT71256L45XEB
5962-8855204UA	61772	IDT71256L45TDB
	0C7V7	QP7C199L-45DMB
	3DTT2	P4C1256L-45CMB
	<u>3/</u>	L7C199CMB45L

See footnotes at end of table.

STANDARD MICROCIRCUIT DRAWING BULLETIN - CONTINUED.

Standard microcircuit drawing PIN <u>1/</u>	Vendor CAGE number	Vendor similar PIN <u>2/</u>
5962-8855204XA	61772	IDT71256L45DB
	0C7V7	QP7C198L-45DMB
	3DTT2	P4C1256L-45CWMB
	<u>3/</u>	MC51256L-45/B
	<u>3/</u>	L7C199IMB45L
5962-8855204YA	61772	IDT71256L45L32B
	0C7V7	QP7C198L-45LMB
	3DTT2	P4C1256L-45L32MB
	<u>3/</u>	MR51256L-45/B
	<u>3/</u>	L7C199TMB45L
5962-8855204ZA	3DTT2	P4C1256L-45FSMB
	<u>3/</u>	IDT71256L45EB
5962-8855205MA	0EU86	AS5C2568EC-35L/883C
	0C7V7	QP7C199L-35LMB
	3DTT2	P4C1256L-35L28MB
	<u>3/</u>	L7C199CMB35L
5962-8855205NA	0C7V7	QP7C199L-35KMB
	3DTT2	P4C1256L-35FMB
	<u>3/</u>	L7C199CMMB45L
5962-8855205TA	0EU86	AS5C2568F-35L/883C
	0C7V7	QP7C199L-35FMB
	3DTT2	P4C1256L-35FSSMB
	<u>3/</u>	EDI8833LP35FB
5962-8855205UA	0EU86	AS5C2568C-35L/883C
	0C7V7	QP7C199L-35DMB
	3DTT2	P4C1256L-35CMB
	<u>3/</u>	IDT71256L35TCB
	<u>3/</u>	L7C199CMB35L
	<u>3/</u>	EDI8833LPA35QB
5962-8855205XA	0EU86	AS5C2568CW-35L/883C
	0C7V7	QP7C198L-35DMB
	3DTT2	P4C1256L-35CWMB
	<u>3/</u>	IDT71256L35DB
	<u>3/</u>	L7C199IMB35L
	<u>3/</u>	EDI8833LP35CB
5962-8855205YA	0EU86	AS5C2568ECW-35L/883C
	0C7V7	QP7C198L-35LMB
	3DTT2	P4C1256L-35L32MB
	<u>3/</u>	IDT71256L35L32B
	<u>3/</u>	L7C199TMB35L
5962-8855205ZA	3DTT2	P4C1256L-35FSMB
	<u>3/</u>	IDT71256L35EB

See footnotes at end of table.

STANDARD MICROCIRCUIT DRAWING BULLETIN - CONTINUED.

Standard microcircuit drawing PIN <u>1/</u>	Vendor CAGE number	Vendor similar PIN <u>2/</u>
5962-8855206TA	0EU86	AS5C2568F-25L/883C
	0C7V7	QP7C199L-25FMB
	3DTT2	P4C1256L-25FSSMB
5962-8855206MA	0EU86	AS5C2568EC-25L/883C
	0C7V7	QP7C199L-25LMB
	3DTT2	P4C1256L-25L28MB
	<u>3/</u>	L7C199KMB25L
	<u>3/</u>	IDT71256L25L28B
5962-8855206NA	0C7V7	QP7C199L-25KMB
	3DTT2	P4C1256L-25FMB
	<u>3/</u>	L7C199MMB25L
	<u>3/</u>	IDT71256L25XEB
5962-8855206UA	61772	IDT71256L25TDB
	0EU86	AS5C2568C-25L/883C
	0C7V7	QP7C199L-25DMB
	3DTT2	P4C1256L-25CMB
	<u>3/</u>	L7C199CMB25L
5962-8855206XA	61772	IDT71256L25DB
	0EU86	AS5C2568CW-25L/883C
	0C7V7	QP7C198L-25DMB
	3DTT2	P4C1256L-25CWMB
	<u>3/</u>	L7C199IMB25L
5962-8855206YA	61772	IDT71256L25L32B
	0EU86	AS5C2568ECW-25L/883C
	0C7V7	QP7C198L-25LMB
	3DTT2	P4C1256L-25L32MB
	<u>3/</u>	L7C199TMB25L
5962-8855206ZA	3DTT2	P4C1256L-25FSMB
	<u>3/</u>	IDT71256L25EB
5962-8855207MA	0EU86	AS5C2568EC-70L/883C
	0C7V7	QP7C199L-70LMB
	3DTT2	P4C1256L-70L28MB
5962-8855207NA	0C7V7	QP7C199L-70KMB
	3DTT2	P4C1256L-70FMB
5962-8855207TA	0EU86	AS5C2568F-70L/883C
	0C7V7	QP7C199L-70FMB
	3DTT2	P4C1256L-70FSSMB
	<u>3/</u>	EDI8833LP70FB
5962-8855207UA	0EU86	AS5C2568C-70L/883C
	0C7V7	QP7C199L-70DMB
	3DTT2	P4C1256L-70CMB
	<u>3/</u>	IDT71256L70TCB
	<u>3/</u>	EDI8833LPA70QB

See footnotes at end of table.

STANDARD MICROCIRCUIT DRAWING BULLETIN - CONTINUED.

Standard microcircuit drawing PIN <u>1/</u>	Vendor CAGE number	Vendor similar PIN <u>2/</u>
5962-8855207XA	0EU86	AS5C2568CW-70L/883C
	0C7V7	QP7C198L-70DMB
	3DTT2	P4C1256L-70CWMB
	<u>3/</u>	IDT71256L70DB
	<u>3/</u>	EDI8833LP70CB
5962-8855207YA	0EU86	AS5C2568ECW-70L/883C
	0C7V7	QP7C198L-70LMB
	3DTT2	P4C1256L-70L32MB
	<u>3/</u>	IDT71256L70L32B
	<u>3/</u>	EDI8833LP70LB
5962-8855207ZA	<u>3/</u>	IDT71256L70EB
	3DTT2	P4C1256L-70FSMB
5962-8855208MA	0EU86	AS5C2568EC-55L/883C
	0C7V7	QP7C199L-55LMB
	3DTT2	P4C1256L-55L28MB
	<u>3/</u>	L7C199KMB55L
5962-8855208NA	0C7V7	QP7C199L-55KMB
	3DTT2	P4C1256L-55FMB
	<u>3/</u>	L7C199MMB55L
5962-8855208TA	0EU86	AS5C2568F-55L/883C
	0C7V7	QP7C199L-55FMB
	3DTT2	P4C1256L-55FSSMB
	<u>3/</u>	EDI8833LP55FB
5962-8855208UA	0EU86	AS5C2568C-55L/883C
	0C7V7	QP7C199L-55DMB
	3DTT2	P4C1256L-55CMB
	<u>3/</u>	IDT71256L55TCB
	<u>3/</u>	L7C199CMB55L
	<u>3/</u>	EDI8833LPA55QB
5962-8855208XA	0EU86	AS5C2568CW-55L/883C
	0C7V7	QP7C198L-55DMB
	3DTT2	P4C1256L-55CWMB
	<u>3/</u>	IDT71256L55DB
	<u>3/</u>	L7C199IMB55L
	<u>3/</u>	EDI8833LP55CB
5962-8855208YA	0EU86	AS5C2568ECW-55L/883C
	0C7V7	QP7C198L-55LMB
	3DTT2	P4C1256L-55L32MB
	<u>3/</u>	IDT71256L55L32B
	<u>3/</u>	L7C199TMB55L
	<u>3/</u>	EDI8833LP55LB
5962-8855208ZA	3DTT2	P4C1256L-55FSMB
	<u>3/</u>	IDT71256L55EB

See footnotes at end of table.

STANDARD MICROCIRCUIT DRAWING BULLETIN - CONTINUED.

Standard microcircuit drawing PIN <u>1/</u>	Vendor CAGE number	Vendor similar PIN <u>2/</u>
5962-8855209MA	<u>3/</u>	L7C199KMB45L
	0EU86	AS5C2568EC-45L/883C
	0C7V7	QP7C199L-45LMB
	3DTT2	P4C1256L-45L28MB
5962-8855209NA	<u>3/</u>	L7C199MMB45L
	0C7V7	QP7C199L-45KMB
	3DTT2	P4C1256L-45FMB
5962-8855209TA	<u>3/</u>	EDI8833LP45FB
	0EU86	AS5C2568F-45L/883C
	0C7V7	QP7C199L-45FMB
	3DTT2	P4C1256L-45FSSMB
5962-8855209UA	<u>3/</u>	IDT71256L45TCB
	<u>3/</u>	L7C199CMB45L
	<u>3/</u>	EDI8833LPA45QB
	0EU86	AS5C2568C-45L/883C
	0C7V7	QP7C199L-45DMB
	3DTT2	P4C1256L-45CMB
5962-8855209XA	<u>3/</u>	IDT71256L45DB
	<u>3/</u>	L7C199IMB45L
	<u>3/</u>	EDI8833LP45CB
	0EU86	AS5C2568CW-45L/883C
	0C7V7	QP7C198L-45DMB
	3DTT2	P4C1256L-45CWMB
5962-8855209YA	<u>3/</u>	IDT71256L45L32B
	<u>3/</u>	L7C199TMB45L
	<u>3/</u>	EDI8833LP45LB
	0EU86	AS5C2568ECW-45L/883C
	0C7V7	QP7C198L-45LMB
	3DTT2	P4C1256L-45L32MB
5962-8855209ZA	<u>3/</u>	IDT71256L45EB
	3DTT2	P4C1256L-45FSMB
5962-8855210MA	<u>3/</u>	L7C199KMB20L
	0EU86	AS5C2568EC-20L/883C
	0C7V7	QP7C199L-20LMB
	3DTT2	P4C1256L-20L28MB
5962-8855210NA	<u>3/</u>	L7C199MMB20L
	0C7V7	QP7C199L-20KMB
	3DTT2	P4C1256L-20FMB

See footnotes at end of table.

STANDARD MICROCIRCUIT DRAWING BULLETIN - CONTINUED.

Standard microcircuit drawing PIN <u>1</u> /	Vendor CAGE number	Vendor similar PIN <u>2</u> /
5962-8855210UA	<u>3</u> /	PDM41256LA20DB
	0EU86	AS5C2568C-20L/883C
	0C7V7	QP7C199L-20DMB
	3DTT2	P4C1256L-20CMB
5962-8855210XA	<u>3</u> /	L7C199IMB20L
	0EU86	AS5C2568CW-20L/883C
	0C7V7	QP7C198L-20DMB
	3DTT2	P4C1256L-20CWMB
5962-8855210YA	<u>3</u> /	PDM41256LA20L32B
	0EU86	AS5C2568ECW-20L/883C
	0C7V7	QP7C198L-20LMB
5962-8855210TA	3DTT2	P4C1256L-20L32MB
	0EU86	AS5C2568F-20L/883C
	0C7V7	QP7C199L-20FMB
5962-8855211MA	3DTT2	P4C1256L-20FSSMB
	<u>3</u> /	L7C199KMB17L
	0EU86	AS5C2568EC-17L/883C
5962-8855211NA	0C7V7	QP7C199L-17LMB
	3DTT2	P4C1256L-17L28MB
	<u>3</u> /	L7C199MMB17L
5962-8855211UA	0C7V7	QP7C199L-17KMB
	3DTT2	P4C1256L-17FMB
	<u>3</u> /	PDM41256LA17DB
5962-8855211XA	0EU86	AS5C2568C-17L/883C
	0C7V7	QP7C199L-17DMB
	3DTT2	P4C1256L-17CMB
5962-8855211YA	<u>3</u> /	L7C199IMB17L
	0EU86	AS5C2568CW-17L/883C
	0C7V7	QP7C198L-17DMB
	3DTT2	P4C1256L-17CWMB
5962-8855211TA	<u>3</u> /	PDM41256LA17L32B
	0EU86	AS5C2568ECW-17L/883C
	0C7V7	QP7C198L-17LMB
5962-8855211TA	3DTT2	P4C1256L-17L32MB
	0EU86	AS5C2568F-17L/883C
	0C7V7	QP7C199L-17FMB
	3DTT2	P4C1256L-17FSSMB

See footnotes at end of table.

STANDARD MICROCIRCUIT DRAWING BULLETIN - CONTINUED.

Standard microcircuit drawing PIN <u>1</u> /	Vendor CAGE number	Vendor similar PIN <u>2</u> /
5962-8855212MA	<u>3</u> /	L7C199KMB15L
	0EU86	AS5C2568EC-15L/883C
	0C7V7	QP7C199L-15LMB
	3DTT2	P4C1256L-15L28MB
5962-8855212NA	<u>3</u> /	L7C199MMB15L
	0C7V7	QP7C199L-15KMB
	3DTT2	P4C1256L-15FMB
5962-8855212UA	<u>3</u> /	PDM41256LA15DB
	0EU86	AS5C2568C-15L/883C
	0C7V7	QP7C199L-15DMB
	3DTT2	P4C1256L-15CMB
5962-8855212XA	<u>3</u> /	L7C199IMB15L
	0EU86	AS5C2568CW-15L/883C
	0C7V7	QP7C198L-15DMB
	3DTT2	P4C1256L-15CWMB
5962-8855212YA	<u>3</u> /	PDM41256LA15L32B
	0EU86	AS5C2568ECW-15L/883C
	0C7V7	QP7C198L-15LMB
	3DTT2	P4C1256L-15L32MB
5962-8855212TA	0EU86	AS5C2568F-15L/883C
	0C7V7	QP7C199L-15FMB
	3DTT2	P4C1256L-15FSSMB
5962-8855213XA	0EU86	AS5C2568CW-12L/883C
	0C7V7	QP7C198L-12DMB
5962-8855213YA	0EU86	AS5C2568ECW-12L/883C
	0C7V7	QP7C198L-12LMB
5962-8855213UA	0EU86	AS5C2568C-12L/883C
	0C7V7	QP7C199L-12DMB
5962-8855213TA	0EU86	AS5C2568F-12L/883C
	0C7V7	QP7C199L-12FMB
5962-8855213MA	0EU86	AS5C2568EC-12L/883C
	0C7V7	QP7C199L-12LMB
5962-8855213NA	0C7V7	QP7C199L-12KMB

See footnotes at end of table.

STANDARD MICROCIRCUIT DRAWING BULLETIN - CONTINUED.

DATE: 07-11-01

- 1/ The lead finish shown for each PIN representing a hermetic package is the most readily available from the manufacturer listed for that part. If the desired lead finish is not listed contact the Vendor to determine its availability.
- 2/ Caution. Do not use this number for item acquisition. Items acquired to this number may not satisfy the performance requirements of this drawing.
- 3/ No longer available from an approved source of supply.

<u>Vendor CAGE number</u>	<u>Vendor name and address</u>
61772	Integrated Device Technology, Inc. 6024 Silver Creek Valley Road San Jose, CA 95138
0EU86	Austin Semiconductor, Inc. 8701 Cross Park Drive Austin, TX 78754
0C7V7	QP Semiconductor 2945 Oakmead Village Court Santa Clara, CA 95051
3DTT2	Pyramid Semiconductor Corporation 1340 Bordeaux Drive Sunnyvale, CA 94089

X-ON Electronics

Largest Supplier of Electrical and Electronic Components

Click to view similar products for [SRAM](#) category:

Click to view products by [E2v](#) manufacturer:

Other Similar products are found below :

[5962-8855206XA](#) [CY6116A-35DMB](#) [CY7C128A-45DMB](#) [CY7C1461KV33-133AXI](#) [CY7C199-45LMB](#) [GS8161Z36DD-200I](#) [GS88237CB-200I](#) [R1QDA7236ABB-20IB0](#) [RMLV0408EGSB-4S2#AA0](#) [IS64WV3216BLL-15CTLA3](#) [IS66WVE4M16ECLL-70BLI](#) [PCF8570P](#) [K6T4008C1B-GB70](#) [CY7C1353S-100AXC](#) [AS6C8016-55BIN](#) [AS7C164A-15PCN](#) [515712X](#) [IS62WV51216EBLL-45BLI](#) [IS63WV1288DBLL-10HLI](#) [IS66WVE2M16ECLL-70BLI](#) [47L16-E/SN](#) [IS66WVE4M16EALL-70BLI](#) [IS62WV6416DBLL-45BLI](#) [IS61WV102416DBLL-10TLI](#) [CY7C1381KV33-100AXC](#) [CY7C1381KV33-100BZXI](#) [CY7C1373KV33-100AXC](#) [CY7C1381KVE33-133AXI](#) [CY7C4042KV13-933FCXC](#) [8602501XA](#) [5962-3829425MUA](#) [5962-8855206YA](#) [5962-8866201XA](#) [5962-8866201YA](#) [5962-8866204TA](#) [5962-8866206MA](#) [5962-8866207NA](#) [5962-8866208UA](#) [5962-8872502XA](#) [5962-8959836MZA](#) [5962-8959841MZA](#) [5962-9062007MXA](#) [5962-9161705MXA](#) [N08L63W2AB7I](#) [7130LA100PDG](#) [GS81284Z36B-250I](#) [M38510/28902BVA](#) [5962-8971203XA](#) [5962-8971202ZA](#) [5962-8872501LA](#)