

DEPARTMENT OF DEFENSE SPECIFICATION

MIL-PRF-38535 - Integrated Circuits, Manufacturing, General Specification for.

DEPARTMENT OF DEFENSE STANDARDS

MIL-STD-883 - Test Method Standard Microcircuits.
MIL-STD-1835 - Interface Standard Electronic Component Case Outlines.

DEPARTMENT OF DEFENSE HANDBOOKS

MIL-HDBK-103 - List of Standard Microcircuit Drawings.
MIL-HDBK-780 - Standard Microcircuit Drawings.

(Copies of these documents are available online at <https://assist.daps.dla.mil/quicksearch/> from the Standardization Document Order Desk, 700 Robbins Avenue, Building 4D, Philadelphia, PA 19111-5094.)

2.2 Order of precedence. In the event of a conflict between the text of this drawing and the references cited herein, the text of this drawing shall take precedence. Nothing in this document, however, supersedes applicable laws and regulations unless a specific exemption has been obtained.

3. REQUIREMENTS

3.1 Item requirements The individual item requirements shall be in accordance with MIL-PRF-38535, appendix A for non-JAN class level B devices and as specified herein. Product built to this drawing that is produced by a Qualified Manufacturer Listing (QML) certified and qualified manufacturer or a manufacturer who has been granted transitional certification to MIL-PRF-38535 may be processed as QML product in accordance with the manufacturer's approved program plan and qualifying activity approval in accordance with MIL-PRF-38535. This QML flow as documented in the Quality Management (QM) plan may make modifications to the requirements herein. These modifications shall not affect the PIN as described herein. A "Q" or "QML" certification mark in accordance with MIL-PRF-38535 is required to identify when the QML flow option is used.

3.2 Design, construction, and physical dimensions. The design, construction, and physical dimensions shall be as specified in MIL-PRF-38535, appendix A and herein.

3.2.1 Terminal connections. The terminal connections shall be as specified on figure 1.

3.2.2 Unprogrammed devices. Testing to the applicable truth table, or alternate testing as specified in 4.3.1d, shall be used for unprogrammed devices for contracts involving no altered item drawing. When testing is required per 4.3 herein, the devices shall be programmed by the manufacturer prior to test in a checkerboard pattern (a minimum of 50 percent of the total number of bits programmed) or to any altered item drawing pattern which includes at least 25 percent of the total number of bits programmed.

3.2.3 Programmed devices. The truth table for programmed devices shall be specified by an altered item drawing.

3.2.4 Case outlines. The case outlines shall be in accordance with 1.2.2 herein.

3.3 Electrical performance characteristics. Unless otherwise specified herein, the electrical performance characteristics are as specified in table I and shall apply over the full case operating temperature range.

3.4 Electrical test requirements. The electrical test requirements shall be the subgroups specified in table II. The electrical tests for each subgroup are described in table I.

3.5 Marking. Marking shall be in accordance with MIL-PRF-38535, appendix A. The part shall be marked with the PIN listed in 1.2 herein. In addition, the manufacturer's PIN may also be marked.

STANDARD MICROCIRCUIT DRAWING DLA LAND AND MARITIME COLUMBUS, OHIO 43218-3990	SIZE A		79024
		REVISION LEVEL D	SHEET 3

TABLE I. Electrical performance characteristics.

Test	Symbol	Conditions -55°C ≤ T _C ≤ +125°C 4.5 V ≤ V _{CC} ≤ 5.5 V unless otherwise specified	Group A subgroups	Device type	Limits		Unit
					Min	Max	
High level output voltage	V _{OH}	V _{IL} = 0.8 V, V _{IH} = 2.0 V I _{OH} = -2.0 mA, V _{CC} = 4.5 V	1, 2, 3	All	2.4		V
Low level output voltage	V _{OL}	V _{IL} = 0.8 V, V _{IH} = 2.0 V I _{OL} = 16 mA, V _{CC} = 4.5 V	1, 2, 3	All		0.5	V
Low level input voltage	V _{IL}	V _{CC} = 5.5 V	1, 2, 3	All		0.8	V
Input clamp voltage	V _{IC}	V _{CC} = 4.5 V, I _{IN} = -18 mA, Ambient temperature = 25°C	1, 2, 3	All		0.8	V
Input threshold voltage	V _{IH}	V _{CC} = 4.5 V	1, 2, 3	All	2.0		V
Address/enable input	I _{IH}	V _{IH} = 5.5 V	1, 2, 3	All		40	μA
Address/enable input	I _{IL}	V _{IN} = 0.45 V	1, 2, 3	All	-1.0	-250	μA
Output short-circuit current <u>1/</u> <u>2/</u>	I _{OS}	V _{OUT} = 0.2 V <u>1/</u>	1, 2, 3	All	-12	-100	mA
Output disable current	I _{OHE}	V _{CC} = 5.5 V, V _{OUT} = 2.4 V	1, 2, 3	All		40	μA
Output disable current	I _{OLE}	V _{OL} = 0.45 V, V _{OUT} = 5.5 V <u>2/</u>	1, 2, 3	All		-40	μA
Supply current	I _{CC}	V _{CC} = 5.5 V Disabled	1, 2, 3	All		80	mA
		All inputs grounded Enabled				185	
Input capacitance	C _{IN}	V _{IN} = 2.0 V dc; f = 1 MHz Ambient temperature = 25°C	4	All		8	pF
Address access time	t _{AVQV}	See figure 2 and 3	9, 10, 11	<u>01</u> <u>02</u>		<u>90</u> <u>75</u>	ns
Chip power-down delay to tri-state	t _{GVQZ}	See figure 2 and 3	9, 10, 11	All		50	ns
Chip power-up access time	t _{GVQV}	See figure 2 and 3	9, 10, 11	<u>01</u> <u>02</u>		<u>115</u> <u>225</u>	ns

1/ Not more than one output shall be shorted at a time for a maximum duration of one second.
2/ Device is in the three state.

**STANDARD
MICROCIRCUIT DRAWING**

**DLA LAND AND MARITIME
COLUMBUS, OHIO 43218-3990**

SIZE
A

79024

REVISION LEVEL
D

SHEET
4

3.5.1 Certification/compliance mark. The compliance mark for device class M shall be a "C" as required in MIL-PRF-38535, Appendix A.

3.6 Certificate of compliance. A certificate of compliance shall be required from a manufacturer in order to be listed as an approved source of supply in MIL-HDBK-103 (see 6.6 herein). The certificate of compliance submitted to DLA Land and Maritime-VA prior to listing as an approved source of supply shall affirm that the manufacturer's product meets the requirements of MIL-PRF-38535, appendix A and the requirements herein.

3.7 Certificate of conformance. A certificate of conformance as required in MIL-PRF-38535, appendix A shall be provided with each lot of microcircuits delivered to this drawing.

3.8 Notification of change. Notification of change to DLA Land and Maritime-VA shall be required for any change that affects this drawing..

3.9 Verification and review. DLA Land and Maritime, DLA Land and Maritime's agent and the acquiring activity retain the option to review the manufacturer's facility and applicable required documentation. Offshore documentation shall be made available onshore at the option of the reviewer.

4. VERIFICATION

4.1 Sampling and inspection. Sampling and inspection procedures shall be in accordance with MIL-PRF-38535, appendix A.

4.2 Screening. Screening shall be in accordance with method 5004 of MIL-STD-883, and shall be conducted on all devices prior to quality conformance inspection. The following additional criteria shall apply:

- a. Burn-in test (method 1015 of MIL-STD-883).
 - (1) Test condition C, D or E. The test circuit shall be maintained by the manufacturer under document revision level control and shall be made available to the preparing or procuring activity upon request. The test circuit shall specify the inputs, outputs, biases, and power dissipation, as applicable, in accordance with the intent specified in method 1015 of MIL-STD-883.
 - (2) $T_A = +125^{\circ}\text{C}$, minimum.
- b. Interim and final electrical test parameters shall be as specified in table II herein, except interim electrical parameter tests prior to burn-in are optional at the discretion of the manufacturer.

4.3 Quality conformance inspection. Quality conformance inspection shall be in accordance with method 5005 of MIL-STD-883 including groups A, B, C, and D inspections. The following additional criteria shall apply.

4.3.1 Group A inspection.

- a. Tests shall be as specified in table II herein.
- b. Subgroups 5 and 6 in table I, method 5005 of MIL-STD-883 shall be omitted.
- c. Subgroup 4 (C_{IN} measurement) shall be measured only for the initial test and after process or design changes which may affect input capacitance.
- d. Unprogrammed devices shall be tested for programmability and ac performance compliance to the requirements of group A, subgroups 9, 10, and 11. Either of two techniques is acceptable:
 - (1) Testing the entire lot using additional built-in test circuitry which allows the manufacturer to verify programmability and ac performance without programming the user array. If this is done, the resulting test patterns shall be verified on all devices during subgroups 9, 10, and 11, group A testing per the sampling plan specified in MIL-STD-883, method 5005.
 - (2) If such compliance cannot be tested on an unprogrammed device, a sample shall be selected to satisfy programmability requirements prior to performing subgroups 9, 10, and 11. Twelve devices shall be submitted to programming. If more than 2 devices fail to program, the lot shall be rejected. At the manufacturer's option, the sample may be increased to 24 total devices with no more than 4 total device failures allowable. Ten devices from the programmability sample shall be submitted to the requirements of group A, subgroups 9, 10, and 11. If more than 2 total devices fail, the lot shall be rejected. At the manufacturer's option, the sample may be increased to 20 total devices with no more than 4 total device failures allowable.

STANDARD MICROCIRCUIT DRAWING DLA LAND AND MARITIME COLUMBUS, OHIO 43218-3990	SIZE A		79024
		REVISION LEVEL D	SHEET 5

Device Types	All		
Case Outlines	J, K, L	X	3
Terminal Number	Terminal Symbol	Terminal Symbol	Terminal Symbol
1	A7	NC	NC
2	A6	NC	A7
3	A5	A7	A6
4	A4	A6	A5
5	A3	A5	A4
6	A2	A4	A3
7	A1	A3	A2
8	A0	A2	A1
9	Q0	A1	A0
10	Q1	A0	NC
11	Q2	NC	Q0
12	VSS	Q0	Q1
13	Q3	Q1	Q2
14	Q4	Q2	VSS
15	Q5	NC	NC
16	Q6	VSS	Q3
17	Q7	Q3	Q4
18	E4	NC	Q5
19	E3	Q4	Q6
20	-	Q5	Q7
21	E1	Q6	NC
22	A9	Q7	E4
23	A8	NC	E3
24	VCC	E4	-
25	---	E3	E2
26	---	-	E1
27	---	E2	A9
28	---	NC	A8
29	---	-	-
30	---	E1	VCC
31	---	A9	---
32	---	A8	---
		NC	---
		VCC	---

Note: --- means no terminal

FIGURE 1. Terminal connections.

STANDARD MICROCIRCUIT DRAWING DLA LAND AND MARITIME COLUMBUS, OHIO 43218-3990	SIZE A		79024
		REVISION LEVEL D	SHEET 6

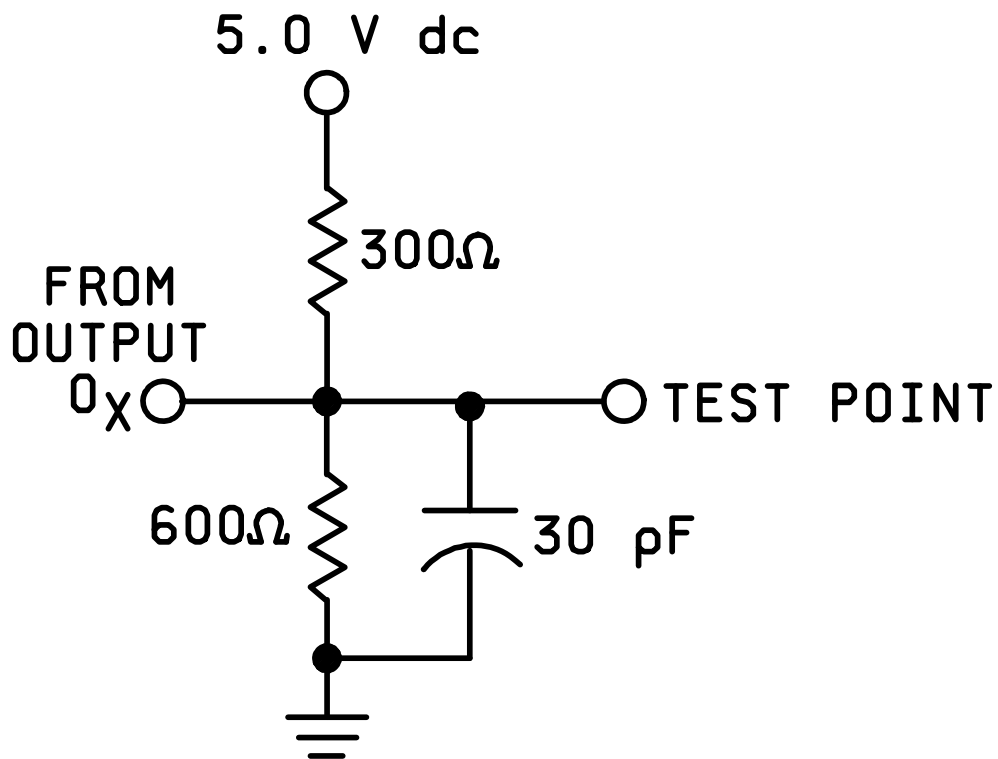

NOTES:

1. The tolerance for all load components is ± 5 percent.
2. The load capacitance includes the test jig and probe capacitances.
3. All device test loads should be located within two inches of device output pin.
4. Use this circuit or equivalent to test the outputs.

FIGURE 2. AC test load circuit.

STANDARD MICROCIRCUIT DRAWING DLA LAND AND MARITIME COLUMBUS, OHIO 43218-3990	SIZE A		79024
		REVISION LEVEL D	SHEET 7

Device type 02

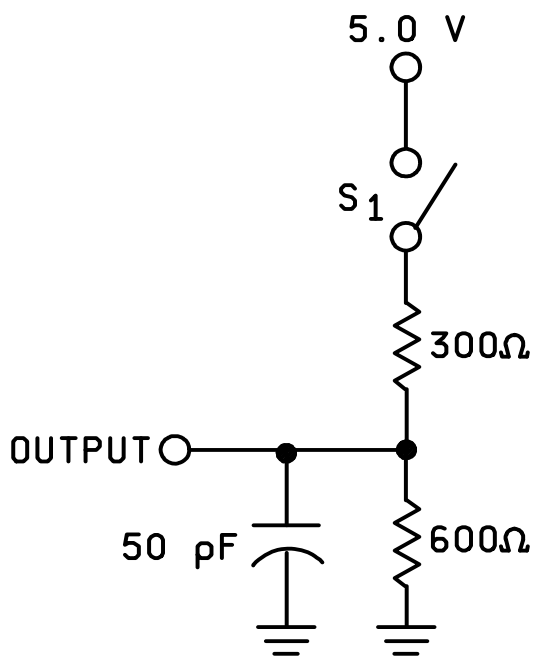

Output load for all switching tests except t_{GVQZ} .

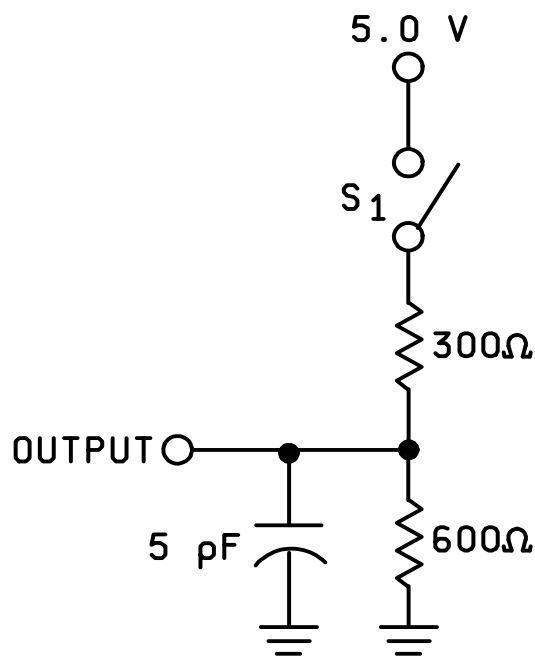

Output load for t_{GVQZ} .

NOTES:

1. All device test loads should be located within two inches of device output pin.
2. S_1 is open for output data high to high-Z and high-Z to output data high tests.
 S_1 is closed for all other switching tests.
3. The load capacitance includes all stray and fixture capacitance.

FIGURE 2. AC test load circuit - continued.

STANDARD MICROCIRCUIT DRAWING DLA LAND AND MARITIME COLUMBUS, OHIO 43218-3990	SIZE A		79024
		REVISION LEVEL D	SHEET 8

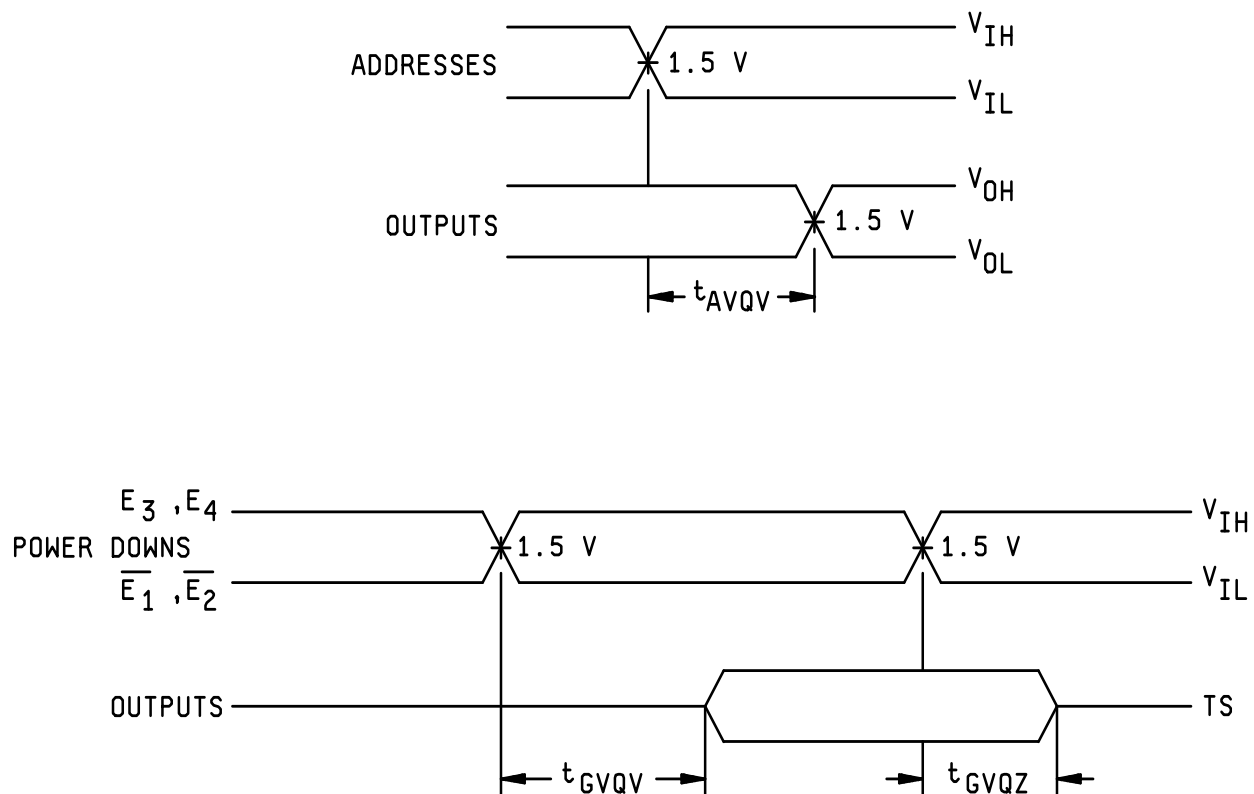

FIGURE 3. Switching time definitions.

**STANDARD
MICROCIRCUIT DRAWING**
DLA LAND AND MARITIME
COLUMBUS, OHIO 43218-3990

SIZE
A

79024

REVISION LEVEL
D

SHEET
9

TABLE II. Electrical test requirements. 1/ 2/

MIL-STD-883 test requirements	Subgroups (in accordance with MIL-STD-883, method 5005, table I)
Interim electrical parameters (method 5004)	- - -
Final electrical test parameters (method 5004)	1*, 2, 3, 9
Group A test requirements (method 5005)	1, 2, 3, 7, 8, 9, 10, 11
Groups C and D end-point electrical parameters (method 5005)	1, 2, 3

* PDA applies to subgroup 1.

4.3.2 Groups C and D inspections.

- a. End-point electrical parameters shall be as specified in table II herein.
- b. Steady-state life test conditions, method 1005 of MIL-STD-883.
 - (1) Test condition C, D or E. The test circuit shall be maintained by the manufacturer under document revision level control and shall be made available to the preparing or procuring activity upon request. The test circuit shall specify the inputs, outputs, biases, and power dissipation, as applicable, in accordance with the intent specified in method 1005 of MIL-STD-883.
 - (2) T_A = +125°C, minimum.
 - (3) Test duration: 1,000 hours, except as permitted by method 1005 of MIL-STD-883.

5. PACKAGING

5.1 Packaging requirements. The requirements for packaging shall be in accordance with MIL-PRF-38535, appendix A.

6. NOTES

6.1 Intended use. Microcircuits conforming to this drawing are intended for use for government microcircuit applications (original equipment), design applications, and logistics purposes.

6.2 Replaceability. Microcircuits covered by this drawing will replace the same generic device covered by a contractor-prepared specification or drawing.

6.3 Configuration control of SMD's. All proposed changes to existing SMD's will be coordinated with the users of record for the individual documents. This coordination will be accomplished using DD Form 1692, Engineering Change Proposal.

6.4 Record of users. Military and industrial users should inform DLA Land and Maritime when a system application requires configuration control and which SMD's are applicable to that system. DLA Land and Maritime will maintain a record of users and this list will be used for coordination and distribution of changes to the drawings. Users of drawings covering microelectronic devices (FSC 5962) should contact DLA Land and Maritime-VA, telephone (614) 692-0544

6.5 Comments. Comments on this drawing should be directed to DSCC-VA, Columbus, Ohio 43218-3990, or telephone 614-692-0540.

6.6 Approved source of supply. An approved source of supply is listed herein. Additional sources will be added as they become available. The vendor listed herein has agreed to this drawing and a certificate of compliance (see 3.6 herein) has been submitted to DLA Land and Maritime-VA.

STANDARD MICROCIRCUIT DRAWING DLA LAND AND MARITIME COLUMBUS, OHIO 43218-3990	SIZE A		79024
		REVISION LEVEL D	SHEET 10

STANDARD MICROCIRCUIT DRAWING BULLETIN

DATE: 11-01-20

Approved sources of supply for SMD 79024 are listed below for immediate acquisition information only and shall be added to MIL-HDBK-103 and QML-38535 during the next revision. MIL-HDBK-103 and QML-38535 will be revised to include the addition or deletion of sources. The vendors listed below have agreed to this drawing and a certificate of compliance has been submitted to and accepted by DLA Land and Maritime-VA. This information bulletin is superseded by the next dated revisions of MIL-HDBK-103 and QML-38535. DLA Land and Maritime maintains an online database of all current sources of supply at <http://www.dsccl.dla.mil/Programs/Smcr/>.

Standard microcircuit drawing PIN <u>1/</u>	Vendor CAGE number	Vendor similar PIN <u>2/</u>
7902401JA	0C7V7 <u>3/</u>	R29633 29633DMB
	<u>3/</u>	HM-7681P-8
7902402JA	0C7V7 <u>3/</u>	R29633 AM27PS181/BJA
7902402KA	0C7V7 <u>3/</u>	R29633 AM27PS181/BKA
79024023A	0C7V7 <u>3/</u>	R29633 AM27PS181/B3A
7902402XA	0C7V7 <u>3/</u>	R29633 AM27PS181/BUA
7902402LA	0C7V7 <u>3/</u>	R29633 AM27PS181/BLA

- 1/ The lead finish shown for each PIN representing a hermetic package is the most readily available from the manufacturer listed for that part. If the desired lead finish is not listed contact the Vendor to determine its availability.
- 2/ Caution. Do not use this number for item acquisition. Items acquired to this number may not satisfy the performance requirements of this drawing.
- 3/ No longer available from an approved source.

Vendor CAGE
number

0C7V7

Vendor name
and address

QP Semiconductor.
2945 Oakmead Village Court
Santa Clara, CA 95051

The information contained herein is disseminated for convenience only and the Government assumes no liability whatsoever for any inaccuracies in the information bulletin.

X-ON Electronics

Largest Supplier of Electrical and Electronic Components

Click to view similar products for [e2v manufacturer](#):

Other Similar products are found below :

[5962-89841063A](#) [M38510/06102BFA](#) [M38510/75001BCA\(NSC\)](#) [EV12DS460AMZPY](#) [5962-8764803XA](#) [M38510/10301BHA](#) [5962-8872607LA](#) [5962-9457701QLA\(NSC\)](#) [8413202RA](#) [5962-9172201MEA](#) [5962-8983901RA\(E2VLATTICE\)](#) [5962-88670023A\(CYPRESS\)](#) [5962-8751601CA](#) [5962-9174402MXA\(CYPRESS\)](#) [M38510/06202BFA](#) [M38510/10107BHA\(LTC\)](#) [5962-9080308MKA](#) [5962-9218701M2A\(E2VNSC\)](#) [5962-9062007MXA](#) [M38510/10304BCA](#) [5962-8867004LA\(E2VCYPRESS\)](#) [585R727H06](#) [5962-8873502LA\(ST\)](#) [M38510/11302BEA\(FSC-RAY\)](#) [8602501YA](#) [5962-8968801EA\(E2VNSC\)](#) [M38510/33401B2A\(NSC\)](#) [5962-88734033A\(ST\)](#) [5962-9682901Q2A\(NSC\)](#) [5962-8752902LA\(ST\)](#) [5962-9469601MFA\(E2VNSC\)](#) [5962-87760012A\(E2VNSC\)](#) [M38510/00302BCA](#) [M38510/00302BCA\(E2VNSC\)](#) [5962-89841043A\(CYPRESS\)](#) [5962-87515033C\(ST\)](#) [5962-9154507MXA](#) [M38510/10305BFA](#) [5962-9161708MYA](#) [5962-8871310RA](#) [5962-8765001KA\(ST\)](#) [5962-9172201MFA\(NSC\)](#) [M38510/10304BHA\(FSC-RAY\)](#) [QP27C256L-120/XIA](#) [QP82S100/BYA-MIL](#) [5962-8955201FA\(NSC\)](#) [M38510/10802BCA](#) [5962-8873503LA](#) [5962-8873503LA\(E2VST\)](#) [5962-8851806LA](#)