

REVISIONS

LTR	DESCRIPTION	DATE (YR-MO-DA)	APPROVED
F	Change to vendor similar part number for vendor CAGE 18324. Changes to table I parameters t_{EA} and C_{OUT} . Add vendor CAGE 18324 to device types 03 and 04 as a source of supply. Add new device design for device 04 for vendor CAGE 07933. Removed table III, figure 5, and programming procedures. Editorial changes throughout.	91-10-30	M. A. Frye
G	Changes in accordance with NOR 5962-R010-93	93-02-12	M. A. Frye
H	Changes in accordance with NOR 5962-R205-93	93-08-10	M. A. Frye
J	Updated boilerplate. Sheet 4, change V_{OH} conditions from $I_{OH} = -2.0$ mA to -1.6 mA; change C_{IN} max. limit from 10 pF to 15 pF; change C_{OUT} max. limit for devices 01, 02, and 04 from 13 pF to 20 pF; add footnote 3 to t_{DA} test column. Removed logic diagrams. Remove vendors CAGE 50364 and 34335 as suppliers, and removed their associated switching time test circuits.	97-05-29	Raymond Monnin
K	Boilerplate update, part of 5 year review. ksr	05-06-30	Raymond Monnin
L	Boilerplate update, part of 5 year review. ksr	10-11-10	Charles F. Saffle

CURRENT CAGE CODE 67268

THE ORIGINAL FIRST SHEET OF THIS DRAWING HAS BEEN REPLACED

REV																				
SHEET																				
REV																				
SHEET																				
REV STATUS OF SHEETS	REV SHEET	L	L	L	L	L	L	L	L	L	L	L	L	L	L	L	L	L	L	L
PMIC N/A	PREPARED BY Darrell Hill	<p align="center">DLA LAND AND MARITIME COLUMBUS, OHIO 43218-3990 http://www.dsccl.dla.mil</p> <p>MICROCIRCUIT, MEMORY, DIGITAL, SCHOTTKY BIPOLAR 32K PROGRAMMABLE READ ONLY MEMORY (PROM), MONOLITHIC SILICON</p>																		
<p align="center">STANDARD MICROCIRCUIT DRAWING</p> <p>THIS DRAWING IS AVAILABLE FOR USE BY ALL DEPARTMENTS AND AGENCIES OF THE DEPARTMENT OF DEFENSE</p> <p align="center">AMSC N/A</p>	CHECKED BY C. R. Jackson																			
	APPROVED BY N. A. Hauck																			
	DRAWING APPROVAL DATE 82-09-01																			
	REVISION LEVEL L	SIZE A	CAGE CODE 14933	82008																
		SHEET 1 OF 13																		

1. SCOPE

1.1 Scope. This drawing describes device requirements for MIL-STD-883 compliant, non-JAN class level B microcircuits in accordance with MIL-PRF-38535, appendix A.

1.2 Part or Identifying Number (PIN). The complete PIN is as shown in the following example:

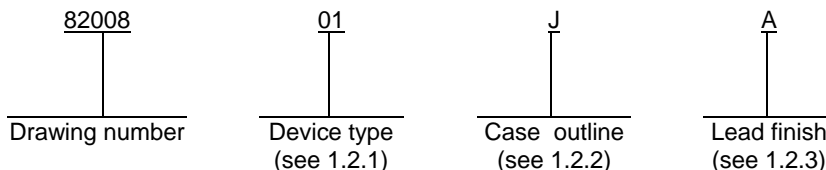

1.2.1 Device type(s). The device type(s) identify the circuit function as follows:

<u>Device type</u>	<u>Generic number</u> ^{1/}	<u>Circuit function</u>	<u>Access time</u>
01		4096 words x 8 bits per word PROM, T.S.	95 ns
02		4096 words x 8 bits per word PROM, T.S.	55 ns
03		4096 words x 8 bits per word PROM, T.S.	45 ns
04		4096 words x 8 bits per word PROM, T.S.	70 ns

1.2.2 Case outline(s). The case outline(s) are as designated in MIL-STD-1835 and as follows:

<u>Outline letter</u>	<u>Descriptive designator</u>	<u>Terminals</u>	<u>Package style</u>
J	GDIP1-T24 or CDIP2-T24	24	dual-in-line package
K	GDIP2-F24 or CDFP3-F24	24	flat package
L	GDIP3-T24 or CDIP4-T24	24	dual-in-line package
X	CQCC1-N32	32	rectangular leadless chip carrier
3	CQCC1-N28	28	square leadless chip carrier
Y	CDFP4-F24	24	flat package

1.2.3 Lead finish. The lead finish is as specified in MIL-PRF-38535, appendix A.

1.3 Absolute maximum ratings.

Supply voltage (V_{CC}).....	-0.3 to +7.0 V dc
Input voltage range.....	+5.5 V dc
Storage temperature range	-65°C to +150°C
Lead temperature (soldering, 10 seconds)	+300°C
Thermal resistance, junction-to-case (θ_{JC})	See MIL-STD-1835 ^{2/}
Output voltage applied.....	-0.3 V dc to V_{CC}
Output sink current	100 mA
Maximum power dissipation (P_D) ^{3/}	1.04 W dc
Maximum junction temperature (T_J).....	+175°C

1.4 Recommended operating conditions.

Supply voltage range (V_{CC}).....	4.5 V dc to 5.5 V dc
Minimum high level input voltage (V_{IH})	2.0 V dc
Maximum low level input voltage (V_{IL})	0.8 V dc
Normalized fanout (each output)	12 mA
Case operating temperature range (T_C)	-55°C to +125°C

- ^{1/} Generic numbers are listed on the Standardized Military Drawing Source Approval Bulletin at the end of this document and will also be listed in MIL-HDBK-103.
- ^{2/} Heat sinking is recommended to reduce the junction temperature.
- ^{3/} Must withstand the added P_D due to short circuit test (e.g., I_{OS}).

STANDARD MICROCIRCUIT DRAWING DLA LAND AND MARITIME COLUMBUS, OHIO 43218-3990	SIZE A		82008
		REVISION LEVEL L	SHEET 2

2. APPLICABLE DOCUMENTS

2.1 Government specification, standards, and handbooks. The following specification, standards, and handbooks form a part of this drawing to the extent specified herein. Unless otherwise specified, the issues of these documents are those cited in the solicitation or contract.

DEPARTMENT OF DEFENSE SPECIFICATION

MIL-PRF-38535 - Integrated Circuits, Manufacturing, General Specification for.

DEPARTMENT OF DEFENSE STANDARDS

MIL-STD-883 - Test Method Standard Microcircuits.
 MIL-STD-1835 - Interface Standard Electronic Component Case Outlines.

DEPARTMENT OF DEFENSE HANDBOOKS

MIL-HDBK-103 - List of Standard Microcircuit Drawings.
 MIL-HDBK-780 - Standard Microcircuit Drawings.

(Copies of these documents are available online at <https://assist.daps.dla.mil/quicksearch/> or from the Standardization Document Order Desk, 700 Robbins Avenue, Building 4D, Philadelphia, PA 19111-5094.)

2.2 Order of precedence. In the event of a conflict between the text of this drawing and the references cited herein, the text of this drawing takes precedence. Nothing in this document, however, supersedes applicable laws and regulations unless a specific exemption has been obtained.

3. REQUIREMENTS

3.1 Item requirements. The individual item requirements shall be in accordance with MIL-PRF-38535, appendix A for non-JAN class level B devices and as specified herein. Product built to this drawing that is produced by a Qualified Manufacturer Listing (QML) certified and qualified manufacturer or a manufacturer who has been granted transitional certification to MIL-PRF-38535 may be processed as QML product in accordance with the manufacturers approved program plan and qualifying activity approval in accordance with MIL-PRF-38535. This QML flow as documented in the Quality Management (QM) plan may make modifications to the requirements herein. These modifications shall not affect form, fit, or function of the device. These modifications shall not affect the PIN as described herein. A "Q" or "QML" certification mark in accordance with MIL-PRF-38535 is required to identify when the QML flow option is used.

3.2 Design, construction, and physical dimensions. The design, construction, and physical dimensions shall be as specified in MIL-PRF-38535, appendix A and herein.

3.2.1 Case outline(s). The case outline(s) shall be in accordance with 1.2.2 herein.

3.2.2 Terminal connections. The terminal connections shall be as specified on figure 1.

3.2.3 Truth table(s). The truth table(s) shall be as specified on figure 2.

3.2.3.1 Unprogrammed devices. The truth table for unprogrammed devices for contracts involving no altered item drawing shall be as specified on figure 2. When required in groups A or C (see 4.3), the devices shall be programmed by the manufacturer prior to test in a checkerboard pattern (a minimum of 50 percent of the total number of bits programmed).

3.2.3.2 Programmed devices. The requirements for supplying programmed devices are not part of this drawing.

STANDARD MICROCIRCUIT DRAWING DLA LAND AND MARITIME COLUMBUS, OHIO 43218-3990	SIZE A		82008
		REVISION LEVEL L	SHEET 3

TABLE I. Electrical performance characteristics.

Test	Symbol	Conditions -55°C ≤ T _C ≤ +125°C V _{CC} = 4.5 V to 5.5 V unless otherwise specified	Device type	Group A subgroups	Limits		Unit
					Min	Max	
High level output voltage	V _{OH}	V _{CC} = minimum, I _{OH} = -1.6 mA	All	1, 2, 3	2.4		V
Low level output voltage	V _{OL}	V _{CC} = minimum, I _{OL} = 16mA	All	1, 2, 3		0.5	V
Input clamp voltage	V _{IC}	I _{IN} = -18 mA	All	1, 2, 3		-1.5	V
High impedance (Off-state) output high current	I _{OZH}	V _{CC} = V _{CC} maximum V _O = 2.4 V	01	1, 2, 3		100	μA
			02,03,04			40	
High impedance (Off-state) output low current	I _{OLZ}	V _{CC} = V _{CC} maximum V _O = 0.4 V	01	1, 2, 3		-100	μA
			02,03,04			-40	
High level input current	I _{IH}	V _{IH} = V _{CC} maximum	All	1, 2, 3		40	μA
Low level input current	I _{IL}	V _{IL} = 0.4 V V _{CC} = V _{CC} maximum	All	1, 2, 3		-250	μA
Short circuit output current	I _{OS}	V _{OUT} = 0.2 V <u>1/</u>	All	1, 2, 3	-15	-100	mA
Supply current	I _{CC}	V _{CC} = V _{CC} maximum, all inputs grounded	All	1, 2, 3		190	mA
Input capacitance	C _{IN}	V _{CC} = 5 V, f = 1 MHz, V _{IN} = 2.0 V, see 4.3.1c	All	4		15	pF
Output capacitance	C _{OUT}	V _{CC} = 5 V, f = 1 MHz, V _{OUT} = 2.0 V, see 4.3.1c	01, 02, 04	4		20	pF
			03			12	
Address access time	t _{AA}	V _{CC} = 4.5 V and 5.5 V, see figure 4	01	9, 10, 11		95	ns
			02			55	
			03			45	
			04			70	
Chip enable access time	t _{EA}		01, 04			45	ns
			02, 03			35	
Chip disable access time <u>2/</u> <u>3/</u>	t _{DA}		01			45	ns
			02, 03, 04			35	

1/ Not more than one output shall be grounded at one time, for a maximum of 1 second.

2/ C_L ≥ 5 pF.

3/ May not be tested but is guaranteed to the limits specified in table I.

**STANDARD
MICROCIRCUIT DRAWING**
DLA LAND AND MARITIME
COLUMBUS, OHIO 43218-3990

SIZE
A

82008

REVISION LEVEL
L

SHEET
4

Device Types	All		
Case Outlines	J, K, Y, L	X	3
Terminal Number	Terminal Symbol		
1	A ₇	NC	NC
2	A ₆	NC	A ₇
3	A ₅	A ₇	A ₆
4	A ₄	A ₆	A ₅
5	A ₃	A ₅	A ₄
6	A ₂	A ₄	A ₃
7	A ₁	A ₃	A ₂
8	A ₀	A ₂	A ₁
9	O ₁	A ₁	A ₀
10	O ₂	A ₀	NC
11	O ₃	NC	O ₁
12	GND	O ₁	O ₂
13	O ₄	O ₂	O ₃
14	O ₅	O ₃	GND
15	O ₆	NC	NC
16	O ₇	GND	O ₄
17	O ₈	O ₄	O ₅
18	CE ₂	NC	O ₆
19	A ₁₁	O ₅	O ₇
20	\overline{CE}_1	O ₆	O ₈
21	A ₁₀	O ₇	NC
22	A ₉	O ₈	CE ₂
23	A ₈	NC	A ₁₁
24	V _{CC}	CE ₂	\overline{CE}_1
25	---	A ₁₁	A ₁₀
26	---	\overline{CE}_1	A ₉
27	---	NC	A ₈
28	---	A ₁₀	V _{CC}
29	---	A ₉	---
30	---	A ₈	---
31	---	NC	---
32	---	V _{CC}	---

FIGURE 1. Terminal connections.

STANDARD MICROCIRCUIT DRAWING DLA LAND AND MARITIME COLUMBUS, OHIO 43218-3990	SIZE A		82008
		REVISION LEVEL L	SHEET 5

Word number			Address												Data							
	\overline{CE}_1	CE_2	A ₁₁	A ₁₀	A ₉	A ₈	A ₇	A ₆	A ₅	A ₄	A ₃	A ₂	A ₁	A ₀	O ₈	O ₇	O ₆	O ₅	O ₄	O ₃	O ₂	O ₁
NA	L	H	X	X	X	X	X	X	X	X	X	X	X	X	See note 5							
	H	L	X	X	X	X	X	X	X	X	X	X	X	X	OC	OC	OC	OC	OC	OC	OC	OC

Notes:

1. NA = Not applicable.
2. X = Input may be high level, low level, or open circuit.
3. OC = Open circuit (high resistance output).
4. Program readout can only be accomplished with enable input at low level.
5. The outputs for an unprogrammed device shall be high for circuits C and F.

FIGURE 2. Truth table (unprogrammed).

STANDARD MICROCIRCUIT DRAWING DLA LAND AND MARITIME COLUMBUS, OHIO 43218-3990	SIZE A		82008
		REVISION LEVEL L	SHEET 6

Circuit F

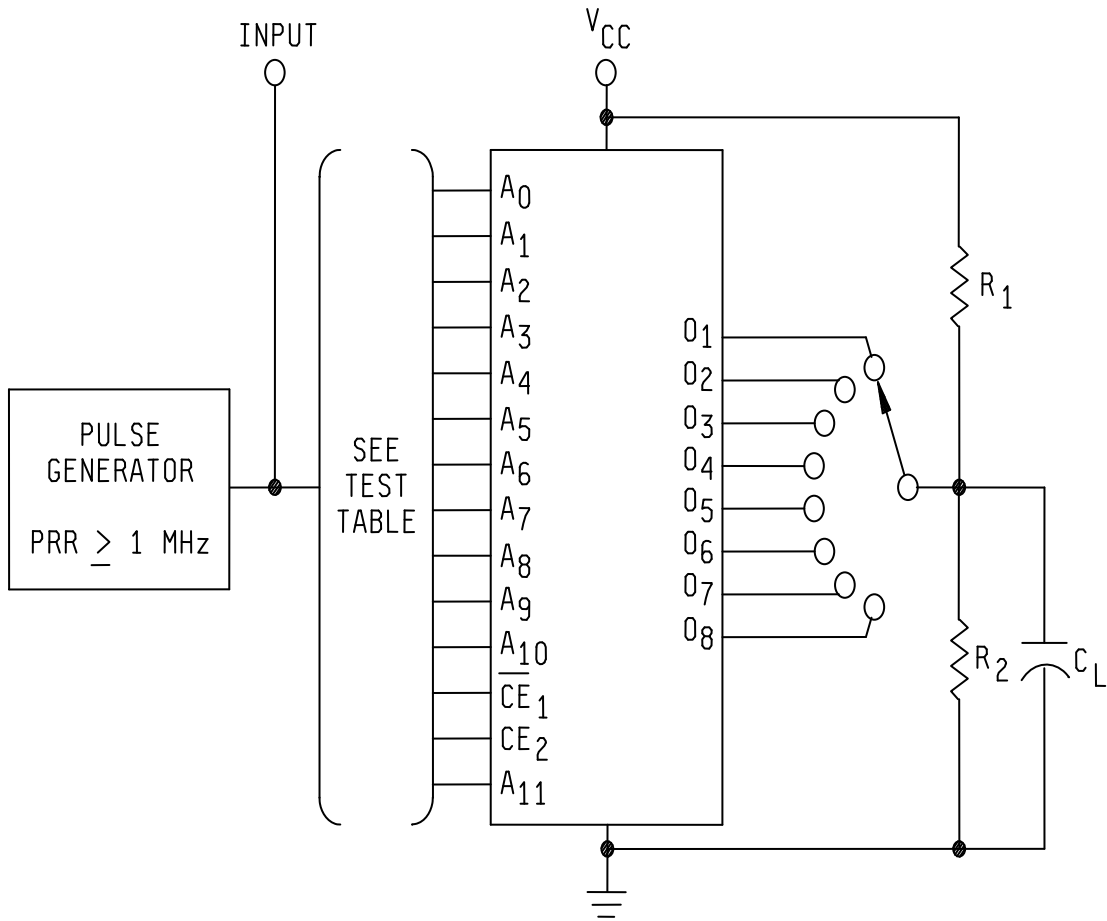

Notes:

1. Test table for devices programmed in accordance with an altered item drawing may be replaced by the equivalent tests which apply to the specific program configuration of the resulting read-only memory.
2. $C_L = 30 \text{ pF}$ minimum, including jig and probe capacitance: $R_1 = 300\Omega$ and $R_2 = 600\Omega$.
3. Outputs may be under load simultaneously.
4. V_{OLAC} and V_{OHAC} are the measured output voltage levels while enabled.

FIGURE 3. Switching time test circuits and waveforms.

STANDARD MICROCIRCUIT DRAWING DLA LAND AND MARITIME COLUMBUS, OHIO 43218-3990	SIZE A		82008
		REVISION LEVEL L	SHEET 7

Circuit F Continued

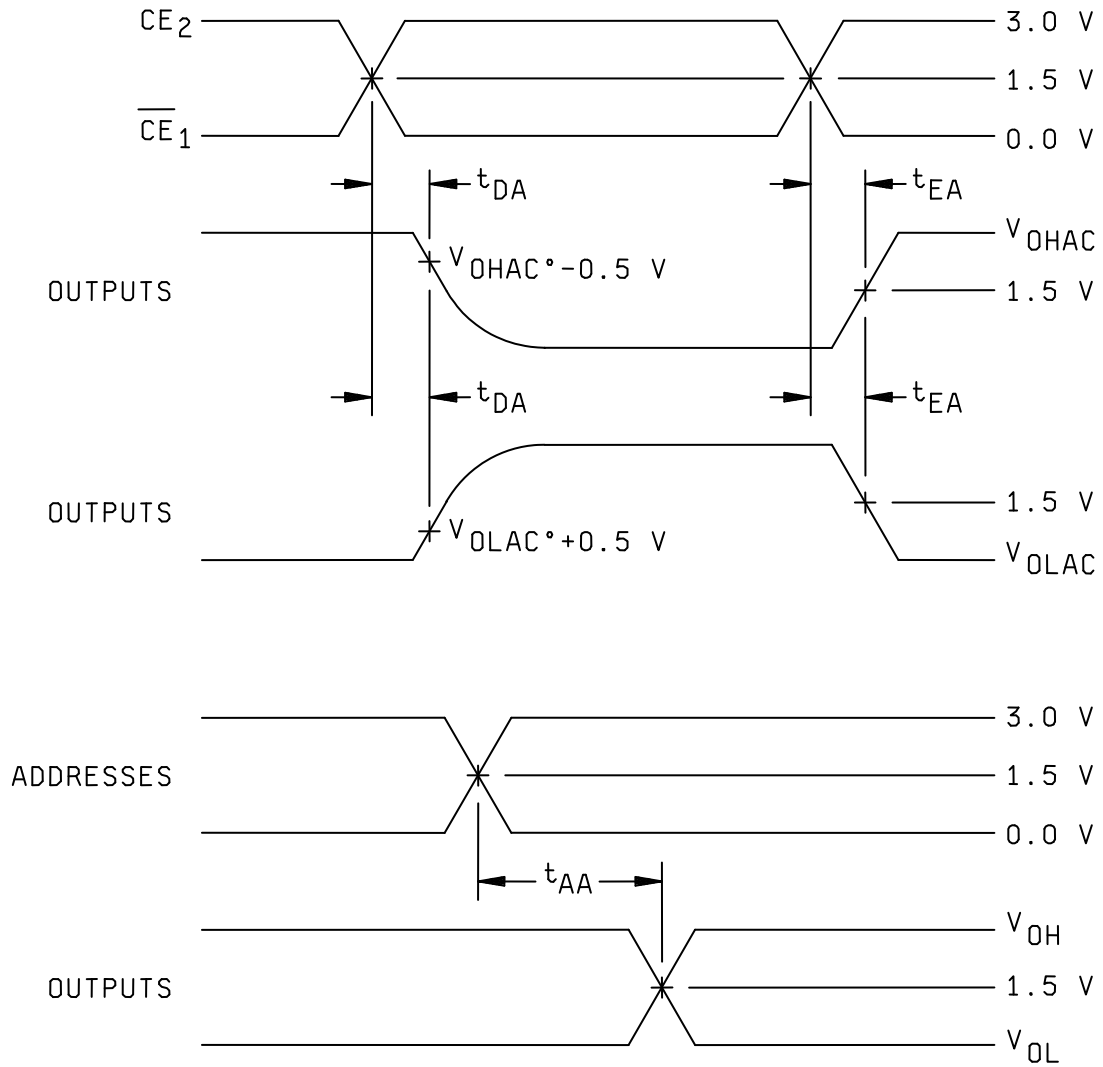

FIGURE 3. Switching time test circuits and waveforms – Continued.

**STANDARD
MICROCIRCUIT DRAWING**
DLA LAND AND MARITIME
COLUMBUS, OHIO 43218-3990

SIZE
A

82008

REVISION LEVEL
L

SHEET
8

Circuit C

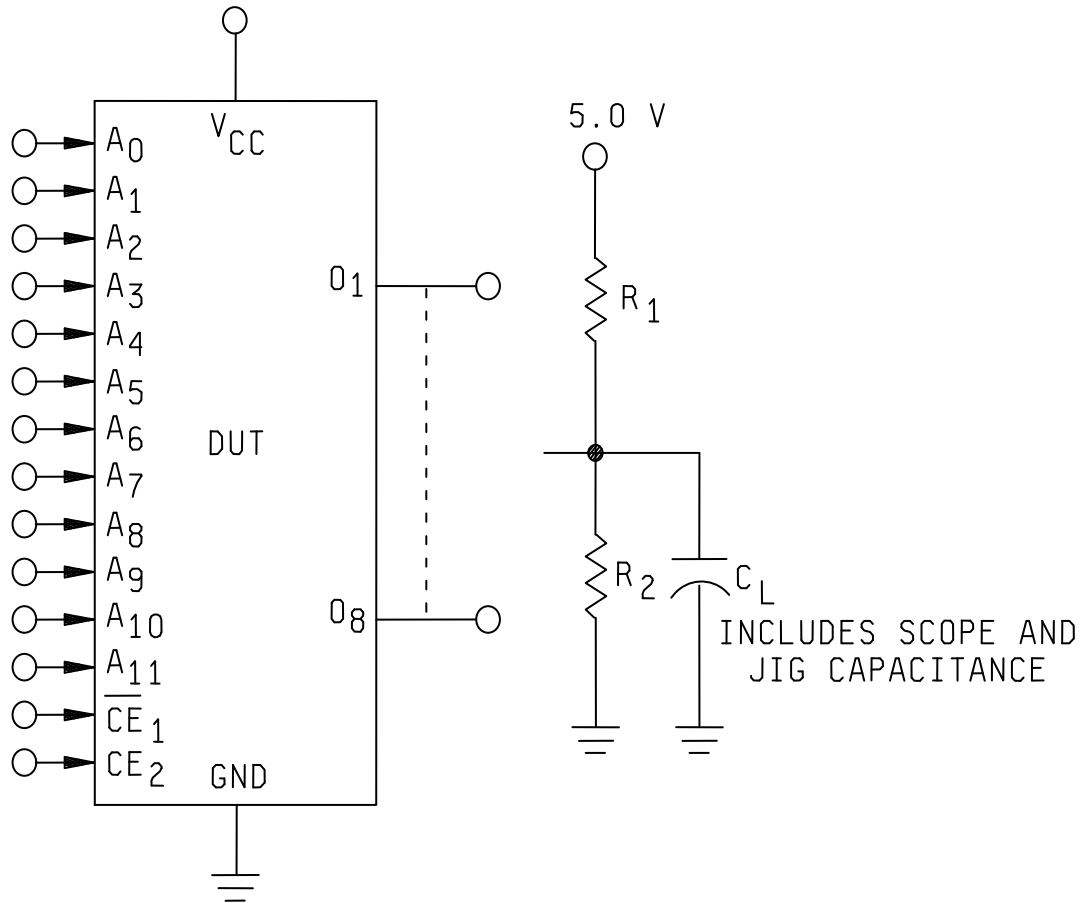

Note: $R_1 = 270\Omega$ and $R_2 = 600\Omega$ $C_L = 50$ pF

FIGURE 3. Switching time test circuits and waveforms – Continued.

**STANDARD
MICROCIRCUIT DRAWING**
DLA LAND AND MARITIME
COLUMBUS, OHIO 43218-3990

SIZE
A

82008

REVISION LEVEL
L

SHEET
9

Circuit C Continued

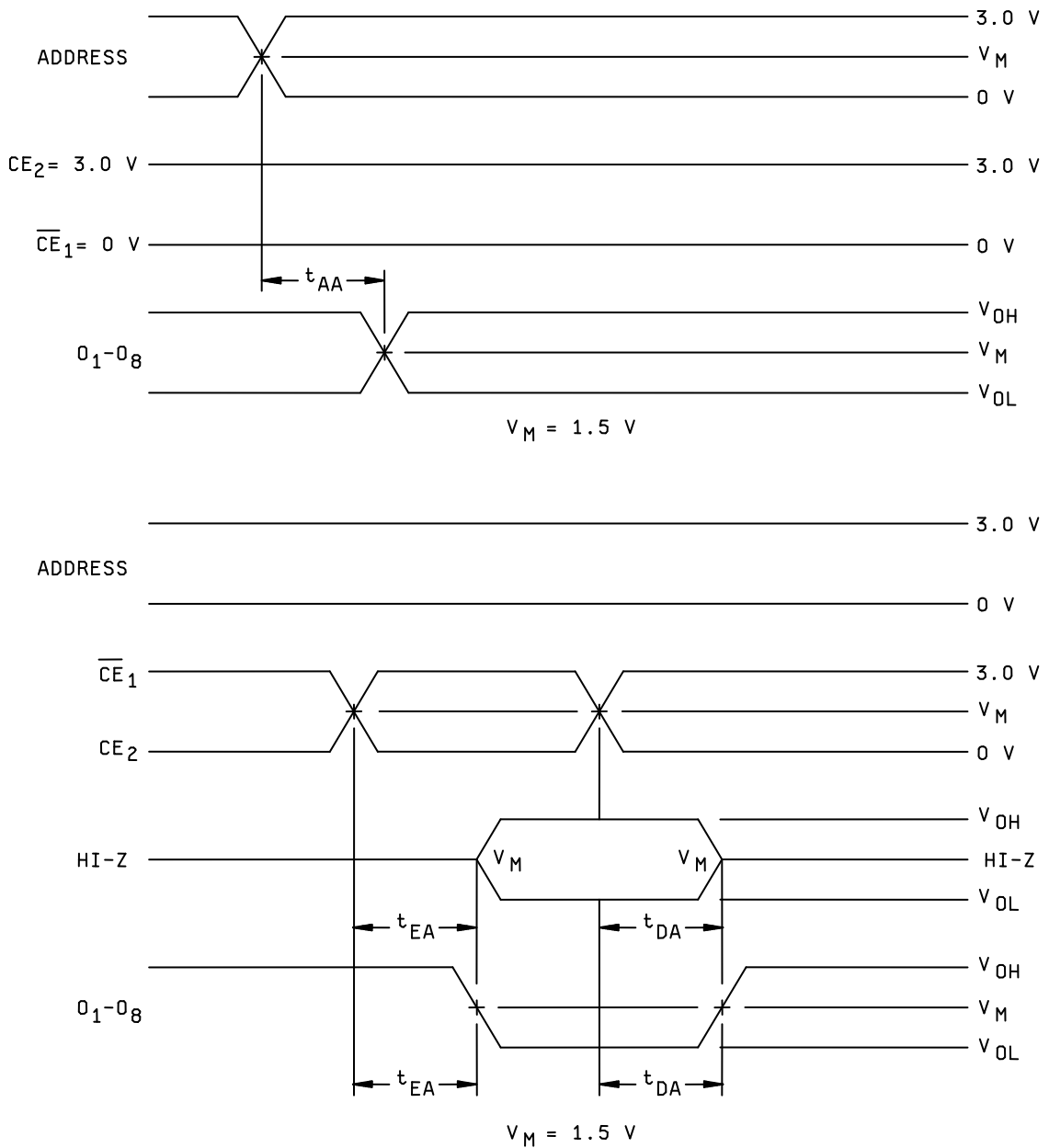

FIGURE 3. Switching time test circuits and waveforms – Continued.

**STANDARD
MICROCIRCUIT DRAWING**
DLA LAND AND MARITIME
COLUMBUS, OHIO 43218-3990

SIZE
A

82008

REVISION LEVEL
L

SHEET
10

3.3 Electrical performance characteristics. Unless otherwise specified herein, the electrical performance characteristics are as specified in table I and shall apply over the full case operating temperature range.

3.4 Electrical test requirements. The electrical test requirements shall be the subgroups specified in table II. The electrical tests for each subgroup are described in table I.

3.5 Marking. Marking shall be in accordance with MIL-PRF-38535, appendix A. The part shall be marked with the PIN listed in 1.2 herein. In addition, the manufacturer's PIN may also be marked.

3.5.1 Certification/compliance mark. A compliance indicator "C" shall be marked on all non-JAN devices built in compliance to MIL-PRF-38535, appendix A. The compliance indicator "C" shall be replaced with a "Q" or "QML" certification mark in accordance with MIL-PRF-38535 to identify when the QML flow option is used.

3.6 Certificate of compliance. A certificate of compliance shall be required from a manufacturer in order to be listed as an approved source of supply in MIL-HDBK-103 (see 6.6 herein). The certificate of compliance submitted to DLA Land and Maritime-VA prior to listing as an approved source of supply shall affirm that the manufacturer's product meets the requirements of MIL-PRF-38535, appendix A and the requirements herein.

3.7 Certificate of conformance. A certificate of conformance as required in MIL-PRF-38535, appendix A shall be provided with each lot of microcircuits delivered to this drawing.

3.8 Notification of change. Notification of change to DLA Land and Maritime-VA shall be required for any change that affects this drawing.

3.9 Verification and review. DLA Land and Maritime, DLA Land and Maritime's agent, and the acquiring activity retain the option to review the manufacturer's facility and applicable required documentation. Offshore documentation shall be made available onshore at the option of the reviewer.

3.10. Processing options. Since the device is capable of being programmed by either the manufacturer or the user to result in a wide variety of configurations; two processing options are provided for selection in the contract, using an altered item drawing.

3.10.1 Unprogrammed device delivered to the user. All testing shall be verified through group A testing as defined in 3.2.3.1 and table II. It is recommended that users perform subgroups 7 and 9 after programming to verify the specific program configuration.

3.10.2 Manufacturer-programmed device delivered to the user. All testing requirements and quality assurance provisions herein, including the requirements of the altered item drawing, shall be satisfied by the manufacturer prior to delivery.

4. VERIFICATION

4.1 Sampling and inspection. Sampling and inspection procedures shall be in accordance with MIL-PRF-38535, appendix A.

4.2 Screening. Screening shall be in accordance with method 5004 of MIL-STD-883, and shall be conducted on all devices prior to quality conformance inspection. The following additional criteria shall apply:

a. Burn-in test, method 1015 of MIL-STD-883.

(1) Test condition A, C, D, or E. The test circuit shall be maintained by the manufacturer under document revision level control and shall be made available to the preparing or acquiring activity upon request. The test circuit shall specify the inputs, outputs, biases, and power dissipation, as applicable, in accordance with the intent specified in method 1015 of MIL-STD-883.

(2) $T_A = +125^\circ\text{C}$, minimum.

b. Interim and final electrical test parameters shall be as specified in table II herein, except interim electrical parameter tests prior to burn-in are optional at the discretion of the manufacturer.

c. All devices processed to an altered item drawing may be programmed either before or after burn-in at the manufacturer's discretion. The required electrical testing shall include, as a minimum, the final electrical tests for programmed devices as specified in table II herein.

STANDARD MICROCIRCUIT DRAWING DLA LAND AND MARITIME COLUMBUS, OHIO 43218-3990	SIZE A		82008
		REVISION LEVEL L	SHEET 11

TABLE II. Electrical test requirements. 1/ 2/ 3/

MIL-STD-883 test requirements	Subgroups (in accordance with MIL-STD-883, method 5005, table I)
Interim electrical parameters (method 5004)	---
Final electrical test parameters (method 5004) for unprogrammed devices	1*, 2, 3, 7*, 8A, 8B
Final electrical test parameters (method 5004) for programmed devices	1*, 2, 3, 7*, 8A, 8B, 9
Group A test requirements (method 5005)	1, 2, 3, 4, 7, 8A, 8B, 9, 10, 11
Groups C and D end-point electrical parameters (method 5005)	1, 2, 3, 7, 8A, 8B

1/ * Indicates PDA applies to subgroups 1 and 7.

2/ Any or all subgroups may be combined when using high-speed testers.

3/ Subgroups 7 and 8 shall consist of verifying the pattern specified.

4.3 Quality conformance inspection. Quality conformance inspection shall be in accordance with method 5005 of MIL-STD-883 including groups A, B, C, and D inspections. The following additional criteria shall apply.

4.3.1 Group A inspection.

- a. Tests shall be as specified in table II herein.
- b. Subgroups 5 and 6 in table I, method 5005 of MIL-STD-883 shall be omitted.
- c. Subgroup 4 (C_{IN} and C_{OUT} measurements) shall be measured only for the initial test and after process or design changes which may affect input or output capacitance. Sample size is 15 devices with no failures, and all input and output terminals tested.
- d. Unprogrammed devices shall be tested for programmability and ac performance compliance to the requirements of group A, subgroup 9,10,11. Either of two techniques is acceptable:
 - (1) Testing the entire lot using additional built-in test circuitry which allows the manufacturer to verify programmability and ac performance without programming the user array. If this is done, the resulting test patterns shall be verified on all devices during subgroup 9,10,11 group A testing in accordance with the sampling plan specified in MIL-STD-883, method 5005.
 - (2) If such compliance cannot be tested on an unprogrammed device, a sample shall be selected to satisfy programmability requirements prior to performing subgroup 9,10,11. Twelve devices shall be submitted to programming (see 3.2.2.1). If more than two devices fail to program, the lot shall be rejected. At the manufacturer's option, the sample may be increased to 24 total devices with no more than four total device failures allowable.

Ten devices from the programmability sample shall be submitted to the requirements of group A, subgroup 9,10,11. If more than two total devices fail, the lot shall be rejected. At the manufacturer's option, the sample may be increased to 20 total devices with no more than four total device failures allowable.

- e. Subgroups 7 and 8 shall include verification of the truth table.

STANDARD MICROCIRCUIT DRAWING DLA LAND AND MARITIME COLUMBUS, OHIO 43218-3990	SIZE A		82008
		REVISION LEVEL L	SHEET 12

4.3.2 Groups C and D inspections.

- a. End-point electrical parameters shall be as specified in table II herein.
- b. Steady-state life test conditions, method 1005 of MIL-STD-883.
 - (1) Test condition A, C, D, or E. The test circuit shall be maintained by the manufacturer under document revision level control and shall be made available to the preparing or acquiring activity upon request. The test circuit shall specify the inputs, outputs, biases, and power dissipation, as applicable, in accordance with the intent specified in method 1005 of MIL-STD-883.
 - (2) $T_A = +125^{\circ}\text{C}$, minimum.
 - (3) Test duration: 1,000 hours, except as permitted by method 1005 of MIL-STD-883.

4.4 Programming procedures. The programming procedures shall be as specified by the device manufacturer.

5. PACKAGING

5.1 Packaging requirements. The requirements for packaging shall be in accordance with MIL-PRF-38535, appendix A.

6. NOTES

6.1 Intended use. Microcircuits conforming to this drawing are intended for use for Government microcircuit applications (original equipment), design applications, and logistics purposes.

6.2 Replaceability. Microcircuits covered by this drawing will replace the same generic device covered by a contractor-prepared specification or drawing.

6.3 Configuration control of SMD's. All proposed changes to existing SMD's will be coordinated with the users of record for the individual documents. This coordination will be accomplished using DD Form 1692, Engineering Change Proposal.

6.4 Record of users. Military and industrial users shall inform DLA Land and Maritime when a system application requires configuration control and the applicable SMD. DLA Land and Maritime will maintain a record of users and this list will be used for coordination and distribution of changes to the drawings. Users of drawings covering microelectronics devices (FSC 5962) should contact DLA Land and Maritime-VA, telephone (614) 692-0544.

6.5 Comments. Comments on this drawing should be directed to DLA Land and Maritime-VA, Columbus, Ohio 43218-3990, or telephone (614) 692-0540.

6.6 Approved sources of supply. Approved sources of supply are listed in MIL-HDBK-103. The vendors listed in MIL-HDBK-103 have agreed to this drawing and a certificate of compliance (see 3.6 herein) has been submitted to and accepted by DLA Land and Maritime-VA.

6.7 Circuit designator. For CAGE code and vendor association, see MIL-HDBK-103. Circuit C is 18324, and circuit F is 07933.

STANDARD MICROCIRCUIT DRAWING DLA LAND AND MARITIME COLUMBUS, OHIO 43218-3990	SIZE A		82008
		REVISION LEVEL L	SHEET 13

STANDARD MICROCIRCUIT DRAWING BULLETIN

DATE: 10-11-10

Approved sources of supply for SMD 82008 are listed below for immediate acquisition information only and shall be added to MIL-HDBK-103 and QML-38535 during the next revision. MIL-HDBK-103 and QML-38535 will be revised to include the addition or deletion of sources. The vendors listed below have agreed to this drawing and a certificate of compliance has been submitted to and accepted by DLA Land and Maritime-VA. This information bulletin is superseded by the next dated revision of MIL-HDBK-103 and QML-38535. DLA Land and Maritime maintains an online database of all current sources of supply at <http://www.dsccl.dla.mil/Programs/Smcr/>.

Standard microcircuit drawing PIN <u>1/</u> <u>2/</u>	Vendor CAGE number	Vendor similar PIN <u>3/</u>
8200801JA	<u>4/</u> <u>4/</u> <u>4/</u> <u>4/</u> 58625 0C7V7	82HS321A/BJA 53S3281J/883B AM27S43/BJA R29771DM/883B SL82HS321J1 R29771
8200801KA	<u>4/</u> <u>4/</u> <u>4/</u> 58625	82HS321A/BKA 53S3281W/883B AM27S43/BKA SL82HS321K1
8200801LA	<u>4/</u> 0C7V7	R29771SM/883B R29771
8200801XA	<u>4/</u> 0C7V7	AM27S43/BUA R29771
82008013A	<u>4/</u> <u>4/</u> <u>4/</u> <u>4/</u> 58625 0C7V7	82HS321A/B3A 53S3281L/883B AM27S43/B3A R29771LM/883B SL82HS32131 R29771
8200802JA	<u>4/</u> <u>4/</u> <u>4/</u> <u>4/</u> 58625	82HS321A/BJA 53S3281AJ/883B AM27S43A/BJA 82HS321A/BJA SL82HS321J1
8200802KA	<u>4/</u> <u>4/</u> <u>4/</u> <u>4/</u> 58625	82HS321A/BKA 53S3281AW/883B AM27S43A/BKA 82HS321A/BKA SL82HS321K1
8200802XA	<u>4/</u>	AM27S43A/BUA
82008023A	<u>4/</u> <u>4/</u> <u>4/</u> <u>4/</u> 58625	82HS321A/B3A 53S3281AL/883B AM27S43A/B3A 82HS321A/B3A SL82HS32131

See footnotes at end of listing.

STANDARD MICROCIRCUIT DRAWING BULLETIN – Continued.

Standard microcircuit drawing PIN <u>1/</u> <u>2/</u>	Vendor CAGE number	Vendor similar PIN <u>3/</u>
8200803JA	<u>4/</u> <u>4/</u> 58625 <u>4/</u>	82HS321B/BJA 53S3281BJ/883B SL82HS321J1 82HS321A/BJA
8200803KA	<u>4/</u> <u>4/</u> <u>4/</u> 58625	82HS321B/BKA 53S3281BW/883B 82HS321A/BKA SL82HS321K1
82008033A	<u>4/</u> <u>4/</u> 58625	82HS321B/B3A 53S3281BL/883B SL82HS32131
8200804JA	<u>4/</u> 0C7V7	82HS321C/BJA R29771DM/883B
8200804KA	<u>4/</u> <u>4/</u>	82HS321C/BKA R29771FM/883B
8200804LA	0C7V7	R29771SM/883B
82008043A	0C7V7 <u>4/</u>	R29771LM/883B 82HS321C/B3A

- 1/ Military drawing and DSCC drawing PINs formerly had a programming procedure letter within the military drawing PIN: these parts are interchangeable with parts that are now marked without the programming procedure letter within the military drawing number, i.e. 82008C1JA is interchangeable with 8200801JA.
- 2/ The lead finish shown for each PIN representing a hermetic package is the most readily available from the manufacturer listed for that part. If the desired lead finish is not listed contact the vendor to determine its availability.
- 3/ **Caution.** Do not use this number for item acquisition. Items acquired to this number may not satisfy the performance requirements of this drawing.
- 4/ Not available from an approved source of supply.

Vendor CAGE <u>number</u>	Vendor name <u>and address</u>	Fusible <u>link</u>
58625	Lansdale Semiconductor, Inc. 2412 W. Huntington Drive Tempe, AZ 85282-3132	anti-fuse
0C7V7	QP Semiconductor 2945 Oakmead Village Court Santa Clara, CA 95051	NiCr or Zapped vertical emitter

The information contained herein is disseminated for convenience only and the Government assumes no liability whatsoever for any inaccuracies in the information bulletin.

X-ON Electronics

Largest Supplier of Electrical and Electronic Components

Click to view similar products for [e2v manufacturer](#):

Other Similar products are found below :

[5962-89841063A](#) [M38510/06102BFA](#) [M38510/75001BCA\(NSC\)](#) [EV12DS460AMZPY](#) [5962-8764803XA](#) [M38510/10301BHA](#) [5962-8872607LA](#) [5962-9457701QLA\(NSC\)](#) [8413202RA](#) [5962-9172201MEA](#) [5962-8983901RA\(E2VLATTICE\)](#) [5962-88670023A\(CYPRESS\)](#) [5962-8751601CA](#) [5962-9174402MXA\(CYPRESS\)](#) [M38510/06202BFA](#) [M38510/10107BHA\(LTC\)](#) [5962-9080308MKA](#) [5962-9218701M2A\(E2VNSC\)](#) [5962-9062007MXA](#) [M38510/10304BCA](#) [5962-8867004LA\(E2VCYPRESS\)](#) [585R727H06](#) [5962-8873502LA\(ST\)](#) [M38510/11302BEA\(FSC-RAY\)](#) [8602501YA](#) [5962-8968801EA\(E2VNSC\)](#) [M38510/33401B2A\(NSC\)](#) [5962-88734033A\(ST\)](#) [5962-9682901Q2A\(NSC\)](#) [5962-8752902LA\(ST\)](#) [5962-9469601MFA\(E2VNSC\)](#) [5962-87760012A\(E2VNSC\)](#) [M38510/00302BCA](#) [M38510/00302BCA\(E2VNSC\)](#) [5962-89841043A\(CYPRESS\)](#) [5962-87515033C\(ST\)](#) [5962-9154507MXA](#) [M38510/10305BFA](#) [5962-9161708MYA](#) [5962-8871310RA](#) [5962-8765001KA\(ST\)](#) [5962-9172201MFA\(NSC\)](#) [M38510/10304BHA\(FSC-RAY\)](#) [QP27C256L-120/XIA](#) [QP82S100/BYA-MIL](#) [5962-8955201FA\(NSC\)](#) [M38510/10802BCA](#) [5962-8873503LA](#) [5962-8873503LA\(E2VST\)](#) [5962-8851806LA](#)