

TERMINAL

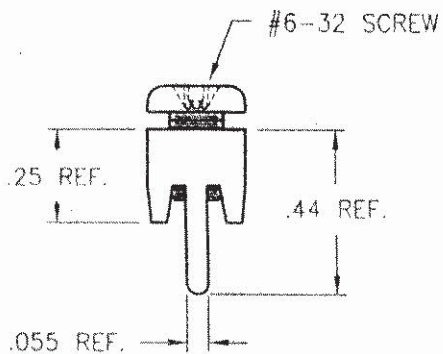

BILL OF MATERIAL

PART NUMBER	SCREW NUMBER	TERMINAL NUMBER
1011-00	NO SCREWS	1011
1011-02	F508 (STEEL SCREW)	1011
1011-03	F510 (STL. ST. SCREW)	1011
1011-04	F509 (BRASS SCREW)	1011
1011-07	F522 (ST. SEMS SCREW)	1011

NOTES:

1. SCREW TO BE ASSEMBLED AS SHOWN STANDING ABOVE THE TERMINAL PAD. THE SCREW HEIGHT DISTANCE CAN VARY.
2. LABEL #1A9431J PRINTED PER SPECIFICATION #1P2182

PART NO. 1011-XX		PLANT DISTRIBUTION CODE J U	
REV #	REVISIONS	DATE	APPR
1	ADDED NOTE 1 * REV'D DWG TO SHOW SCREW STANDING ABOVE TERMINAL PAD ECN-D5728 UF	6-10 1997	
A	ADDED ROHS #1P2163 & PRINT SPEC #1P2182 ECN-SB06323 CEM	1-8 2007	

Product must comply with RoHS Specification #1P2163

TOLERANCES UNLESS OTHERWISE SPECIFIED		THIRD ANGLE PROJECTION	DESIGN UNITS
METRIC TOL	ENGLISH TOL		ENGLISH (in)
1 PL DEC. = ±0.25	2 PL DEC. = ±0.1	ANGULAR TOL = ±2'	CREATED USING
2 PL DEC. = ±0.13	3 PL DEC. = ±0.005	FRACTION TOL = ±1/64 IN	AUTOCAD

COPYRIGHT — Cooper Industries, Inc.

This is an unpublished work. The disclosure of this work is limited to a select personnel. Further dissemination or disclosure to the public is PROHIBITED. This unpublished work is protected by Federal Copyright Law and all rights thereunder are reserved by Cooper Industries, Inc.

CONFIDENTIAL —

The information contained in this document is the property of Cooper Industries, Inc. It is not for public disclosure. Possession of the information does not convey any right to loan, sell or disclose the information. Unauthorized reproduction or use of the information is PROHIBITED. This document is to be returned to Cooper Industries, Inc. upon completion of the purpose for which it is loaned or upon request.

MATERIAL:		USED ON:	
FINISH:		DRAWN BY:	
		RF	
		DATE:	
		5-30-97	
FILE:		U/F NO.	SCALE
		73285	2:1

COOPER Bussmann

St. Louis, MO 63178

INDEPENDENT CIRCUIT BOARD — TERMINAL ASSY.

PART NO. 1011-XX	SHT 1 OF 1	SIZE A
----------------------------	------------	------------------

X-ON Electronics

Largest Supplier of Electrical and Electronic Components

Click to view similar products for [Fuse Holder Accessories](#) category:

Click to view products by [Eaton](#) manufacturer:

Other Similar products are found below :

[BK/1A1337](#) [1A1853](#) [1A4421](#) [1A5220](#) [903-048](#) [1A1337](#) [1A4544](#) [1A5220-01](#) [CO2-10](#) [CO3-03](#) [348897](#) [B072-7007](#) [BK/1A4421](#) [X30110](#)
[09030012H](#) [09050023H](#) [00970021HXNVDL](#) [00BS0232P](#) [CO2-04](#) [BK1A1853](#) [BK9834](#) [00970053XP](#) [3566C](#) [00970053H](#) [04450718ZX900](#)
[CH10CL](#) [BP/FP-3](#) [58600000005](#) [33-012C](#) [880140](#) [00970023S](#) [880150](#) [PDM71009ZXM](#) [B109-7091-4](#) [B109-7091-6](#) [B109-7091-5](#)
[CFBAR2-M8XSP](#) [901-524](#) [CVR-RH-25100](#) [LFH60030FBC](#) [03540514Z](#) [03540526Z](#) [03540531Z](#) [03540541Z](#) [03540525Z](#) [03540537Z](#)
[03540539Z](#) [03540540Z](#) [FEH](#) [CC2/J](#)