

ATC® Circuit Breakers

Auto & Modified Reset Circuit Breakers

Series 220

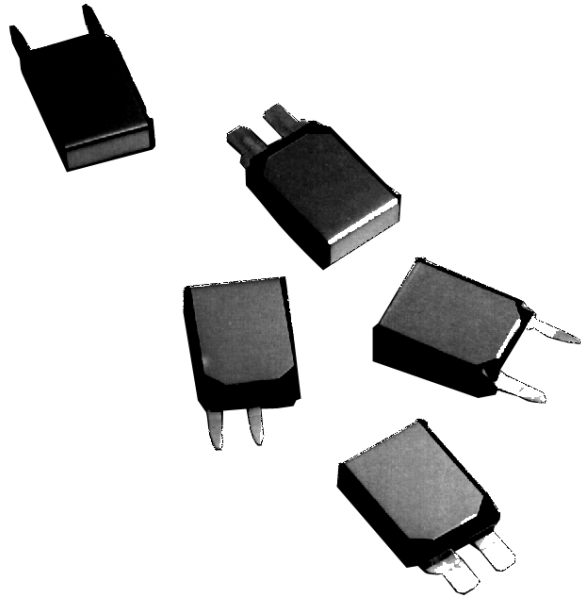

Series 220 ATC®
Auto & Modified Reset Circuit Breakers

SPECIFICATIONS

Single Pole Thermal Type Breakers

Ratings: 10A, 15A, 20A, 25A, 30A; Voltage of 14VDC.

Operating Temperature: -40°F (-40°C) to 185°F (85°C).

Storage Temperature: -40°F (-40°C) to 260°F (125°C).

Cover: Gray plastic housing with standard gold cover (Type I) or silver cover (Type II).

Marking: Standard marking includes amp/volt ratings, part number, and date code.

Termination Type: Compatible with 280 Type or ATC fuse blocks.

Approvals: Complies with the requirements of SAE standard J553 Type I and Type II Circuit Breakers.

Dimensions

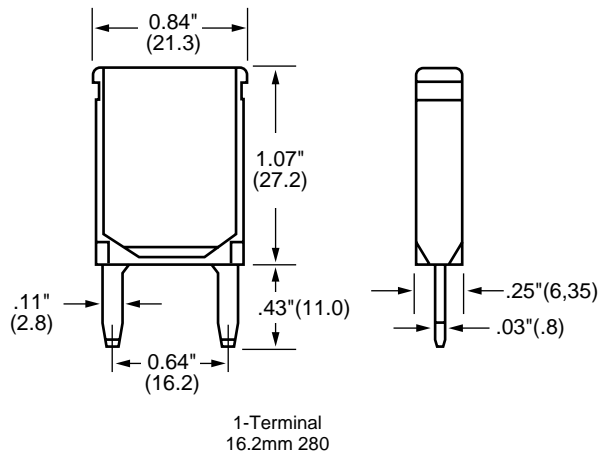

Terminal Options

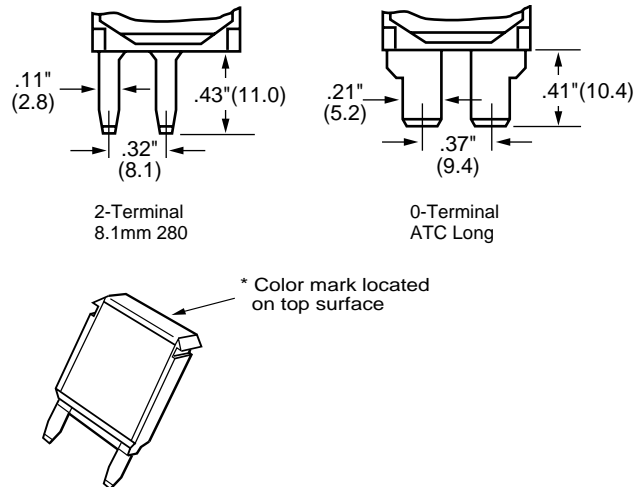

PART NUMBERING SYSTEM

Series



221 – Type I, 14VDC
222 – Type II, 14VDC

Rating*



10 – 10 amps (Red)
15 – 15 amps (Blue)
20 – 20 amps (Yellow)
25 – 25 amps (White)
30 – 30 amps (Green)

Terminal



0 – ATC Long Terminal
1 – 16.2mm 280 Terminal
2 – 8.1mm 280 Terminal

Marking



00 – Std. Marking
(Consult factory for Special Options.)

Special Options



Consult factory for Special Options.

The only controlled copy of this BIF document is the electronic read-only version located on the Bussmann Network Drive. All other copies of this BIF document are by definition uncontrolled. This bulletin is intended to clearly present comprehensive product data and provide technical information that will help the end user with design applications. Bussmann reserves the right, without notice, to change design or construction of any products and to discontinue or limit distribution of any products. Bussmann also reserves the right to change or update, without notice, any technical information contained in this bulletin. Once a product has been selected, it should be tested by the user in all possible applications.

X-ON Electronics

Largest Supplier of Electrical and Electronic Components

Click to view similar products for [Circuit Breakers](#) category:

Click to view products by [Eaton](#) manufacturer:

Other Similar products are found below :

[0185080.X](#) [0185100.XP](#) [0185150.XP](#) [0700005](#) [0700007](#) [0700010](#) [0700015](#) [0700020](#) [0700025](#) [0700030](#) [0700040](#) [0712107](#) [0712123](#)
[0712152](#) [0712194](#) [0712217](#) [0712233](#) [0712259](#) [0712275](#) [0712291](#) [0712314](#) [0900100](#) [0900113](#) [0900126](#) [0900207](#) [0900210](#) [0900317](#)
[0900333](#) [0900414](#) [0900618](#) [0900634](#) [0900812](#) [0901002](#) [0902030](#) [0902056](#) [0902072](#) [0902098](#) [0902108](#) [0902111](#) [0902124](#) [0902137](#)
[0902218](#) [0902221](#) [0902247](#) [0902263](#) [0902328](#) [0902331](#) [0902344](#) [0902409](#) [0902412](#)