

AGC

1/4" x 1-1/4" Fast-acting glass tube fuses



Product features

- Fast-acting
- Optional axial leads available
- 1/4" x 1-1/4" (6.3 mm x 32 mm) physical size
- Glass tube, nickel-plated brass end cap construction
- UL Listed product meets standard 248-14

Applications

Primary circuit protection

- Power supplies
- Battery chargers
- Monitors
- Consumer electronics
- Test equipment

Agency information

- UL Listed card: File E19180, Guide JDYX (AGC 1/10 A - 10 A)
- UL Recognition card: File E19180, Guide JDYX2 (AGC 11 A - 40 A)
- CSA Component acceptance card (Class No. 1422-30)
- CSA Certification acceptance card (Class No. 1422-01)

Ordering code

The ordering code is the part number replacing the "/" with a "-" plus adding the packaging prefix and option code.

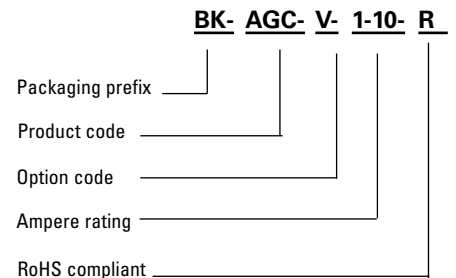

Packaging prefix

- Blank (5 ferrule/cartridge parts in a 5 inch tin, 4 axial lead parts in a 5 inch tin)
- BK- (100 parts packed into a cardboard carton with flaps folded)

Option code

- -B- (Board washable - Hermetically sealed to withstand aqueous cleaning)
- -V- (Axial leads - copper tinned wire with nickel-plated brass end caps)



Powering Business Worldwide

Electrical characteristics

Amp Rating	% of Amp Rating	Opening Time
1/10 A – 40 A	100%	4 hours minimum
1/10 A – 40 A	135%	60 minutes maximum
1/10 A – 40 A	200%	120 seconds maximum

Product specifications

Part Number	Current rating (A)	Voltage rating (Vac)	AC Interrupting rating (A)			Typical DC cold resistance ¹ (Ω)	Typical melting I ² t (A ² s)	Typical voltage drop ³ (V)
			250 V	125 V	32 V			
AGC-1/10-R	0.1	250	35	10,000	1000	17.55	0.0010	15.168
AGC-1/8-R	0.125	250	35	10,000	1000	10.825	0.0020	10.854
AGC-3/16-R	0.1875	250	35	10,000	1000	6.050	0.0070	7.652
AGC-2/10-R	0.5	250	35	10,000	1000	4.800	0.0080	6.105
AGC-1/4-R	0.25	250	35	10,000	1000	1.550	0.0160	0.984
AGC-3/10-R	0.3	250	35	10,000	1000	1.084	0.0270	0.886
AGC-3/8-R	0.375	250	35	10,000	1000	0.703	0.0900	0.548
AGC-1/2-R	0.5	250	35	10,000	1000	0.483	0.3850	0.324
AGC-3/4-R	0.75	250	35	10,000	1000	0.272	1.7160	0.309
AGC-1-R	1.0	250	35	10,000	1000	0.167	3.2400	0.256
AGC-1-1/4-R	1.25	250	100	10,000	1000	0.122	5.0940	0.222
AGC-1-1/2-R	1.5	250	100	10,000	1000	0.077	9.0230	0.218
AGC-2-R	2.0	250	100	10,000	1000	0.063	17.520	0.199
AGC-2-1/4-R	2.25	250	100	10,000	1000	0.052	22.832	0.194
AGC-2-1/2-R	2.5	250	100	10,000	1000	0.045	28.688	0.193
AGC-3-R	3.0	250	100	10,000	1000	0.035	45.900	0.191
AGC-4-R	4.0	250	200	10,000	1000	0.024	86.560	0.179
AGC-5-R	5.0	250	200	10,000	1000	0.019	131.500	0.170
AGC-6-R	6.0	250	200	10,000	1000	0.015	144.360	0.165
AGC-7-R	7.0	250	200	10,000	1000	0.012	195.02	0.159
AGC-7-1/2-R	7.5	250	200	10,000	1000	0.012	216.00	0.155
AGC-8-R	8.0	250	200	10,000	1000	0.009	256.00	0.152
AGC-9-R	9.0	250	200	10,000	1000	0.009	395.28	0.148
AGC-10-R	10	250	200	10,000	1000	0.008	486.00	0.141
AGC-12-R	12	32	—	—	1000	0.006	696.96	0.138
AGC-14-R	14	32	—	—	1000	0.005	776.16	0.132
AGC-15-R	15	32	—	—	1000	0.005	807.75	0.128
AGC-20-R	20	32	—	—	1000	0.0034	2440.00	0.125
AGC-25-R	25	32	—	—	1000	0.0027	3875.00	0.120
AGC-30-R	30	32	—	—	1000	0.0024	4950.00	0.135
AGC-35-R	35	32	—	—	1000	0.0021	7350.00	0.130
AGC-40-R	40	32	—	—	1000	0.0016	11360.00	0.125

1. DC cold resistance measured at <10% of rated current
2. Typical melting I²t measured at listed interrupting rating and rated voltage
3. Typical voltage drop measured at +25 °C and rated current

Dimensions—mm

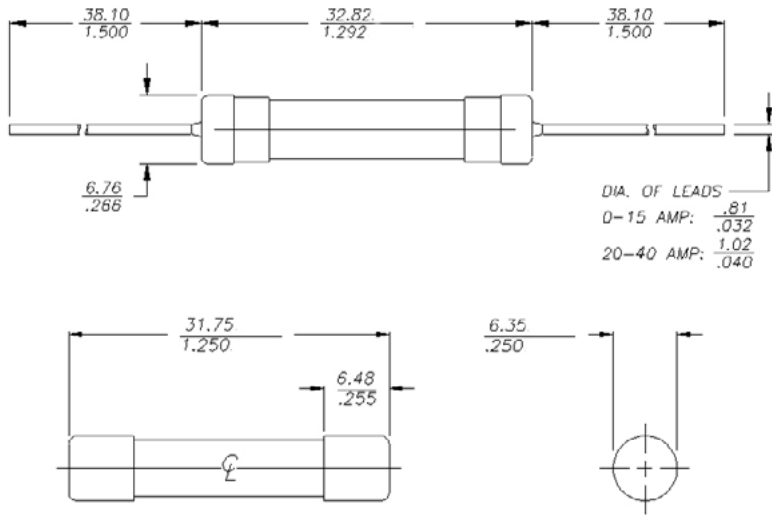

Temperature derating curve

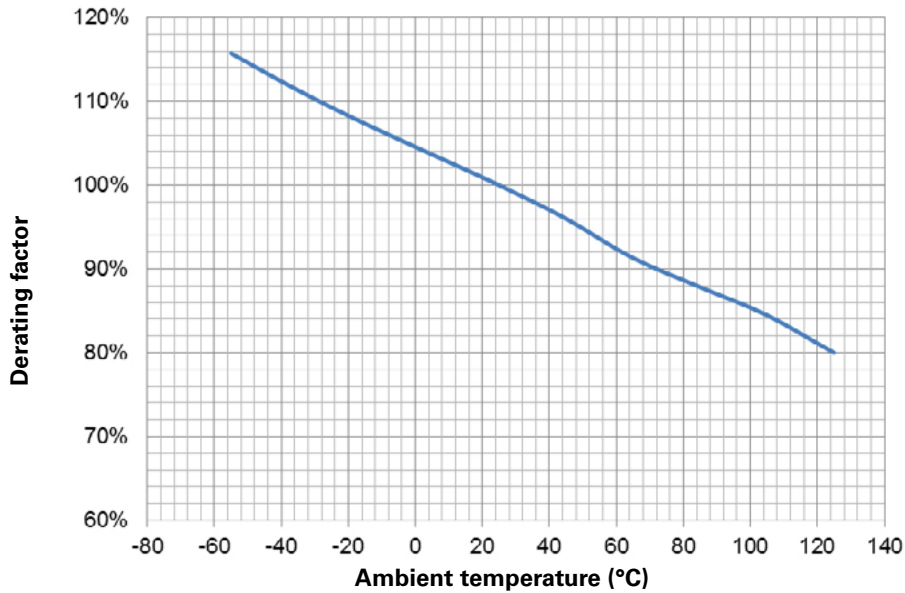

General specifications

Operating temperature: -55 °C to +125 °C (with derating)

Shock: 1/10 A to 3/4 A, MIL-STD-202, Method 213, Test Condition I
 1 A to 30 A, MIL-STD-202, Method 207, (HI Shock)

Vibration: 1/10 A to 30 A MIL-STD-202, Method 204, Test Condition A (Except 5f, 500HZ)

Time current curve

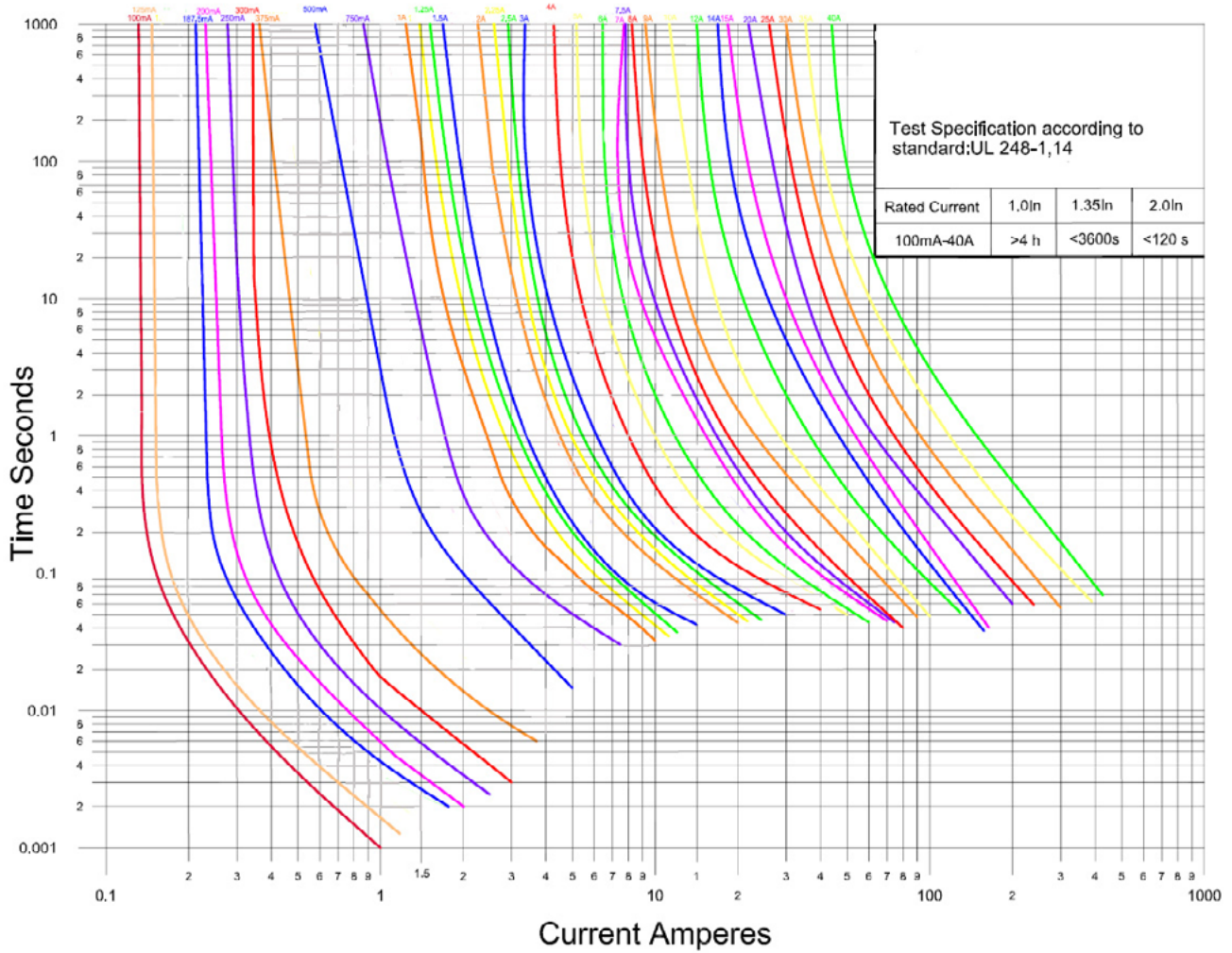

Wave solder profile (Axial lead only)

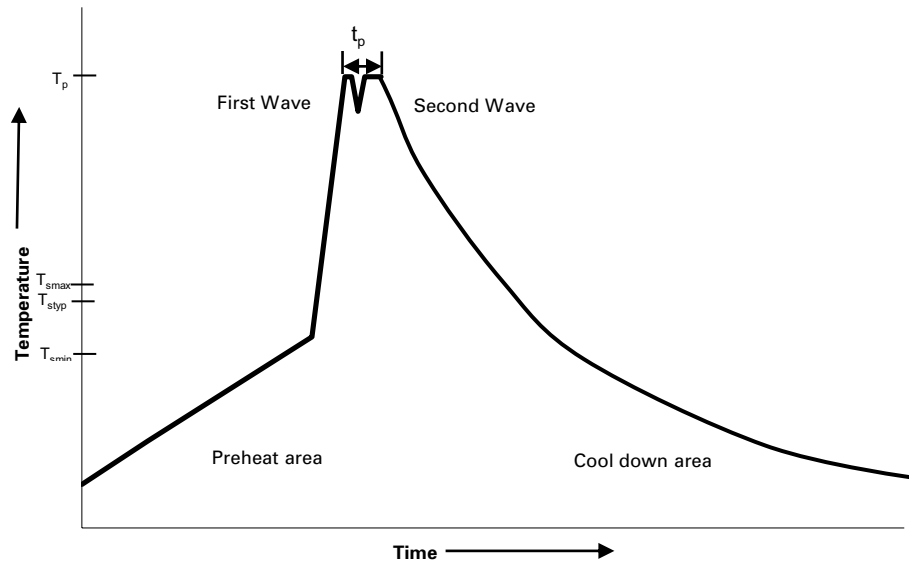

Reference EN 61760-1:2006

Profile feature	Standard SnPb solder	Lead (Pb) free solder
Preheat		
• Temperature min. (T_{smin})	100 °C	100 °C
• Temperature typ. (T_{styp})	120 °C	120 °C
• Temperature max. (T_{smax})	130 °C	130 °C
• Time (T_{smin} to T_{smax}) (t_s)	70 seconds	70 seconds
Δ preheat to max Temperature	150 °C max.	150 °C max.
Peak temperature (T_p)*	235 °C – 260 °C	250 °C – 260 °C
Time at peak temperature (t_p)	10 seconds max 5 seconds max each wave	10 seconds max 5 seconds max each wave
Ramp-down rate	~ 2 K/s min ~3.5 K/s typ ~5 K/s max	~ 2 K/s min ~3.5 K/s typ ~5 K/s max
Time 25 °C to 25 °C	4 minutes	4 minutes

Manual solder

+350 °C (4-5 seconds by soldering iron), generally manual/hand soldering is not recommended

Life Support Policy: Eaton does not authorize the use of any of its products for use in life support devices or systems without the express written approval of an officer of the Company. Life support systems are devices which support or sustain life, and whose failure to perform, when properly used in accordance with instructions for use provided in the labeling, can be reasonably expected to result in significant injury to the user.

Eaton reserves the right, without notice, to change design or construction of any products and to discontinue or limit distribution of any products. Eaton also reserves the right to change or update, without notice, any technical information contained in this bulletin.

Eaton
Electronics Division
1000 Eaton Boulevard
Cleveland, OH 44122
United States
Eaton.com/electronics

© 2020 Eaton
All Rights Reserved
Printed in USA
Publication No. 2543 BU-MC20075
April 2020

Eaton is a registered trademark.

All other trademarks are property of their respective owners.

Follow us on social media to get the latest product and support information.



X-ON Electronics

Largest Supplier of Electrical and Electronic Components

Click to view similar products for [Cartridge Fuses](#) category:

Click to view products by [Eaton](#) manufacturer:

Other Similar products are found below :

[5TT3A-R](#) [MBO-20](#) [MDM-4/10](#) [MDQ-V-15/100](#) [MDX-1-6/10](#) [MDX-2](#) [MDX-3-2/10](#) [MDX-6-1/4](#) [FLSR-15](#) [FLSR-30](#) [FRS-1-1/4](#) [FRS-1-6/10](#) [FRS-4/10](#) [H362003](#) [ABC-2](#) [1/2A](#) [12C10X38GI](#) [AGC-1-1/2RX](#) [AGC-15EX](#) [AGC-V-3-12-R](#) [AGY-50](#) [15019-G](#) [MSL-1-1/2](#) [MSL-1-1/4](#) [MSL-1/2](#) [MSL-1/4](#) [MSL-3](#) [MSL-3/4](#) [MSL-4](#) [MSL-5](#) [BK1/C436-2A](#) [BK1-GMA-1-6-R](#) [BK1-S505-1-R](#) [BK1-S506-3-15-R](#) [BK/MDM-15](#) [BK/MDM-3/4](#) [S501-V-10A](#) [S505-V-500MA](#) [SEF-1697-1-002](#) [301030](#) [303030](#) [FLA10](#) [FLA-4/10](#) [FLNR-5](#) [20.0M6.3X32F](#) [GBB-17-1/2](#) [301001](#) [301020](#) [311008](#) [313.25](#)