

Application note
Compact Circuit Protector (CCP2)

BUSSMANN
SERIES



**Smaller, better...
the Power of Space**

EATON

Powering Business Worldwide

Table of contents

Description	Page
Introduction, features and benefits	3
Product and accessory overview	4-5
General disconnect and overcurrent protection considerations	6
Comparison - fusible solutions	6
Footprint comparisons with traditional fusible rotary switches	7
Comparison - circuit breaker solutions	8
Main disconnect applications	9
Sizing main disconnect fuses	9
Main disconnect comparisons	9
Motor circuit solution comparison	10
Motor branch circuit applications	11
Power electronics solution comparison	12
Power electronics applications	13
Resistive heating and lighting circuit applications	14-15
Control circuit applications	16
Applying CCP2 accessories	17
PLC fuse monitor	17
Auxiliary contact	17
Multi-wire lug kits and shrouds	18
Selector and pistol handles	18
Flange handles	18
NFPA 79 handle	18
Common misapplications in industrial control panels	19-21
Other applications using CCP2	22
Fuse selection	23
Transformers protection	23
Motor branch circuit protection	24-25



UL Class CF branch circuit CUBEFuse — now available up to 400 A

The CUBEFuse was first introduced in 2000 and stands in a class by itself, UL 248 Class CF. The original design was conceived from customer feedback to provide the benefits of the Busmann series Low-Peak Dual-Element Time-Delay Class J fuse, but in a smaller, finger-safe package. Over the last two decades, the CUBEFuse has evolved from a non-indicating 30 A fuse and fuse holder, to a full-range offering with indication up to 400 A. Millions of these fuses have been installed and they are readily available on distributor shelves across North America.

The CUBEFuse achieves the smallest footprint of any UL Class J, R or T fusible solution — requiring up to 70% less space while delivering a total benefits package including:

- Finger-safe, plug-in capability makes installation and replacement easier and safer
- High interrupting ratings, up to 300 kA — can safely interrupt the highest fault currents
- Excellent current limitation helps to achieve high short-circuit current ratings for devices and assemblies and reduce arc flash hazards when properly applied
- Ease of selective coordination in an all fused system using published amp ratios or with upstream Eaton circuit breakers eliminating unnecessary power outages
- Saves space when used with fuse holders or CCP2 switches and available in panelboards

Why SCCR is important

Short-circuit current rating (SCCR) is an equipment rating pertaining to safety under fault current conditions. Failure to apply equipment SCCRs properly can result in serious safety hazards including shock, fire and projectiles (shrapnel). Both the NEC and OSHA SCCR requirements prohibit locating equipment at any point in an electrical system where the available fault current is greater than what the equipment can withstand. This applies to new and existing installations, as well as equipment that's moved within a single or multiple facilities.

Overcurrent protective devices play a key role in equipment SCCR. Their interrupting rating, the ability of the overcurrent device to safely interrupt the fault, affects the assembly's maximum SCCR. High interrupting ratings (IR) help achieve high assembly SCCRs, such as Busmann series Low-Peak fuses with up to 300 kA IR along with their current-limiting ability which often results in component high fault SCCR. The CCP2 has a 200 kA SCCR that greatly aids in achieving very high equipment SCCRs.

For more information on SCCR and the 2017 NEC, see the Busmann SPD handbook and the 2017 NEC Code change booklet.



Compact Circuit Protector (CCP2)

Introduction

This application note explains the Bussmann series Compact Circuit Protector's (CCP2) use and application in equipment such as industrial control panels, industrial machinery and HVAC equipment. The CCP2 is a fusible disconnect switch featuring the industry's smallest footprint.

The CCP2 is available in three basic variations:

- Class CC fuse
- Class CF CUBEFuse
- UL Supplemental or IEC 10x38

There are many possible considerations for selecting a disconnecting means and overcurrent protection for industrial control panel applications.

The most important considerations depend upon the specific application for initial and possible future installations.

The CCP2 offers:

- Enhanced short-circuit current ratings (SCCR) up to 200 kA
- High interrupting ratings (IR), up to 300 kA
- Superior component protection
- Improved reliability
- Application flexibility with rotary operators and accessories
- Smaller size compared to traditional rated fusible switches
- Lower cost and similar size compared to equivalent molded case circuit breakers

For an overview of important UL and code limitations for some industrial control devices, please see "Common misapplications in industrial control panels" on page 19.

For industrial control applications, the CCP2 is the smaller, simpler, better solution as shown in Table 1.

Table 1 — Features and benefits of the CCP2

Attribute	Features	Benefits
Smaller	<ul style="list-style-type: none"> • Up to 69% smaller footprint than traditional fused disconnects • 33% smaller footprint than equivalent rated industrial molded case circuit breaker up to 100 A 	<ul style="list-style-type: none"> • Space-saving design for reduced cost
	All versions	
	<ul style="list-style-type: none"> • DIN-Rail mounted up to 100 A • Local open-fuse indication • Load-break disconnect rated • Lockout/tagout provisions • Finger-safe - IP20 compliant with 10 AWG or larger conductors 	<ul style="list-style-type: none"> • Installation ease • Maintenance ease • Disconnecting means, isolation of equipment and enhanced safety
	CCP2-Class CC or CCP2-Class CF CUBEFuse	
Simpler	<ul style="list-style-type: none"> • UL 98 Listed and cULus to Canadian Standard 22.2 No. 4-04 • Horsepower rated • 2- and 3-pole 30 A Class CC version and 30 to 400 A Class CF CUBEFuse version straight voltage rated up to 600 Vac 	<ul style="list-style-type: none"> • Suitable for use on main, feeder, branch and motor circuits • Suitable for use on any low voltage AC system (solidly grounded, resistance grounded, corner grounded or ungrounded)
	<ul style="list-style-type: none"> • 200 kA SCCR • Accepts only Class CC fuses or CUBEFuses 	<ul style="list-style-type: none"> • Highest possible SCCR • Rejects fuses with lower voltage and interrupting ratings
	<ul style="list-style-type: none"> • Excellent current-limiting overcurrent protection 	<ul style="list-style-type: none"> • Increased component SCCR combination ratings, helps reduce arc flash hazard
	<ul style="list-style-type: none"> • Up to 125 Vdc 	<ul style="list-style-type: none"> • Greater application flexibility
	CCP2-10x38	
	UL	
	<ul style="list-style-type: none"> • 30 A, 240 Vac or less (voltage and SCCR varies with installed midjet fuse) • UL 508 Listed and cULus manual motor controller 	<ul style="list-style-type: none"> • Flexibility of use for IEC applications or UL supplemental protection applications
	<ul style="list-style-type: none"> • IEC 60947-3 AC-23A with 32 A aM or 25 A gG IEC fuse 	
Better	<ul style="list-style-type: none"> • Higher ratings: voltage, interrupting and SCCR • Increased component protection 	<ul style="list-style-type: none"> • Ease of design, flexibility of use and reduced misapplications • Enhanced safety and equipment SCCR
	<ul style="list-style-type: none"> • Accessories — auxiliary contacts, PLC fuse monitor, multi-wire lugs, rotary operators, NFPA 79 handles 	<ul style="list-style-type: none"> • Ease of identification of switch and/or fuse status • Space savings (eliminates separate PDB) • Through-door and through-side operation • Code compliance

Product overview

Switches

Class CC and UL Supplemental/IEC 10x38

600 Vac, 30 A



Switch only

- 1-, 2-, 3-pole



Front rotary

- Right or left side
- Through-door operation
- 2-, 3-pole



Side rotary

- Right or left side
- Through-side operation
- 2-, 3-pole

Class CF CUBEFuse

600 Vac, 30 A, 60 A, 100 A



Switch only

- 1-, 2-, 3-pole



Front rotary

- Right or left side
- Through-door operation
- 2-, 3-pole



Side rotary

- Right or left side
- Through-side operation
- 2-, 3-pole

Class CF CUBEFuse

600 Vac, 200 A, 400 A



Switch only

- 1-, 2-, 3-pole



Front rotary

- Through-door operation
- 3-pole only
- Requires front rotary accessories:
 - CCP2-RM2 (200 A switches)
 - CCP2-RM4 (400 A switches)



Side rotary

- Right or left side
- Through-side operation
- 1-, 2-, 3-pole
- Requires side rotary accessory CCP2-SM (200 A and 400 A switches)

Accessories

Handles, selector, pistol, NFPA 79, flange cable and rod



- Red/yellow
- Black/gray



Multi-wire lug kits for 30/60 and 100 A switches



- 3-port, 60 A for switches up to 60 A
- 6-port, 100 A for 100 A switches

PLC fuse monitor for 30/60 and 100 A switches

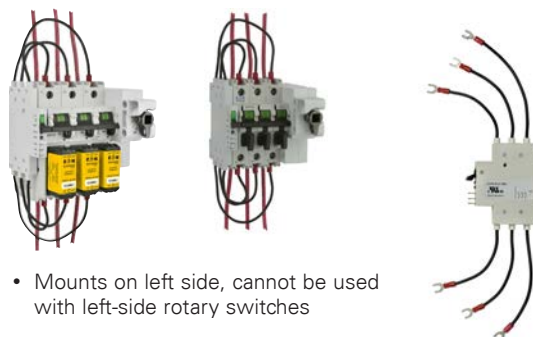

- Mounts on left side, cannot be used with left-side rotary switches

Auxiliary contacts



- CCP2-AUX and CCP2-AUX-100 mounts on right side, cannot be used with right-side rotary switches



- CCP2-AUX-S for 200 and 400 A switches mounts on right or left side

Front and side rotary mechanisms



- CCP2-RM2 (200 A switches) and CCP2-RM4 (400 A switches) front rotary mechanisms mount on only 3-pole switches



- CCP2-SM side rotary mechanism can be mounted on 1-, 2- and 3-pole versions of both the 200 and 400 A switches

Lugs and multi-wire lug kits for 200 and 400 A switches



- Available as single lugs or in kits for three pole switches, there are a variety of options to meet many conductor termination needs including copper and copper/aluminum combinations, plus multi-port lugs for power distribution purposes (see data sheet 10801 for details)

Terminal extensions and spreaders for 400 A switches



- CCP2-TE6 (terminal extension) and CCP2-TS6 (terminal spreader) provide a convenient means of connecting the 400 A switch to a busbar system in a panelboard or switchboard application

Phase barrier and shroud kits for 200 and 400 A switches

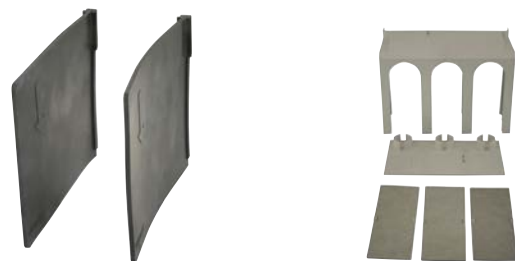

- CCP2-PB2 and CCP2-PB6 (phase barriers), and CCP2-TS2-3 and CCP2-TS6-3 (shroud kits) provide a convenient means of improving electrical safety

Handle extension for 200 and 400 A switches



- CCP2-HEX provides a convenient means of gaining mechanical advantage for operating 1-, 2- or 3-pole switches in non-rotary installations

General disconnect and overcurrent protection considerations:

The CCP2 switches with either Class CC or Class CF CUBEFuse fuses provide simple, compact, cost-effective solutions with reliable overcurrent protection and load-break disconnect capabilities not possible with fuse holders, other fusible switches or mechanical overcurrent devices. CCP2 fusible switches have high short-circuit current ratings and provide an easy, low-cost means to attain high assembly short-circuit current ratings.

Comparison — fusible solutions:

UL 98 switches can be used for branch circuit disconnects, motor branch circuit disconnects (if Hp rated), motor controllers, or within sight motor disconnects. The CCP2 is very versatile since it is the smallest, most cost effective UL 98 branch circuit disconnect with integral branch circuit rated overcurrent protection.

- Compared to other Class CC or J fusible UL 98 switches, the CCP2 has the same ratings and capabilities, but with a smaller footprint and lower cost with optional through-the-door and through-the-side rotary operation.
- The CCP2 can replace Class CC or J fuse holders with the added benefit of a HP rated disconnecting means capability.
- It can be used to replace a UL 508 switch (marked manual motor controller) combined with fuses providing a motor circuit disconnect.

Table 2 illustrates an application comparison of various fusible solutions.

Bold red text indicates device limitations.

Table 2 — CCP2 compared to fuse holder, disconnect with fuses, and fusible disconnects

	UL 98 CCP2 with Class CC or CF CUBEFuse fuses	UL 4248 Class CC or CF CUBEFuse holder	UL 98 non-fused disconnect with UL 4248 Class CC or CF CUBEFuse holder	UL 489 molded case switch with UL 4248 Class CF CUBEFuse holder	UL 98 Class CC or J disconnect
Visual reference					
See foot print comparison section for relative size					
Feeder circuit disconnect	Yes	No	Yes	Yes	Yes
Feeder circuit overcurrent protection	Yes	Yes	Yes	Yes	Yes
Branch circuit disconnect	Yes	No	Yes	Yes	Yes
Branch circuit overcurrent protection	Yes	Yes	Yes	Yes	Yes
Within sight motor circuit disconnect	Yes	No	Yes	Yes	Yes
Cost†	\$\$—\$\$\$	\$—\$\$	\$\$\$*	\$\$\$\$	\$\$\$—\$\$\$\$

* CUBEFuse with fuse holder could be used in place of Class CC fuse holder with Class CC fuses at additional cost.

† Cost includes product, space and labor.

CCP2 footprints compared to traditional fusible rotary switches

30 A Class CC

43% smaller footprint



100 A Class J

51% smaller footprint



200 A Class J

69% smaller footprint



400 A Class J

46% smaller footprint



Comparison - circuit breaker solutions

The CCP2 UL 98 fused disconnects can replace low interrupting rated circuit breakers, or misapplied supplementary protectors in branch circuit applications while providing the benefit of easily attaining a higher assembly short-circuit current rating (SCCR) at a similar or lower cost.

The CCP2 is a cost-effective solution that is similar in size to a supplementary protector or miniature circuit breaker, but offers higher voltage and interrupting ratings while providing excellent current-limiting overcurrent protection.





The CCP2 can also replace UL 489 circuit breakers as the main disconnecting means in an industrial control panel. UL 489 MCCBs have a range of interrupting ratings from 10 kA to 100 kA. Higher interrupting rating circuit breakers come with a cost-premium. Using a molded case circuit breaker as a main disconnect also tends to result in lower SCCR ratings for downstream components like power distribution blocks.

The CCP2 switches have a 200 kA SCCR and, by using current-limiting fuses, it provides excellent protection for downstream components. Most importantly, the CCP2 can do all this in a compact design that's comparable to a UL 489 MCCB's size, and much smaller than the traditional UL 98 fusible switch.

Table 3 shows the size and rating differences between the CCP2, a miniature circuit breaker and two different industrial circuit breakers.

Bold red text indicates device limitations.

Table 3 — CCP2 compared to miniature circuit breaker and fully rated industrial circuit breaker

	UL 98 CCP2 with Class CC or CF CUBEFuse fuses	UL 489 miniature circuit breaker	UL 489 low IR industrial circuit breaker	UL 489 high IR industrial circuit breaker
Visual reference				
Branch or feeder circuit disconnect	Yes	Yes	Yes	Yes
Branch or feeder circuit overcurrent protection	Yes	Yes	Yes	Yes
Voltage rating (AC)	600 V	240 V or 480/277*	600 V or less	600 V or less
Interrupting rating	200 kA or higher	10 kA or 14 kA	14 kA	Varies 14 kA -100 kA**
Current-limiting, listed and marked	Yes	Specific model dependant	No	Specific model dependant
Overcurrent protection method	Class CC fuse or CUBEFuse	Thermal magnetic trip	Thermal magnetic or electronic trip	Thermal magnetic or electronic trip
Cost	\$\$-\$\$\$	\$\$	\$\$\$	\$\$\$\$

* Limits application to solidly grounded Wye systems only, not permitted on ungrounded, resistance grounded or corner grounded systems.

**Interrupting rating also varies based upon the applied voltage.

Main disconnect applications

UL 508A typically requires industrial control panels to have a disconnecting means for each incoming supply circuit. Permissible devices include:

- UL 98 Fusible/non-fusible disconnect switches
- UL 489 Molded case switches
- UL 489 Insulated case circuit breakers
- UL 977 Bolted pressure switches

Most industrial control panels employ UL 98 or UL 489 devices as a main disconnect. The CCP2 is a UL 98 fused disconnect that features through-the door and through-the-side operation in a unique space-saving design that's ideal for main disconnect applications. CCP2s provide a 200 kA SCCR at 600 Vac and utilizes current-limiting fuses which can help increase component SCCR.

Both the Class CC and CF CUBEFuse CCP2s, up to 100 A are available with a rotary mechanism which is factory configured into the switch and requires no field-assembly or modification. The 200 and 400 A CCP2s utilize the front or side rotary mechanism accessories for rotary operation. This compact design results in a footprint that is up to 69% smaller than other fusible disconnect solutions.

The CCP2 offers a variety of selector, pistol and flange handle operators. NFPA 79 compliant handles are also available for front rotary CCP2 designs.

Another advantage of using the CCP2 as a main disconnecting means is the option to add multi-wire lug kits (come with finger-safe terminal shrouds) on the loadside. These lugs are rated 200 kA SCCR and accept a range of conductor combinations, including identical dual conductors in a single port. These multi-wire lugs can eliminate the need for a power distribution block, which often do not have high component SCCRs to achieve high equipment SCCRs. This creates additional space-savings on top of the compact switch design.

The current-limiting fuses installed in the CCP2 provide superior component protection and often result in a much higher SCCR for the power distribution block than if it were used with an upstream circuit breaker.

Sizing main disconnect fuses

Per UL 508A, the main overcurrent protective device (OCPD) amp rating for an industrial control panel cannot exceed either of the following:





- The largest branch circuit OCPD rating plus the full load currents of all other motors or other loads in the group
- The conductor ampacity or busbar amp rating on the OCPD's loadside

Main disconnect comparison

The CCP2 can replace traditional UL 98 disconnects and UL 489 circuit breakers in industrial control panels. It reduces panel space requirements, provides high SCCR and, when applied in a feeder circuit, may allow for increasing downstream branch circuit component SCCRs. Additionally, using CCP2s with multi-wire lugs can further reduce cost by eliminating the need for separate power distribution blocks.

Table 4 compares the CCP2 with multi-wire lugs to other more traditional disconnect solutions. These are the most common main disconnect options found in control panels. The power distribution block or multi-wire lug is essential in distributing power to multiple branch circuits and play a key role in the overall panel SCCR, space, cost and labor involved. The CCP2 with multi-wire lugs addresses all these factors at the most economical cost, the highest performance and smallest footprint.

Table 4: Main disconnect solution comparisons

	CCP2 with multi-wire lugs	Non-fused UL 98 disconnect with Class J power distribution fuse block	UL 98 Class J disconnect with UL Listed PDB	UL 489 industrial circuit breaker with multi-wire lugs	UL 489 industrial circuit breaker with UL Listed PDB
Visual reference					
SCCR	200 kA	200 kA	Up to 200 kA	Up to 100 kA*	Up to 65 kA**
Loadside lug options	Limited	Limited	Multiple	Limited	Multiple
Finger-safe	Yes	Yes †	No ††	Yes	No ††
Component cost	\$	\$\$	\$\$	\$—\$\$\$	\$\$—\$\$\$
Labor cost	\$	\$\$	\$\$	\$	\$\$

* SCCR in this example is the circuit breaker's interrupting rating (IR) which changes depending on the voltage at which it is applied.
**SCCR in this example is the lower of the circuit breaker's interrupting rating or the PDB SCCR.

† With installed cover.

††Finger-safe power distribution block available.

Application note







Compact Circuit Protector (CCP2)

Motor branch circuit solution comparison

The CCP2 with a magnetic starter is a cost-effective, compact straight voltage rated, high SCCR solution for motor circuits. Table 5 compares the CCP2 with a magnetic starter and other motor circuit solutions.

Bold red text indicates device limitations.

Table 5 — CCP2 applied as a combination motor controller (CMC) compared to alternate solutions

	UL 98 Class CC or CF CUBEFuse CCP2 with magnetic starter	UL 4248 Class CC or CF CUBEFuse holder with magnetic starter	UL 508 Self-Protected Starter (SPS) with magnetic contactor	UL 4248 Class CC or CF CUBEFuse holder and Manual Motor Protector (MMP) with magnetic contactor	UL 489 Recognized Motor Circuit Protector (MCP) with magnetic starter*	UL 489 circuit breaker with magnetic starter
Visual reference						
Branch circuit overcurrent protection	Yes	Yes	Yes†††	Yes	Yes*	Yes
Motor branch circuit disconnect	Yes	No	Yes	Yes**	Yes*	Yes
Voltage rating (AC)	600 V	600 V	480/277 V† or 600/347 V†	480 V or 600 V	600 V or less	600 V or less
CMC SCCR	100 kA	100 kA	5 kA to 65 kA††	5 kA to 65 kA††	5 kA to 100 kA***	5 kA to 100 kA***
High SCCR with multiple manufacturers	Yes	Yes	No	No	No	No
Cost	\$\$-\$\$\$	\$-\$\$	\$-\$\$	\$\$\$-\$\$\$\$	\$\$\$\$	\$\$\$\$\$

* Must be a listed MCP and starter combination, typically from same manufacturer.

** If on loadside of the final branch circuit overcurrent device and MMP is marked "suitable as motor disconnect."

*** Cost increases as MCCB interrupting rating increases, which is necessary for higher MCCB and starter combination SCCR.

† Limits application to solidly grounded Wye systems only, not permitted on ungrounded, resistance grounded or corner grounded systems.

†† SCCR is lower at higher voltage rating.

††† May require additional accessories such as line side terminals, to be used as a self-protected starter.

Motor branch circuit applications

In motor circuits, several important considerations must be analyzed to determine the best solution for the specific application. The first consideration is the ability to disconnect, isolate and lockout/tagout the motor for maintenance and enhanced safety.

Other important considerations to ensure design flexibility are:

- Increased interrupting ratings (IRs) and short-circuit current ratings (SCCR)
- Straight voltage rating versus slash voltage rating (e.g., 480 V vs. 480Y/277 V)
- Ratings with multiple manufacturers for a variety of components

Additionally, the CCP2 with installed fuses provides motor starters superior protection and Type 2 “No Damage” protection when properly sized. This greatly reduces downtime after short-circuit conditions.

Table 6 compares the three most common motor circuit alternatives that provide disconnect, isolation and lockout/tagout capabilities, and the affect on the other important considerations.

Table 6 — CCP2 and magnetic starter compared with other motor circuit protective devices

CCP2 with magnetic starter — equipment SCCR = 100 kA

The CCP2 with Class CC or Class CF CUBEFuse (with Class J electrical performance) and magnetic starter can achieve a high SCCR (100 kA) at a straight voltage rating (600 V) with multiple magnetic starter manufacturers in a smaller footprint.

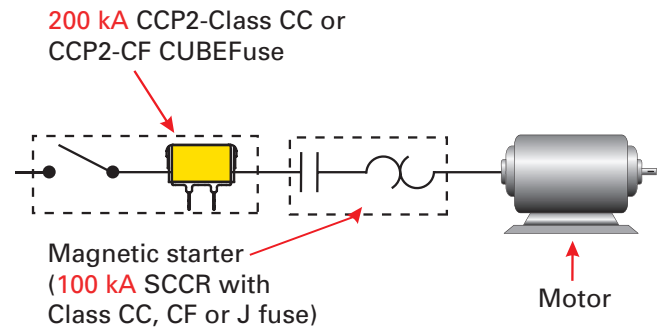

Self-protected starter with contactor — equipment SCCR = 5 kA to 65 kA

Self-protected starters generally have a relatively high SCCR, but are typically slash rated (480Y/277 V). Slash rated devices (480/277 V) cannot be used on 480 V (or higher) ungrounded, corner grounded or resistance grounded systems, which are becoming more common.

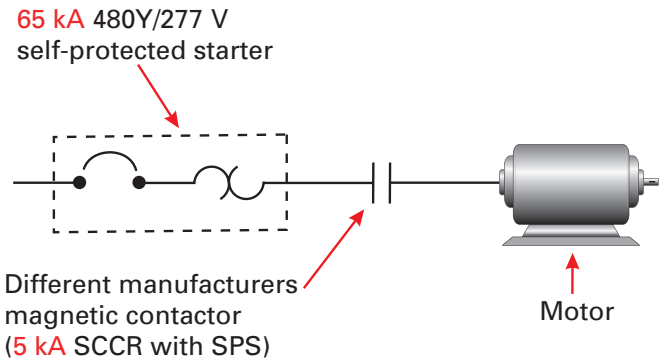

If using a magnetic contactor from a different manufacturer, the magnetic contactor will limit the equipment SCCR, since devices from different manufacturers have not typically been tested above the standard 5 kA short-circuit current rating. Similarly, some manufacturers have not tested magnetic contactors with self-protected starters at higher short-circuit current ratings.

Circuit breaker or Motor Circuit Protector with magnetic starter — equipment SCCR = 5 kA to 100 kA

Circuit breakers with magnetic starters can be used, but the SCCR ratings will vary based on the manufacturer’s combination rating and be typically limited to 5 kA if the magnetic starter and circuit breaker are from different manufacturers.

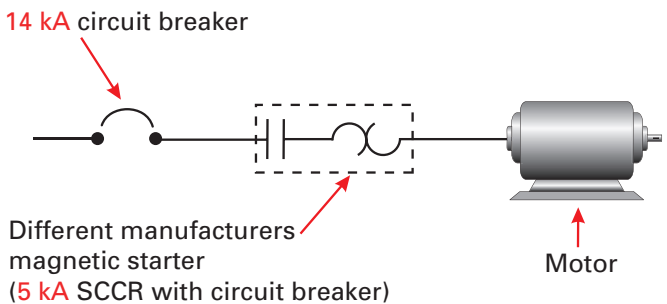

MCPs with magnetic starters can be used only if they’re part of a listed combination (typically must be from the same manufacturer).

Circuit breakers and MCPs can have a high SCCR if a high interrupting rating circuit breaker or MCP is selected for use with a magnetic starter from the same manufacturer. However, this can greatly increase the cost, and locks the user into only one manufacturer.

Application note





Compact Circuit Protector (CCP2)

Power electronics solution comparison

The CCP2 is a cost-effective, compact, straight voltage rated, high SCCR solution for protecting power electronic devices, such as variable frequency drives (VFDs). Table 7 compares the CCP2 with a drive to other motor circuit protection solutions.

Bold red text indicates device limitations.

Table 7 — CCP2 compared with alternative solutions for protecting drives

	UL 98 CCP2 Class CC or CF CUBEFuse	UL Class CC or CF CUBEFuse holder	UL 508 Self-Protected Starter (SPS)	UL 489 Recognized Motor Circuit Protector (MCP)*	UL 489 circuit breaker
Visual reference					
Branch circuit overcurrent protection	Yes	Yes	Yes†††	Yes*	Yes
Motor branch circuit disconnect	Yes	No	Yes	Yes*	Yes
Voltage rating (AC)	600 V	600 V	480/277 V**	600 V or less	600 V or less
SCCR with drive	100 kA***	100 kA***	5 kA to 65 kA†	5 kA to 65 kA††	5 kA to 65 kA†
High SCCR with multiple manufacturers	Yes	Yes	No	No	No
Cost	\$\$-\$\$\$	\$\$-\$\$	\$\$	\$\$\$\$	\$\$\$\$

* Must be part of a listed combination.

** Limits application to solidly grounded Wye systems only, not permitted on ungrounded, resistance grounded or corner grounded systems.

*** Verify SCCR rating with drive manufacturer. Some drive manufacturers may require specific Class J (DFJ) or high speed/semiconductor fuses.

† 65 kA SCCR may be available if the drive is marked for use with a specific SPS or circuit breaker and tested above the standard short-circuit current rating.

†† MCP must be marked and listed for use with the drive and included in the same overall assembly.

††† May require additional accessories, like lineside terminals, to be used as a self-protected starter.

Power electronics applications

Table 8 compares the three most common power electronics OCPD options and the impact on SCCR and other important considerations.

Note: To comply with UL 61800-5-1 requirements where high fault SCCR is needed, some VFDs require protection by only Class CC, CF,

J or T fuses. The CCP2 with installed fuses can provide disconnecting means and isolation for the VFD when replacement is needed after an internal failure of the drive.

Table 8 — CCP2 and drive compared with other overcurrent protective devices and drives

CCP2 with drive — equipment SCCR = 100 kA

The CCP2 with Class CC or Class CF CUBEFuse in combination with a VFD can achieve a high 100 kA SCCR at a straight voltage rating (600 V) in a smaller footprint. Consult Bussmann for drives with high SCCR ratings.

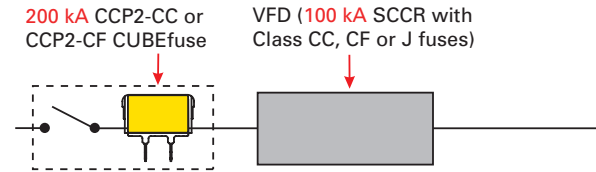

Self-protected starter with drive — equipment SCCR = 5 kA to 65 kA

If the manufacturer has not tested the drive with self-protected starters and contactors, the SCCR is typically 5 kA.

If the manufacturer also offers self-protected starters, it may be possible to use these component combinations to increase to the typical 65 kA SCCR. However, while the SCCR may be increased, the voltage rating is often slash rated (480Y/277 V) which limits the application to only solidly grounded Wye systems (480/277 V or less) as well as locking the user into one manufacturer.

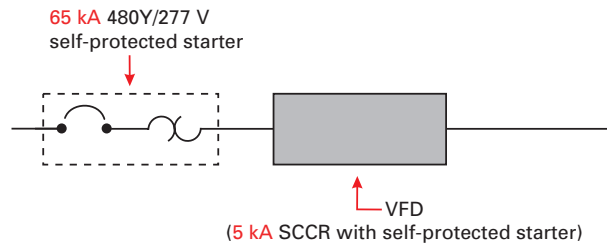

Circuit breaker or Motor Circuit Protector with drive — equipment SCCR = 5 kA

If circuit breakers are used, the VFD SCCR may be limited to 5 kA.

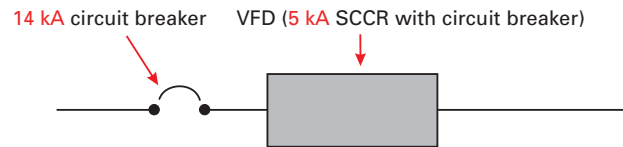

Resistive heating and lighting circuit applications

Branch-circuit OCPDs are required for protecting resistive heating and lighting circuits. Circuit breakers or fusible switches used for this purpose typically provide overload protection as well as short-circuit protection for the contactor, wiring and the load. However, two key factors must be considered when applying these devices:

- The short-circuit protection level provided to the components
 - The combination's assembly SCCR*
- * Low interrupting ratings or low component SCCRs will limit the assembly's overall SCCR.

The CCP2 is a cost-effective solution that does not limit the SCCR due to the fuse's interrupting rating and can be used to achieve a higher SCCR for the components, such as a magnetic contactor. In addition, the Class CF CUBEFuse and Class CC Low-Peak current-limitation offers the highest protection level for the contactor. In many cases, the contactor could be put back into service without any additional downtime.

The following two examples are different methods for protecting heating or lighting loads.

Enclosure 1 contains a 20 A molded case circuit breaker protecting a magnetic contactor. The contactor is rated 5 kA SCCR and the circuit breaker has a 14 kA interrupting rating. Per UL 508A this control panel would have a 5 kA assembly SCCR. See the contactor's label in Figure A for more detail.



Figure A

The schematic for Circuit 1 shows the schematic for the Enclosure 1. The schematic in Circuit 2 is for Enclosure 2 and uses the same contactor, but has a CCP2-CF and 20 A CUBEFuses for protection. The CCP2-CF has a 200 kA SCCR, the TCF Class CF CUBEFuse has a 300 kA interrupting rating and the contactor has a 100 kA SCCR when protected by a max 20 A Class J fuse. The overall assembly SCCR in this case is 100 kA. Note that UL 508A allows substituting a Class CF fuse for Class J as they have the same UL I_{peak} and I^2t let-through limits. The CCP2-CC with 20 A LP-CC fuses could also be used in this situation.

Table 9 — CCP2 compared to circuit breakers for protecting heating/lighting circuits

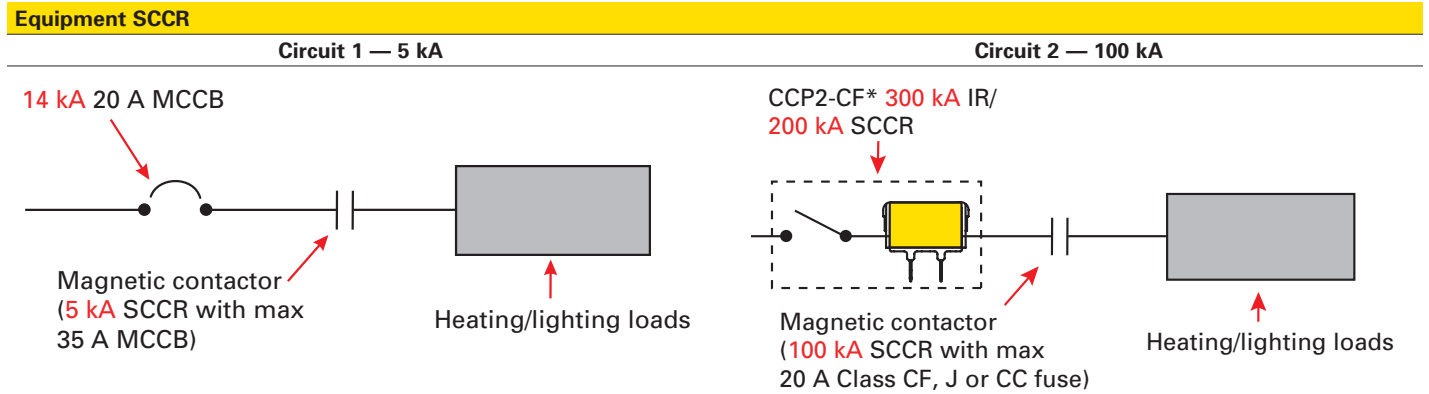

* The PLC fuse monitors for CCP2 up to 100 A can be used to open the contactor if a fuse opens and prevent single phasing the load.



Enclosure 1



Enclosure 2

While both methods provide the required branch-circuit protection, they have two very different outcomes. The fusible solution provides a higher interrupting rating, a higher combination SCCR for the contactor, and superior component protection of the conductor. By leveraging the many advantages of the CCP2 and 20 A Class CF CUBEFuses, the resulting 100 kA assembly SCCR provides flexibility for installation in most any electrical system without fear of misapplication.

Due to cost considerations, circuit breakers with low interrupting ratings and slash voltage ratings are often used in these applications. Although different circuit breakers with straight voltage ratings and higher interrupting ratings can be used (resulting in increased cost), other circuit components, such as magnetic contactors, may have low short-circuit current ratings when protected by circuit breakers. Low interrupting ratings or low component SCCR will limit the equipment SCCR and result in limited use and potential misapplication.

Misapplications can be devastating. Enclosure 1 was subjected to a 25 kA fault at 480 Vac in the Paul P Gubany Center for High Power Testing. In this case, the enclosure was torn apart by the extreme mechanical forces and vaporization of metal conductive parts resulting in shrapnel, shock and fire hazards. Photos during and after the test are shown in Figure B and C. If this were to happen in the field, the entire assembly would need replacing, causing downtime and additional cost and may have ignited flammable material in the proximity.

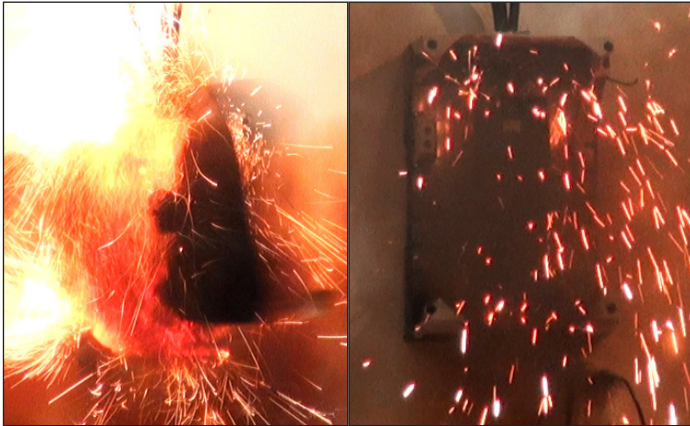

Figure B. During misapplication test (enclosure 1)



Figure C. After the breaker test

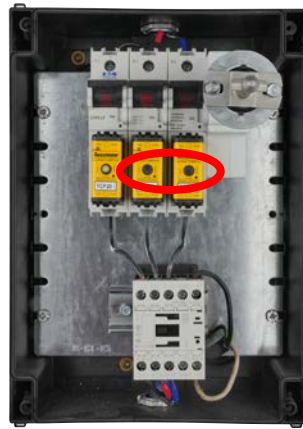
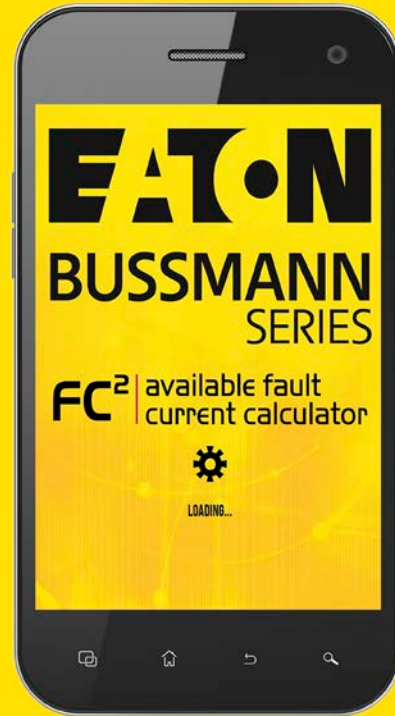

Figure D. After the fuse test

For comparison, the same test was performed on Enclosure 2 with eventful results (see Figure D) — no shrapnel, shock, or fire hazards were present. In addition, the contactor did not sustain any additional damage and could be put back into service without any problems. The photo in Figure D shows two fuses opened in this line-to-line fault (see indicator window in fuse center). Using the CCP2 is an easy means to comply with the NEC and provides a safe, worry-free installation in resistive heating and lighting applications.

Calculate available fault current anytime, anywhere



Eaton's most popular app, the Bussmann series FC² Available Fault Current Calculator, puts available fault current calculations in the palm of your hand.

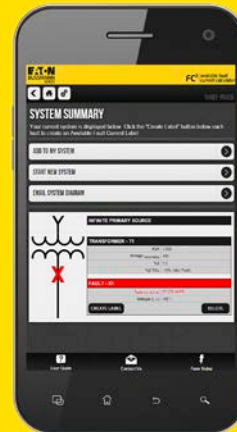

FC² calculates single- and three-phase system fault current levels and makes point-to-point calculations easy. It also generates NEC[®] compliant labels, one-line diagrams, and documents the calculations. Plus, it features fuse sizing guide for main, feeder and branch circuits.

FC² is free and available for all Apple iPhones, iPads, and Android™ mobile devices. It has English, Spanish and French modes to address local language and equipment marking requirements.

Visit Eaton.com/bussmannseries to learn more or use the web-based version.

Control circuit applications

When control circuit transformers or power supplies are tapped from the feeder circuit, UL 508A requires protecting the control circuit by a branch circuit OCPD. When tapped from the branch circuit, only supplemental overcurrent protection is required. However, in both cases, the equipment SCCR cannot be higher than the control circuit OCPD's interrupting rating.

The CCP2 can be used in these applications to provide cost-effective overcurrent protection, high interrupting rating and increased equipment SCCR. Where supplemental protectors and standard circuit breakers are used, the voltage rating and interrupting rating limits the equipment's application unless more expensive, higher rated circuit breakers are used. Table 10 compares the CCP2 with supplemental protectors and circuit breakers for these applications.

Often a CCP2 may be preferable to a fuse and fuse block solution due to its ability to provide a disconnecting means for the downstream control power transformer (CPT) or power supply. This would alleviate any design requirement to put a separate disconnecting means in series with the fuse/fuse block, therefore reducing footprint, component count and labor while raising circuit SCCR.

Sometimes the CPT or power supply is fed separately from an upstream source to allow for the low-voltage control panel and the power control panel to operate even when the other is offline. When this design is applied, customer preference for a high SCCR branch disconnecting means, like the CCP2, is very likely.

Table 10 — CCP2 compared to circuit breakers in protection of control circuits

Control circuit tapped from branch circuit	
Equipment SCCR = 200 kA	Equipment SCCR = 5 kA
<p>Motor branch OCPD</p> <p>Supplemental OCPD permitted, but may lower SCCR. For higher SCCR, utilize 200 kA CCP2-Class CC .</p> <p>Power supply or control transformer</p> <p>Motor</p>	<p>Motor branch OCPD</p> <p>Supplemental OCPD permitted, 5 kA supplementary protector</p> <p>Power supply or control transformer</p> <p>Motor</p>
Control circuit tapped from feeder circuit	
Equipment SCCR = 200 kA	Equipment SCCR = 14 kA - 100 kA*
<p>Feeder circuit OCPD</p> <p>Branch circuit OCPD</p> <p>Branch circuit OCPD required, 200 kA CCP2-Class CC or CCP2-CF CUBEFuse</p> <p>Power supply or control transformer</p> <p>Motor</p>	<p>Feeder circuit OCPD</p> <p>Branch circuit OCPD</p> <p>Branch circuit OCPD required, 14 kA circuit breaker</p> <p>Power supply or control transformer</p> <p>Motor</p>

* Cost increases with higher interrupting rating.

Note: Power supplies must be listed for use with the overcurrent device selected. A manual motor protector cannot be used for overcurrent protection of power supplies tapped from the feeder circuit or the branch circuit.

Applying CCP2 accessories

This section covers applying these CCP2 accessories:

- PLC fuse monitor
- Auxiliary contacts
- Multi-wire lugs and shrouds
- Rotary handle options

PLC fuse monitor

The CCP2 PLC fuse monitor will read an open fuse's condition and provide an input signal to a 24 Vdc PLC input card. The catalog numbers are CCP2-PLC-IND for Class CC and Class CF CUBEFuse up to 60 A, and CCP2-PLC-100 for the 100 A CCP2.

The input provided to the PLC is a +24 Vdc / 10mA signal that is an active high input. This active high signal indicates that a fuse within the switch has opened. If the switch is multi-pole, this signal is simply an alert that one or more fuses have opened. The local indication light built into the CCP2 switch will indicate specifically which fuse or fuses are open.



CCP2R-3-60CF

Wiring

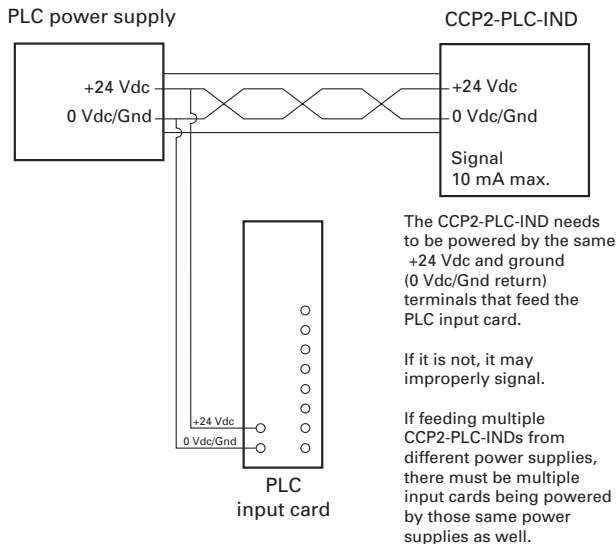

The PLC fuse monitor meets a number of IEC emissions and noise immunity standards related to electromagnetic compatibility. It's advised that the installer utilize twisted/shielded pair when wiring the module as shown above. It's also necessary that the same +24 Vdc power supply is used to power both the PLC input module as well as the PLC fuse monitor.

Installation

The PLC fuse monitor mounts ONLY on the CCP2's left side and mechanically interlocks with the CCP2 switch handle with provided hardware. The CCP2-PLC-IND and CCP2-PLC-100 CANNOT be mounted on the left front/left side rotary operated versions or if a multi-wire lug kit is installed.

The PLC fuse monitor signal line is designed to provide a digital input to a PLC I/O module. In this case, a Programmable Logic Control program must be written to properly interpret the input signal to the PLC. The PLC program should check for consecutive high signals before taking action on a critical process.

The interlocking handle of this unit functions to reset a high signal once the switch handle to which it is connected is set to the OFF position (OFF position is required when replacing open fuses. Opening the fuse access door on the CCP2-CC/M will trip the switch to the OFF position. The CCP2-CF must be manually switched to the OFF position before a CUBEFuse can be removed or installed). After replacing a fuse and the switch is turned back to the ON position, the PLC signal from the PLC monitor should be low, indicating the fuse is good.

Auxiliary contact

The CCP2 auxiliary contact detects the switch handle's position and provides 1 NO and 1 NC contact for signaling to a PLC input or other device. The part number is CCP2-AUX for Class CC fuses and Class CF CUBEFuse up to 60 A or CCP2-AUX-100 for the 100 A CCP2-CF and CCP2-AUX-S for the 200 and 400 A switches.

The contact is rated for use up to 240 Vac and 5 amps. The normally open (NO) contact acts in the same position as the switch, so that when the switch is closed (power is ON) the auxiliary contact is also closed. The normally closed (NC) contact acts in the opposite manner — so that when the switch is closed, this contact is open.

The auxiliary contact allows for remote electrical system diagnostics or system annunciation based on the switch's status (ON or OFF) in comparison to the rest of the electrical system's status.



CCP2RL-3-60CF



CCP2-3-400CF

Installation

The auxiliary contact mounts only on the 30 to 100 A CCP2's right side and mechanically interlocks with the CCP2 switch handle with provided hardware. The CCP2-AUX and CCP2-AUX-100 CANNOT be mounted on the right front/right side rotary operated CCP2 versions.

The CCP2-AUX-S mounts on either the right or left side of the 200 and 400 A switches, depending on the desired application.

Multi-wire lugs and shrouds

The multi-wire lug kits permit expanding each CCP2 box lug terminal into a 3-port (30 and 60 A switches) or 6-port (100 A switches) terminal for power distribution applications.



3-port for CCP2 up to 60 A and 6-port for 100 A CCP2



6-port for 200 and 400 A CCP2

Each multi-wire lug kit comes with three lugs and shrouds. Shrouds provide finger-safe protection when properly installed.



Installation

3- and 6-port multi-wire lugs may be installed on either the loadside or lineside of the box lug terminal (up to 100 A) and the loadside terminals of the 200 and 400 A switches to meet various application needs. The terminal shrouds are designed to slide into dovetails on the CCP2. Ports on the multi-wire lug accept any conductor combination listed, e.g., one port may have dual 14 AWG wires and the other two ports single 10 AWG wires.

Rotary handle options

Selector and pistol handles

Selector and pistol handles are available for any 2- and 3-pole CCP2 rotary operated switch. Both are available in black/gray and red/yellow colors in clockwise and counterclockwise operating versions. Clockwise and counterclockwise operation is dependent upon the CCP2 rotary switch configuration. Installation requires an 8 mm shaft (30-100 A switches) or 12 mm (200 and 400 A switches) — ordered separately.



- Red/yellow
- Black/gray

Each handle is rated Type 1, 4X and 12, and accepts up to three (3) 1/4" locks for lockout/tagout in the OFF position. They can also be field configured for lock-on and defeatable.

In application, only the clockwise operating handles in combination with front rotary switches provide a door interlock means to ensure the enclosure door remains shut during lockout/tagout or lock-on. Operating handles when mounted on the enclosure's left or right side do NOT provide a door interlock means.

In addition to the traditional, "through-the-door" type disconnecting means, you may alternately select one of the available left or right side-operated switches. Doing so will necessitate the use of the appropriate left or right side handle.



Side rotary operation

Front rotary operation

Does not provide door interlock

Flange handles



The CCP2-FLR1_ and CCP2-FLR2_ flange rod, and CCP2-FLC1_ and CCP2-FLC2_ flange cable operating mechanisms allow for the CCP2 disconnect switches to be actuated via a side mounted flange handle on a control panel.

The standard handle is for NEMA 1, 3R, and 12 enclosures while the chrome handle version is for NEMA 4X enclosures.

The flange handles preclude using the optional PLC fuse monitor and auxiliary contacts on switches up to 100 A.

NFPA 79 handle

The NFPA 79 compliant handles serve two main purposes:

- To operate the disconnect switch independent of the door position with a deliberate action
- Provide a lockout means independent of the door position



This type of handle mounts directly to the switch's shaft and allows the shaft used by the external handle to pass through it. If the panel door is open, a qualified person may operate the switch OFF or ON as well as lockout in the OFF position.

Common misapplications in industrial control panels

The motor branch circuit and the requirements for each functional component are very unique and often misunderstood. Each component, including the OCPD, and the disconnecting means must be properly applied for safe and reliable protection. This section will outline several common component misapplications and provide solutions using the CCP2.

1. Motor switch or manual motor controller as a main feeder or branch circuit disconnect



Manual motor controllers, Listed to UL 508, are used for the ON/OFF or manual “controller” function to meet NEC requirements in Article 430 Part VII. They have creepage and clearance distances less than those required by UL 98 for the main, feeder or branch circuit disconnects. In some cases, these devices may be used as the “at the motor” disconnect if marked “Suitable as motor disconnect”.

Users may mistake these small, low cost manual motor controllers as disconnect switches that must meet the requirements for branch and feeder disconnects per NEC 430.109. UL 98 disconnect switches have more robust testing requirements and can be applied on mains, feeders and branch circuits of service entrance equipment, panelboards, switchboards, motor control panels, industrial machinery and control panels. Look for the marking “Listed Misc. Sw” or “Open Type Switch” for listed disconnect switches. Don’t let the manual motor controller’s low cost and small size lead to misapplication. Welding of the contacts and other damage could occur if the product is used in such applications.

The CCP2 with CUBEFuse offers the ideal solution for motor branch-circuit and feeder disconnecting means. It’s a UL 98 disconnect switch with a 200 kA SCCR. The UL 98 switch ratings allow it to be used in most any disconnect application while saving significant space in the enclosure. In addition, the horsepower ratings allow it to be used as the “at the motor” disconnect.

2. Manual motor starters or manual motor protectors as branch-circuit short-circuit protection

Manual motor starters (or manual motor protectors), sometimes called MMPs, are permitted to provide motor overload protection as required per NEC 430.32 and provide motor control. For proper application they require a motor branch-circuit OCPD, and a motor branch-circuit and controller disconnect on the lineside.



These devices are often mistaken for the required branch-circuit protection required in motor circuit applications due to their low cost and small size. However, they are not listed nor permitted to provide branch circuit protection as the creepage and clearance distances are typically not as great as required in UL 489, and therefore cannot be tested and listed as a circuit breaker.

The solution is to use the UL 98 CCP2 switch with CUBEFuses or Class CC fuses to provide the required branch-circuit short-circuit protection. This is a cost effective, code compliant solution for branch-circuit protection.

3. Fuse holders used as a disconnecting means



UL 4248 fuse holders may be used in group switching applications with a motor branch-circuit disconnect and properly sized branch-circuit fuses on the lineside. These devices will be marked “Listed Fuse Holder” with a UL symbol.

To save costs, fuse holders, especially the pullout style, are misapplied and used in lieu of the required disconnect. This can lead to an unsafe condition as they are not indented for load break.

They cannot be used alone as a motor branch-circuit and controller disconnect, or as an “at-the-motor” disconnect to meet NEC 430.109, nor can they be used alone as a motor controller (ON/OFF function) to meet NEC Article 430, Part VII.

The solution is to use the CCP2 with CUBEFuse or Class CC fuses to provide the safe circuit disconnecting means.

4. Supplemental protectors (mini-breakers) or supplemental fuses used as branch-circuit protection

Supplemental protectors recognized to UL 1077, commonly called mini-breakers, and supplemental fuses offer limited protection and performance, and must rely on the upstream branch-circuit OCPD. In industrial control panel applications, these supplemental protectors are typically limited to use on the control circuit. Limited interrupting ratings, voltage ratings and function restrict their use.



UL 1077

Supplemental protectors (mini circuit breakers)

While supplemental OCPDs cannot be used in place of branch-circuit OCPDs, a branch-circuit rated OCPD can be used in lieu of a supplemental OCPD. Understanding the differences between these devices is important to ensure their proper application. Not using a branch-circuit OCPD where required could result in potentially serious electrical safety hazards to people or damage to property. In addition, NEC violations could be tagged by the authority having jurisdiction (AHJ), resulting in project delays and unplanned delays and costs.



UL 248-14

Supplemental fuses

The CCP2 with CUBEFuses or Class CC fuses is a simple and easy replacement for supplemental devices and can always replace them anywhere in the circuit. Using the CCP2 with UL branch-circuit fuses in mains, feeders, branch-circuits and control circuits can be safely made without fear of misapplication.

5. Improper or insufficient OCPD interrupting ratings

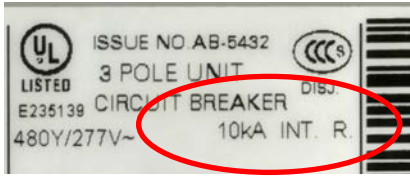

The OCPD interrupting rating is one of the most important safety-related ratings for both equipment and personnel to ensure it can safely interrupt destructive fault current energy.

If the fault current exceeds a level beyond the OCPD's capability, it may rupture causing damage and pose a serious safety risk. The rating that defines OCPD's capacity to maintain its integrity when reacting to fault currents is its interrupting rating. It's important when applying a fuse or circuit breaker to use one that can safely interrupt the highest potential fault currents. NEC 110.9 requires equipment intended to interrupt current at fault levels to have an interrupting rating sufficient for the available fault current at the point of application.

Too often OCPDs with very low interrupting ratings, such as 10 kA or 14 kA, are used due to their attractive low cost. However, this limits their use and application in the equipment or control panel in which they are applied. In addition, misapplication is easy unless the installer is very careful to understand the available fault current at the point of application. The low interrupting ratings are also a limiting factor in the overall assembly SCCR. The panel or equipment SCCR can never be higher than the lowest OCPD interrupting rating.

The following images depict a test conducted on a 480 V circuit breaker with a 14 kA interrupting rating and a test circuit capable of delivering 50 kA fault current at 480 V. These dramatic results can be viewed by scanning the QR code. This is a serious misapplication and safety hazard that must not be overlooked.

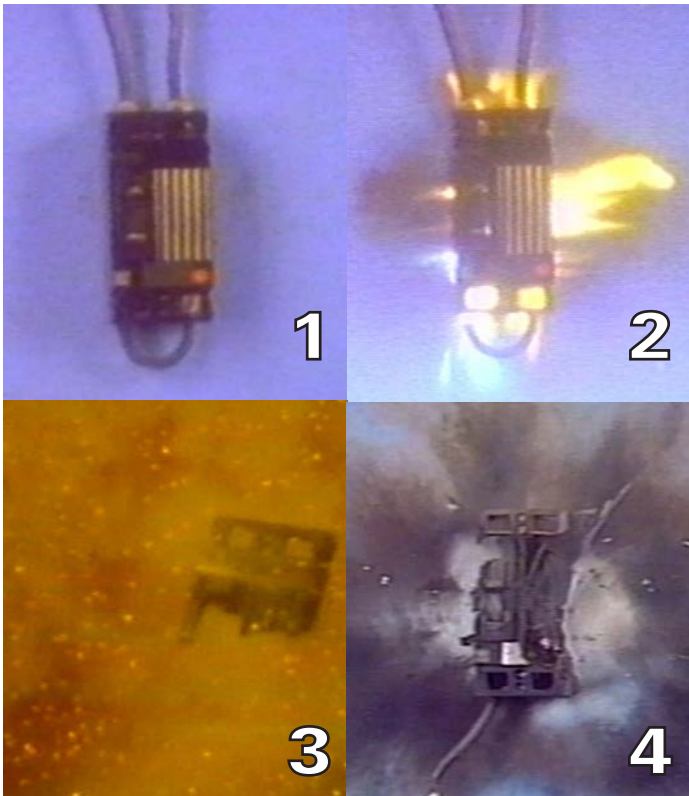

The CUBEFuse, used in the CCP2 with a 200 kA SCCR, has a 300 kA interrupting rating up to 100 A and 200 kA from 110 to 400 A and can be used in any system without fear of misapplication. In addition, the fuse will not be the limiting factor in determining the panel SCCR. The CCP2 with CUBEFuse has been found to be the most economical and smallest solution for meeting the needs of safe fault current interruption.

6. Motor circuit protectors (MCPs) or instantaneous trip only circuit breakers as branch-circuit protection in other than Type D motor controller combination

Motor circuit protectors (MCPs) used in combination with a motor controller and motor overload device provide short-circuit protection only in motor circuits. These devices do not carry a standalone interrupting rating. They have a combination SCCR when used with the listed devices as part of a Type D motor controller. They cannot be used as a standalone branch-circuit device, such as a listed UL 489 molded case circuit breaker.



MCPs are easy to misapply due to their lower price and appearance, as they look very similar to a UL circuit breaker. However, using MCPs beyond their intended short-circuit protection could be catastrophic. They are not tested to interrupt the full range of available fault currents as a branch-circuit OCPD.

The CCP2 with CUBEFuses or Class CC fuses is a solution to provide the required branch-circuit protection in a very small, compact size. The UL fuses provide high interrupting ratings and current-limitation for the highest protection level for motor starters, contactors and other components. In addition, the Bussmann series CUBEFuse or LP-CC fuses can offer superior Type 2 "No Damage" protection for motor starters over the MCP.

7. UL Recognized terminal blocks in feeder circuits without the required feeder spacings per UL 508A



Power distribution blocks (PDBs), are used to distribute power to multiple branch circuits or control circuits. For proper application in industrial control panel feeder circuits, they require minimum spacings through air and over surface.

Most power distribution blocks are actually terminal blocks and are recognized to UL's terminal block standard, UL 1059. Many of these terminal blocks do not meet the required feeder spacings as seen in power distribution blocks listed to UL 1953.

It's a misapplication to use UL 1059 Recognized terminal blocks in feeder circuits. This violates UL 508A and may be a safety hazard. Listed PDBs have adequate spacing for feeder circuit applications. In addition, UL Recognized terminal blocks have very low short-circuit current ratings.

The CCP2 with the available multi-wire lug kit incorporates the power distribution block's function into the disconnect switch. This not only ensures compliance with UL 508A feeder spacing requirements, but also eliminates the space and labor associated with wiring up the additional component. Finally, this solution provides a 200 kA SCCR and will not be a limiting factor in the panel's overall SCCR.

8. A slash rated device in any system other than solidly grounded Wye



The OCPD's voltage rating must be considered when applying both fuses and circuit breakers. Proper application requires the OCPD's voltage rating be equal to or greater than the system voltage. When an OCPD is applied beyond its voltage rating, there may not be any initial indications that anything is wrong, but when it attempts to interrupt an overcurrent, adverse consequences can result and it may self-destruct in an unsafe manner.

There are two OCPD voltage rating types:

- Straight voltage rated
- Slash voltage rated

A straight voltage rated OCPD can be installed in any electrical system regardless of the grounding system.

Slash voltage rated OCPDs, such as 480Y/277 V, have limitations imposed upon them that straight rated voltage OCPDs do not. Multiple-pole, mechanical OCPDs with a slash voltage rating, such as circuit breakers, self-protected starters and manual motor controllers, are limited in their application and require extra evaluation for use. These devices can only be applied where the system's:

- Line-to-line voltage does not exceed the higher voltage number
- Line-to-ground system voltage does not exceed the lower of the two numbers.

Misapplication can cause dire consequences, and lead to unforeseen downtime and other safety concerns.

The Class CF CUBEFuse or Class CC fuses in conjunction with the CCP2 are straight voltage rated and their proper application is straightforward (i.e., 600 V, 480 V, 240 V). These OCPDs have been evaluated for proper performance with full phase-to-phase voltage used during testing, listing and marking. Utilizing the CCP2 and UL Listed fuses will help prevent any possibility for misapplication. In addition, when any slash rated devices are used in a panel or assembly, the equipment's voltage rating must reflect this limitation that restricts the equipment's installation in only solidly-grounded Wye systems.

Determining equipment SCCR

The NEC does not require industrial control panels to be listed, but it does require industrial control panels to be marked with the SCCR. UL 508A Supplement SB is referenced as an approved method to determine the equipment or assembly SCCR. To comply with the Code, this rating must be greater than the available fault current at the point of installation. In most cases, the "default" SCCR value often given of 5 kA is not sufficient. The following four steps describe the general process used to determine the equipment SCCR based on the UL 508 SB method.

1. Determine short-circuit current ratings for power circuit components

Power circuit components supply external loads such as motors, heating, lighting, appliances or maintenance receptacles as well as the branch circuit protection for control circuits. Most power circuit components can be tested to a much higher SCCR than the standard test when applied with a specific fuse or circuit breaker. This is called the high-fault rating.

2. Verify whether a current-limiting device is upstream (in the feeder circuit) of the branch circuit overcurrent protective device and components.

Current-limiting devices (fuses and circuit breakers) in the feeder circuit can limit the current to downstream branch circuit components thereby raising the branch component's SCCR but not the branch circuit overcurrent protective device interrupting rating. In addition, transformers also limit current to downstream branch circuit devices. If the let-through of transformer is less than the rating of the branch circuit overcurrent protective device and components, the interrupting rating of the feeder circuit overcurrent protective device on the line side of the transformer can be used in lieu of the load side branch circuit overcurrent protective device and component ratings if higher.

3. Determine the interrupting ratings for all the fuses and circuit breakers in the feeder and branch circuits

Interrupting ratings of fuses and circuit breakers are a limiting factor in the overall panel SCCR. Choose devices such as current-limiting fuses with high interrupting ratings for the best protection and highest SCCR.

4. Find the lowest component SCCR or overcurrent protective device interrupting rating based on steps 1 through 3

This method can often be difficult to understand and apply. In most cases, a 5 kA or even 10 kA SCCR will not provide the proper short circuit rating and can lead to safety hazards if misapplied. Eaton's Bussmann division Field Application Engineers are experts in applying UL 508A Supplement SB and achieving high SCCR. Contact your local Bussmann representative to get in touch with an expert engineer.

Other applications using CCP2

The CCP2 is an ideal solution in many other applications besides industrial control panels and machinery. The following highlight some applications and equipment where the CCP2 provides advantages over traditional solutions.

Data centers

The CCP2 is used in data center applications to improve electrical safety, and increase reliability and flexibility. The CCP2 and CUBEFuse mounted in Busway switches allow the fuse to be serviced without removing the deadfront. This provides a safer installation and simplifies fuse replacement. In addition, the CUBEFuse has high interrupting ratings up to 300 kA to provide for a more flexible and reliable installation that will help meet applicable NEC requirements. Remote power panels (RPPs) with CUBEFuses and CCP2 help to easily meet selective coordination requirements in data centers to increase uptime.



Busway switch with CCP2



RPP with CCP2B

UPS — critical applications

An important design consideration for making power systems reliable is to maintain power to critical system loads as part of the uninterruptible power supply (UPS). The CCP2 is used in the Quik-Spec Coordination Panelboard with CUBEFuses to protect the UPS loadside in petrochemical and other critical process industries. The CUBEFuse and CCP2 help to prevent damage from dropout due to a fault on one branch circuit. In addition, the CUBEFuses are easily selectively coordinated with upstream Low-Peak fuses maintaining system continuity and reliability.

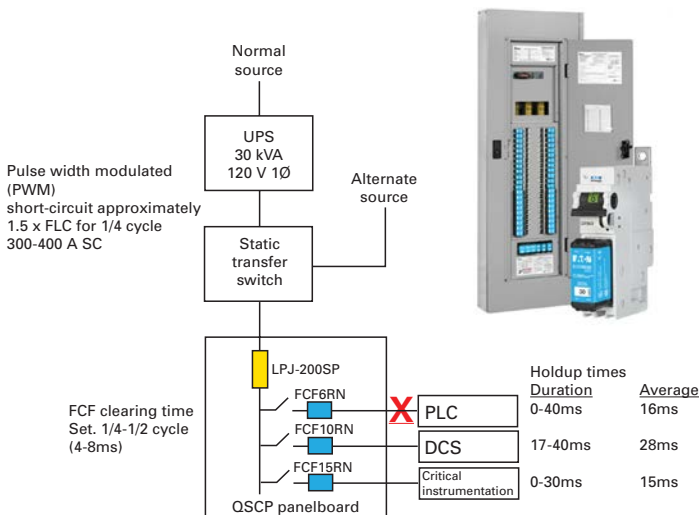

Other critical electrical systems

Reliability is a key component in critical electrical systems where unnecessary power loss could lead to life safety or national security concerns. This is the case for emergency systems, critical operation power systems, critical operations data systems and legally required standby systems. The National Electrical Code requires selective coordination in these systems and the CCP2B with the CUBEFuse installed in the Quik-Spec Coordination Panelboard address this requirement. The fusible panel makes it easy to selectively coordinate while providing the highest level of protection for these critical systems.



QSCP with CCP2B

Switchboards, switchgear, motor control centers

The CCP2 offers a compact, touch-safe disconnecting means for control circuits, metering and power supplies in switchboards, switchgear and motor control centers. Often, fuses are used in these circuits without a disconnecting means when not required by Code. However, if tapped from a 208 or 480 V bus, a disconnect and branch circuit fuses are required. In both cases, the CCP2 provides the smallest fusible switch with a high level of protection in these tight spaces for all types of electrical assemblies.

Custom panelboards and switchboards

The CCP2 can be incorporated into various custom panel and switchboard applications. For convenience, a chassis with the bolt-in mounted CCP2 is available. This allows for easy insertion into custom applications to split multiple loads or for multiple branch circuits. One common application is found in utility substations. The fusible panelboard feeds the 125 Vdc battery bank providing isolation and selective coordination with upstream feeder circuits. The fuse interlock provides an additional level of safety in all applications.



QSCP chassis with CCP2B

Fuse selection

There are many considerations when selecting the proper fuse for an application, including, but not limited to:

- Voltage rating
- Amp rating
- Interrupting rating
- Component protection
- Selective coordination
- Performance characteristics (dual-element time delay, time-delay, non-time delay, or high speed)
- Degree of current-limitation
- Physical size
- Mounting means (block, holder or switch)
- Electrical safety related work practices

In addition, it's important to comply with equipment nameplates marked with short-circuit current ratings that are dependent on a specific type overcurrent protective device amp rating.

This section provides condensed general guidelines for determining fuse amp ratings, primarily for the dual-element time-delay Class CF CUBEFuse and the Class CC LP-CC and FNQ-R fuses. In most applications the amp rating has to comply with the National Electrical Code and/or UL product standards. Many of the NEC and UL product standards provide maximum amp ratings. These guidelines may suggest lower amp ratings than these maximums.

There is more in-depth application information online in various publications including:

- SPD Selecting Protective Devices based on 2017 NEC (no. 1007)
- Data sheets
- Application notes

Loads without significant inrush current

For these loads, the circuit conductor ampacity typically has to be at least 100% of the non-continuous load current plus 125% of the continuous load current. Generally, the fuse amp rating is sized the same as the circuit conductor ampacity, with the exception that the next standard fuse amp rating is permitted in some cases.

Transformer protection

When a transformer is energized, the primary experiences an inrush current that's a function of its design. This inrush current may require sizing the primary fuses greater than 125 % of the transformer primary full load current. It's recommended to verify the transformer primary inrush current with the manufacturer and review the fuse's time-current curve characteristics. Control transformers often have very high inrush currents. Of the two fuse types, the time-delay Class CF CUBEFuse generally has better time-delay for transformer primary protection. If using Class CC fuses, the FNQ-R fuse is suggested for primary transformer protection due to its time-current characteristics, especially for FNQ-R fuses 7-1/2 amps and less.

Transformers are one component in an electrical circuit and OCPD selection must consider conductors and other equipment in the circuit requiring protection. In addition to complying with 450.3, other NEC requirements for protecting circuits with transformers must be considered, including 240.4, 240.21(C)(1), and 408.36(B).

Transformers 600 V nominal or less (NEC 450.3)

Protection type	Thermal overload protection	Transformer impedance	Rated current	Optimum protection*	NEC maximums	Fuse/volt recommendation
Primary only (Note: components on the secondary still need overcurrent protection)	—	—	Primary < 2 amps	125% or next size larger	300% or next size smaller (see NEC 430.72(C) for control circuit transformer maximum of 500%)	Up to 600 V • Class CF time-delay CUBEFuse (TCF) • Class CC FNQ-R
			Primary ≥ 2 amps but < 9 amps	125% or next size larger	167% or next size smaller	
			Primary ≥ 9 amps	125% or next size larger	125% or next size larger**	
Primary and secondary	Without	—	Secondary < 9 amps (see A)	Primary and secondary fuses at 125% of primary and secondary FLA or next size larger	% of primary FLA (or next FLA size smaller) A = 250% B = 250% C = 600% D = 600% E = 400% F = 400% % of secondary FLA A = 167% or next size smaller B = 125% or next size larger** C = 167% or next size smaller D = 125% or next size larger** E = 167% or next size smaller F = 125% or next size larger**	
			Secondary ≥ 9 amps (see B)			
	With	≤ 6%	Secondary < 9 amps (see C)			
			Secondary ≥ 9 amps (see D)			
		> 6% but < 10%	Secondary < 9 amps (see E)			
			Secondary ≥ 9 amps (see F)			

* When sizing the primary fuse for optimum protection, verify the inrush current with the transformer manufacturer and review fuse time-current characteristics.

**When 125% of FLA corresponds to a standard rating, the next larger size is not permitted.

Motor branch circuit protection

Across the line motor starting can create significant inrush currents. As a result, across the line motor starting typically has two forms of overcurrent protection for a motor branch circuit and motor:

- Overload protection, 430.32
- Branch circuit short-circuit protection, 430.52.

The following tables are suggested for motor branch circuit short-circuit protection using time-delay Class CF CUBEFuse or the Low-Peak Class CC fuses. See motor branch circuit protection fuse sizing notes for more information on fuse sizing.

LP-CC time-delay Class CC fuses

Voltage	Motor size (Hp)	Motor FLA (amps)	Min (amps)	NEC code max (amps)	Heavy start (amps)
115 Vac, 1-phase	1/6	4.4	9	15	15
	1/4	5.8	12	20	20
	1/3	7.2	15	25	25
	1/2	9.8	30	30	30
230 Vac, 1-phase	1/6	2.2	4.5	10	10
	1/4	2.9	6	10	10
	1/3	3.6	7	15	15
	1/2	4.9	10	15	15
	3/4	6.9	15	25	25
	1	8	25	25	30
200 Vac, 3-phase	1-1/2	10	30	30	30
	1/2	2.5	5	10	10
	3/4	3.7	7.5	15	15
	1	4.8	10	15	15
	1-1/2	6.9	15	25	25
208 Vac, 3-phase	2	7.8	25	25	30
	1/2	2.4	5	10	10
	3/4	3.5	7	15	15
	1	4.6	10	15	15
230 Vac, 3-phase	1-1/2	6.6	15	20	25
	2	7.5	15	25	30
	1/2	2.2	4.5	10	10
	3/4	3.2	7	10	12
460 Vac, 3-phase	1	4.2	9	15	15
	1-1/2	6	12	20	20
	2	6.8	15	25	25
	3	9.6	30	30	30
	1/2	1.1	2.25	6	6
	3/4	1.6	3.2	6	6.25
575 Vac, 3-phase	1	2.1	4.5	10	10
	1-1/2	3	6	10	12
	2	3.4	7	15	15
	3	4.8	10	15	15
	5	7.6	25	25	30
200 Vac, 3-phase	1/2	0.9	1.8	3	3.5
	3/4	1.3	2.8	6	6
	1	1.7	3.5	6	6.25
	1-1/2	2.4	5	10	10
	2	2.7	5.6	10	10
200 Vac, 3-phase	3	3.9	8	15	15
	5	6.1	15	20	20
	7-1/2	9	30	30	30

Note: NEMA motors only (no IEC or design B energy efficient). Minimum size if no more than 1 start/hour. NEC code max if low to moderate reverse/jog/plug applications.

Heavy start permitted only if NEC code max does not allow motor start-up. For high reverse/jog/plug applications, larger horsepower motors.

Class CFTCF CUBEFuse and Class CC Low-Peak (LP-CC) fuses provide excellent motor branch circuit short-circuit protection. The TCF CUBEFuse has good time-delay characteristics and the amp rating can be sized the same as a Class J time-delay fuse up to 400 amps (generally can be sized at 150 to 175% of motor FLA).

Low-Peak LP-CC fuses are the suggested Class CC fuses for motor branch circuit short-circuit protection. Due to their small size, the time-delay is not as robust as the TCF CUBEFuse and therefore the amp rating sizing suggestions need to be greater (generally 200% of the motor FLA up to LP-CC 15 A and 300% of the motor FLA for LP-CC 20 to 30 A).

TCF time-delay Class CF CUBEFuses

Voltage	Motor size (Hp)	Motor FLA (amps)	Min (amps)	NEC code max (amps)	Heavy start* (amps)
115 Vac, 1-phase	1/6	4.4	10	10	10
	1/4	5.8	10	15	15
	1/3	7.2	15	15	15
	1/2	9.8	15	20	20
	3/4	13.8	25	25	30
	1	16	25	30	35
	1-1/2	20	30	35	45
	2	24	40	45	50
	3	34	50	60	70
	5**	56	90	100	125
230 Vac, 1-phase	7-1/2	80	125	150	175
	10	100	150	175	225
	1/6	2.2	6	6	6
	1/4	2.9	6	6	6
	1/3	3.6	6	10	10
	1/2	4.9	10	10	10
	3/4	6.9	15	15	15
	1	8	15	15	17.5
	1-1/2	10	15	20	20
	2	12	20	25	25
200 Vac, 3-phase	3	17	25	30	35
	5	28	45	50	60
	7-1/2	40	60	70	90
	10**	50	80	90	110
	1/2	2.5	6	6	6
	3/4	3.7	6	10	10
	1	4.8	10	10	10
	1-1/2	6.9	15	15	15
	2	7.8	15	15	17.5
	3	11	17.5	20	20
200 Vac, 3-phase	5	17.5	30	35	35
	7-1/2	25.3	40	45	50
	20**	62.1	100	110	125
	25	78.2	125	150	175
	30	92	150	175	200
	40	120	200	225	250
	50	150	225	300	300
	60	177	300	350	350

Note: Use NEC code max column for low to moderate reverse/jog/plug applications.

* Heavy Start permitted only if NEC code max does not allow motor start-up.
 **If equipment terminations are rated for 60°C conductors only, the 60°C conductor ampacities must be utilized and therefore larger conductor sizes or conduit sizes may be required.

Voltage	Motor size (Hp)	Motor FLA (amps)	Min (amps)	NEC code max (amps)	Heavy start* (amps)
208 Vac, 3-phase	1/2	2.4	6	6	6
	3/4	3.5	6	10	10
	1	4.6	10	10	10
	1-1/2	6.6	10	15	15
	2	7.5	15	15	15
	3	10.6	17.5	20	20
	5	16.7	25	30	35
	7-1/2	24.2	40	45	50
	20**	59.4	90	110	125
	25	74.8	125	150	150
	30	88	150	175	175
	40	114	175	200	250
	50	143	225	300	300
	60	169	300	300	350
	1/2	2.2	6	6	6
3/4	3.2	6	6	6	
1	4.2	10	10	10	
1-1/2	6	10	15	15	
2	6.8	15	15	15	
3	9.6	15	20	20	
5	15.2	25	30	30	
7-1/2	22	35	40	45	
20**	54	90	100	110	
25	68	110	125	150	
30	80	125	150	175	
40	104	175	200	225	
50	130	200	250	250	
60	154	250	300	300	
75	192	300	350	400	
1/2	1.1	3	3	3	
3/4	1.6	3	3	3	
1	2.1	6	6	6	
1-1/2	3	6	6	6	
2	3.4	6	6	6	
3	4.8	10	10	10	
5	7.6	15	15	15	
7-1/2	11	17.5	20	20	
10	14	25	25	30	
15	21	35	40	45	
20	27	40	50	60	
50**	65	100	125	125	
60	77	125	150	150	
75	96	150	175	200	
100	124	200	225	250	
125	156	250	300	350	
150	180	300	350	400	

Voltage	Motor size (Hp)	Motor FLA (amps)	Min (amps)	NEC code max (amps)	Heavy start* (amps)
575 Vac, 3-phase	1/2	0.9	3	3	3
	3/4	1.3	3	3	3
	1	1.7	3	3	3
	1-1/2	2.4	6	6	6
	2	2.7	6	6	6
	3	3.9	6	10	10
	5	6.1	10	15	15
	7-1/2	9	15	20	20
	10	11	17.5	20	20
	40**	41	70	80	80
	50	52	80	100	110
	60	62	100	110	125
	75	77	125	150	150
	100	99	150	175	200
	125	125	200	225	250
150	144	225	300	300	
200	192	300	350	400	

Note: Use NEC code max column for low to moderate reverse/jog/plug applications.

* Heavy Start permitted only if NEC code max does not allow motor start-up.
 **If equipment terminations are rated for 60°C conductors only, the 60°C conductor ampacities must be utilized and therefore larger conductor sizes or conduit sizes may be required.

Note: Use NEC code max column for low to moderate reverse/jog/plug applications.

* Heavy Start permitted only if NEC code max does not allow motor start-up.
 **If equipment terminations are rated for 60°C conductors only, the 60°C conductor ampacities must be utilized and therefore larger conductor sizes or conduit sizes may be required.

Customer satisfaction team:

Available to answer questions regarding Bussmann series products and services Monday-Friday, 7:00 a.m. — 6:00 p.m. Central Time.

- Toll-free phone: 855-287-7626 (855-BUSSMANN)
- Toll-free fax: 800-544-2570
- Email: BussCustSat@Eaton.com

Emergency and after-hours orders:

Next flight out or will call shipment for time-critical needs. Customers pay only standard product price, rush freight charges, and modest emergency service fee. Place these orders through the customer satisfaction team during regular business hours.

- After hours: 314-995-1342

My.Eaton.com:

Provides real time product availability, net pricing, order status and shipment tracking. Log onto My.Eaton.com or call:

- 1-800-468-1705 Option #3 for log-in assistance.

Application engineering:

Technical assistance is available to all customers. Application support is available Monday-Friday, 7:00 a.m. — 5:00 p.m. Central Time.

- Toll-free phone: 855-287-7626 (855-BUSSMANN)
- Email: FuseTech@Eaton.com

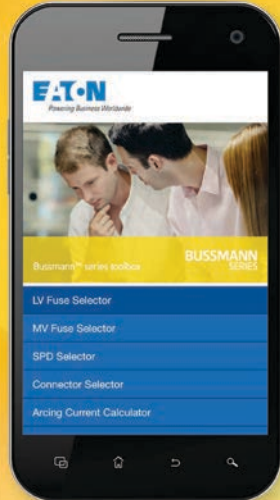

Bussmann series toolbox

All the tools you need, in the palm of your hand.

- > FC² Available Fault Current Calculator
- > Arcing Current Calculator
- > Low Voltage Fuse Selector
- > Medium Voltage Fuse Selector
- > Motor Protection Selector
- > Surge Protective Device Selector
- > Connector Selector
- > Competitor Cross Reference
- > Distributor Locator
- > SCCR Protection Suite
- > OSCAR™ 2.1 Online Compliance Software
- > Selective Coordination Designer v1.0
- > RoHS Compliance Product Search

<http://toolbox.bussmann.com>

Eaton
1000 Eaton Boulevard
Cleveland, OH 44122
Eaton.com

Bussmann Division
114 Old State Road
Ellisville, MO 63021
United States
Eaton.com/bussmannseries

© 2019 Eaton
All Rights Reserved
Printed in USA
Publication No. 7038
January 2019

Eaton, Bussmann, Compact Circuit Protector, Low-Peak, CUBEFuse, and Quik-Spec are valuable trademarks of Eaton in the US and other countries. You are not permitted to use the Eaton trademarks without prior written consent of Eaton.

NEC is a registered trademark of the National Fire Protection Association, Inc.
NFPA is a registered trademark of the National Fire Protection Association, Inc.
UL is a registered trademark of the Underwriters Laboratories, Inc.

For Eaton's Bussmann series product information, call **1-855-287-7626** or visit: **Eaton.com/bussmannseries**

Follow us on social media to get the latest product and support information.



X-ON Electronics

Largest Supplier of Electrical and Electronic Components

Click to view similar products for [Circuit Breaker Accessories](#) category:

Click to view products by [Eaton](#) manufacturer:

Other Similar products are found below :

[CSC-403PS](#) [8T1-D-11A](#) [8T1-E-125](#) [B151-7184-L](#) [8C1-C-721](#) [8T1-E-115](#) [8T1-E-275](#) [8T1-E-278](#) [506-11315-001](#) [3803221](#) [X10506BF](#) [NES](#)
[9-1393249-0](#) [802-ESB50UL489](#) [XFPB-4](#) [30.329](#) [X22261102](#) [CX2.5/4/O](#) [Y30019003](#) [PS-1006](#) [618.6335.069](#) [BAC03](#) [JX2.5/4](#) [JX2.5/6](#)
[JX2.5/5](#) [HSP6/10U](#) [DMRBU BLACK BOX](#) [DB16/BU](#) [CM2.5S2](#) [932146100](#) [930120000](#) [601.1231.909](#) [3PRG1](#) [3PLBR4LU](#) [351.5900.149](#)
[311.2850.340](#) [2624.0](#) [17BSSV](#) [1-1423696-8](#) [LS3-WH](#) [BAC12](#) [30.617](#) [8T1-E-114](#) [SF06-5,08](#) [PLLA3](#) [2LP199](#) [ZG20-2](#) [3PSML401](#)
[3PSML402](#) [2LP219](#)