

PART NO.	COLOR	PANTONE #
DS20-GY-ND	GREY	COOL GRAY2U
DS20-RD-ND	RED	1805U
DS20-OR-ND	ORANGE	152U
DS20-YW-ND	YELLOW	7404U
DS20-GN-ND	GREEN	362U
DS20-BU-ND	BLUE	300U
DS20-LK-ND	BLACK	BLACK

REVISIONS					
REV	ZONE	DESCRIPTION	DATE	ECN	BY
A	-	INITIAL RELEASE	09/24/2012	BU-SB12870	TJN

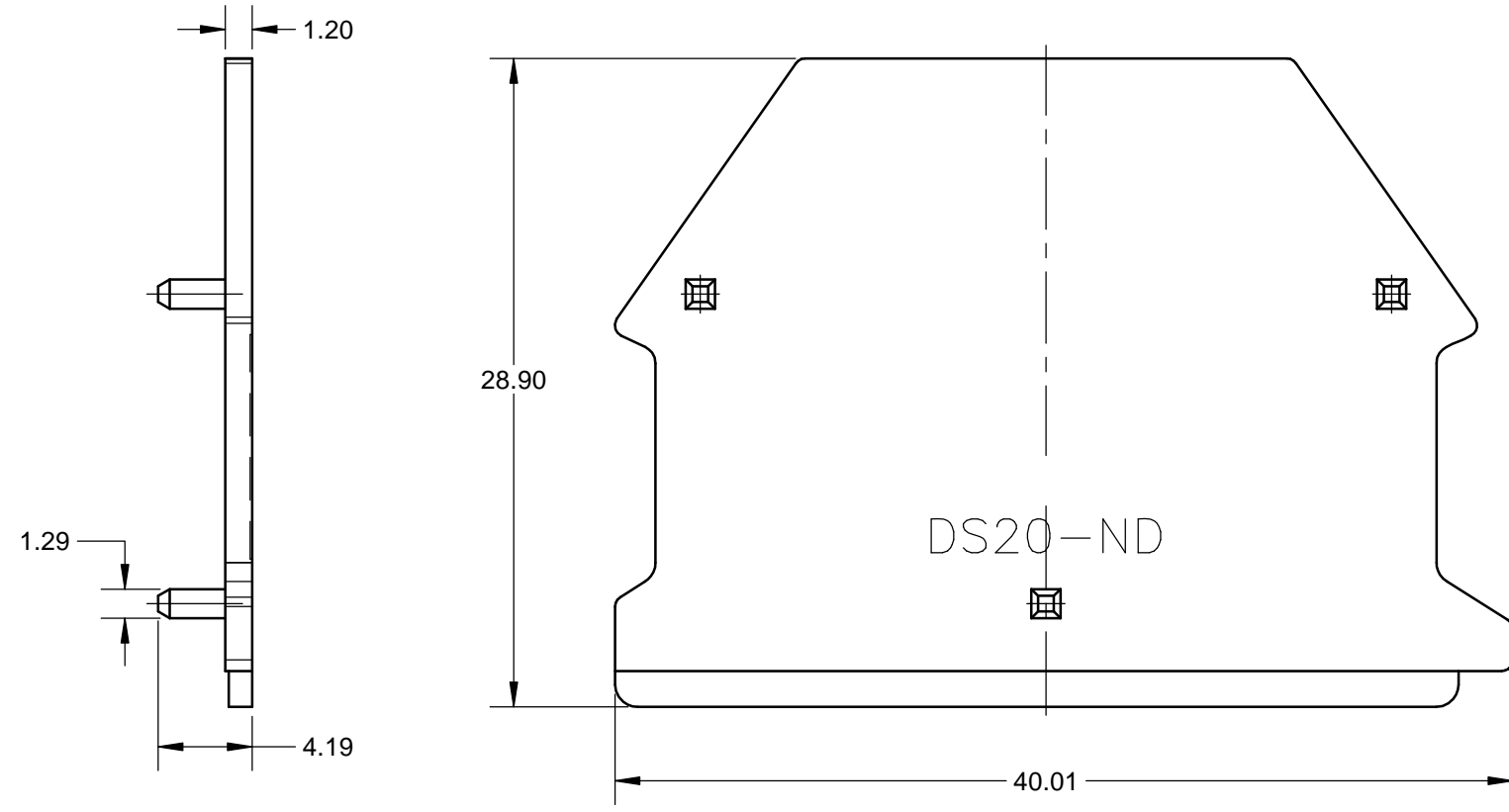
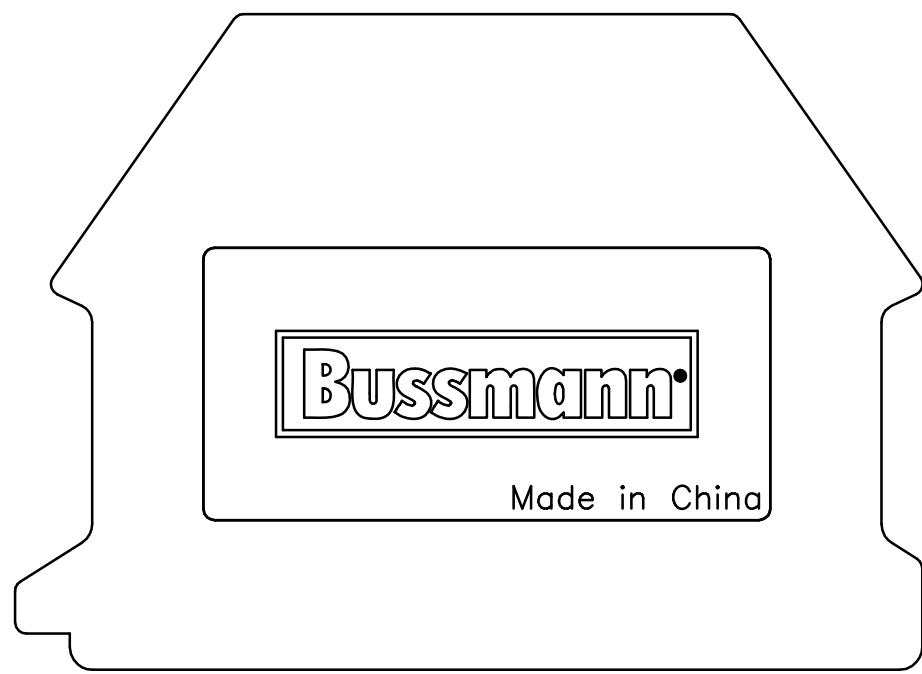

- NOTES:
- MATERIAL: PA66; UL94-V0 RATING
  - ASSEMBLY MUST BE FREE OF OIL, GREASE AND OTHER FOREIGN MATERIALS.
  - ASSEMBLY MUST COMPLY WITH RoHS SPECIFICATION #1P2163.

MODEL SOURCE DATA --	MODEL VERSION	GENERAL DRAWING PRACTICES IN ACCORDANCE WITH ASME - Y14.100-2004 DIMENSIONS AND TOLERANCES IN ACCORDANCE WITH ASME - Y14.5M-1994	APPROVALS ENGINEER: TJN DRAWN: TJN MANUFACTURING ENGINEER: -- MATERIAL: SEE TABLE FINISH: N/A	DATE 09/26/2012 09/26/2012 --/--/----	<p>St. Louis, MO 63178 (USA)</p>
<p>THIS DRAWING IS AN UNCONTROLLED COPY IF PRINTED OR SENT ELECTRONICALLY. DO NOT SCALE DRAWING</p> <p>CONFIDENTIAL. THE INFORMATION CONTAINED IN THIS DOCUMENT IS THE PROPERTY OF COOPER INDUSTRIES, INC. IT IS NOT FOR PUBLIC DISCLOSURE. POSSESSION OF THE INFORMATION DOES NOT CONVEY ANY RIGHT TO LOAN, SELL, OR DISCLOSE THE INFORMATION. UNAUTHORIZED REPRODUCTION OR USE OF THE INFORMATION IS PROHIBITED. THIS DOCUMENT IS TO BE RETURNED TO COOPER INDUSTRIES, INC. UPON COMPLETION OF THE PURPOSE FOR WHICH IT WAS LOANED OR UPON REQUEST.</p> <p>COPYRIGHT. COOPER INDUSTRIES, INC. THIS IS AN UNPUBLISHED WORK. THE DISCLOSURE OF THIS WORK IS LIMITED TO SELECT PERSONNEL. FURTHER DISSEMINATION OR DISCLOSURE TO THE PUBLIC IS PROHIBITED. THIS UNPUBLISHED WORK IS PROTECTED BY FEDERAL COPYRIGHT LAW AND ALL RIGHTS THEREUNDER ARE RESERVED BY COOPER INDUSTRIES, INC.</p>		<p>UNLESS OTHERWISE SPECIFIED DIMENSIONS ARE IN MILLIMETERS TOLERANCES TO BE</p> <p>ONE PLACE X.X = ±0.3mm TWO PLACE X.X X = ±0.13mm ALL ANGLES X.X = ±1°</p> <p>SPECIAL CHARACTERISTIC <math>\diamond (0)</math> SIGNIFICANT CHARACTERISTIC <math>\triangle (0)</math></p> <p>THIRD ANGLE PROJECTION</p>	<p>TITLE <b>END COVER</b></p> <p>SIZE DWG NO. <b>A3 DS20-XX-ND</b></p> <p>SCALE: 3:1 SHEET 1 OF 1</p>	REV <b>A</b>	

## X-ON Electronics

Largest Supplier of Electrical and Electronic Components

*Click to view similar products for [Circuit Breaker Accessories](#) category:*

*Click to view products by [Eaton](#) manufacturer:*

Other Similar products are found below :

[CSC-403PS](#) [8T1-D-11A](#) [B151-7184-L](#) [NEB10](#) [8C1-C-721](#) [8T1-E-115](#) [8T1-E-275](#) [8T1-E-278](#) [4-1393247-8](#) [4-1393247-9](#) [506-11315-001](#)  
[3803221](#) [3803231](#) [NEB6](#) [X10506BF](#) [NES](#) [9-1393249-0](#) [802-ESB50UL489](#) [3RV2011-1CA15](#) [607.5689.127](#) [30.329](#) [CA707/TS/01](#)  
[11-32-2733](#) [X10508BF](#) [X22261102](#) [975090700](#) [CX2.5/4/O](#) [975090701](#) [PS-2P](#) [Y30019003](#) [C-TEC1225 P](#) [PS-1006](#) [618.6335.069](#)  
[975455700](#) [BAC03](#) [930727103](#) [934097101](#) [ZG20-1](#) [934097100](#) [JX2.5/4](#) [KEM380CUL](#) [CC848756916](#) [JX2.5/6](#) [JX2.5/5](#) [HSP6/10U](#)  
[DMRBU BLACK BOX](#) [DB16/BU](#) [DB16/BL](#) [CM2.5S2](#) [973604100](#)