

# MCL1608V2

## Multilayer chip inductor



### Product features

- 0603 (1608 metric) package
- High self resonant frequency (SRF)
- Multilayer monolithic construction yields high reliability
- Suitable for wave and reflow soldering
- Inductance range from 1.0 nH to 470 nH
- Moisture sensitivity level (MSL): 1

### Applications

- Industrial connectivity (IoT)
- Wireless communications
  - Bluetooth
  - WiFi
  - Antenna
- Machine-to-machine (M2M)
- Mobile phones
- Wearable devices
- Wireless LAN
- Computing/gaming consoles
- Broadband components
- RF transceiver modules

### Environmental data

- Operating temperature range: -40 °C to +85 °C (ambient plus self-temperature rise)
- Solder reflow temperature: J-STD-020 (latest revision) compliant



Product specifications

Part number	OCL (nH) ±5%	I Rated (mA) maximum	DCR (Ω) maximum @ +25°C	SRF (MHz) minimum	Q minimum	Test frequency (MHz)	Test voltage (mV)
MCL1608V2-1R0-R	1.0 ±0.3nH	500	0.05	10000	8	100	50
MCL1608V2-1R2-R	1.2 ±0.3nH	500	0.05	10000	8	100	50
MCL1608V2-1R5-R	1.5 ±0.3nH	500	0.10	6000	8	100	50
MCL1608V2-1R8-R	1.8 ±0.3nH	500	0.10	6000	8	100	50
MCL1608V2-2R2-R	2.2 ±0.3nH	500	0.10	6000	8	100	50
MCL1608V2-2R7-R	2.7 ±0.3nH	500	0.12	6000	10	100	50
MCL1608V2-3R3-R	3.3± 0.3nH	500	0.15	6000	10	100	50
MCL1608V2-3R9-R	3.9 ±0.3nH	500	0.16	6000	10	100	50
MCL1608V2-4R7-R	4.7 ±0.3nH	500	0.20	6000	10	100	50
MCL1608V2-5R6-R	5.6 ±0.3nH	500	0.25	5000	10	100	50
MCL1608V2-6R8-R	6.8	500	0.30	5000	10	100	50
MCL1608V2-8R2-R	8.2	500	0.35	4500	10	100	50
MCL1608V2-100-R	10.0	300	0.40	3500	12	100	50
MCL1608V2-120-R	12.0	300	0.45	3000	12	100	50
MCL1608V2-150-R	15.0	300	0.50	2300	12	100	50
MCL1608V2-180-R	18.0	300	0.55	2200	12	100	50
MCL1608V2-220-R	22.0	300	0.60	2000	12	100	50
MCL1608V2-270-R	27.0	300	0.65	1700	12	100	50
MCL1608V2-330-R	33.0	300	0.70	1500	12	100	50
MCL1608V2-390-R	39.0	300	0.70	1400	12	100	50
MCL1608V2-470-R	47.0	300	0.70	1200	12	100	50
MCL1608V2-560-R	56.0	300	0.75	1100	12	100	50
MCL1608V2-680-R	68.0	300	0.85	900	12	100	50
MCL1608V2-820-R	82.0	300	1.00	800	8	100	50
MCL1608V2-101-R	100	300	1.20	700	8	100	50
MCL1608V2-121-R	120	200	1.40	600	8	100	50
MCL1608V2-151-R	150	200	1.60	500	8	100	50
MCL1608V2-181-R	180	200	1.90	400	8	100	50
MCL1608V2-221-R	220	200	2.40	350	8	100	50
MCL1608V2-271-R	270	150	2.60	350	8	100	50
MCL1608V2-331-R	330	150	2.80	350	8	100	50
MCL1608V2-391-R	390	150	3.20	300	8	100	50
MCL1608V2-431-R	430	150	3.40	280	8	50	50
MCL1608V2-471-R	470	150	3.60	250	8	50	50

1. Test frequency and voltage are for OCL and Q at +25 °C
2. Resistance to soldering heat: +260 ±5 °C for 10 ± 1 second
3. At low temperature resistance (-40 ±2°C) the inductance change is within ±10% and the Q within ±20%
4. At high temperature resistance (+85 ±2°C) the inductance change is within ±10% and the Q within ±20%

5. At high temperature load (+85 ±2°C) the inductance change is within ±10% and the Q within ±20%
6. Rated I: When rated I is applied to the product, self-temperature rise will be 40 °C or less.
7. Part Number Definition: MCL1608V2-xxx-R  
MCL1608 = Product code and size  
V2= Version indicator  
xxx= inductance value in nH, R= decimal point,  
If no R is present then last character equals number of zeros  
-R suffix = RoHS compliant

Dimensions (mm)



Schematic



Part Number	L	W	T	a	A	B	C
MCL1608V2-xxx-R	1.6 ±0.20	0.80 ±0.20	0.80 ±0.20	0.30 ±0.20	1.2 ±0.10	0.9 ±0.10	04 ±0.10

No part marking  
 All soldering surfaces to be coplanar within 0.1 millimeters  
 Tolerances are ±0.2 millimeters unless stated otherwise  
 Pad layout tolerances are ±0.1 millimeters unless stated otherwise  
 Do not route traces or vias underneath the inductor

Packaging information (mm)

Drawing not to scale

Supplied in tape and reel packaging, 4000 parts per 7" diameter reel

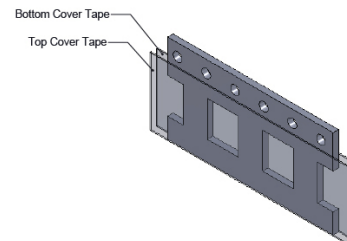
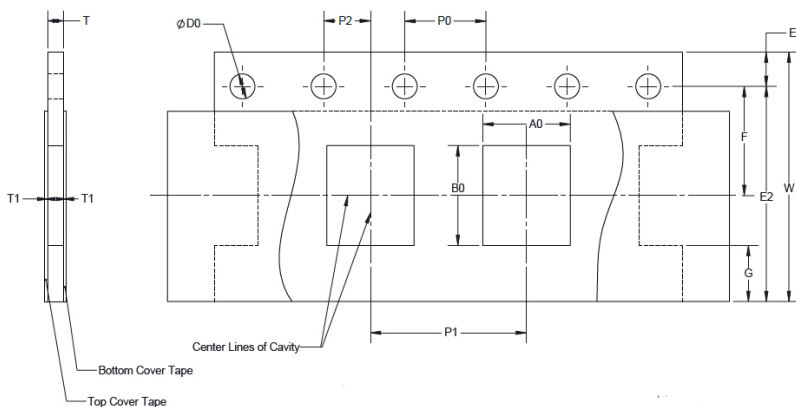

W ±0.3	8.00
F ±0.05	3.50
E1 ±0.10	1.75
E2 Min	6.25
P0 ±0.10	4.00
P1 ±0.2	4.00
P2 ±0.1	2.00
D0 +0.10/-0	1.50
A0	1.1 ±0.20
B0	1.9 ±0.20
T Max	1.10
T1 Max	na

**Inductance vs frequency**

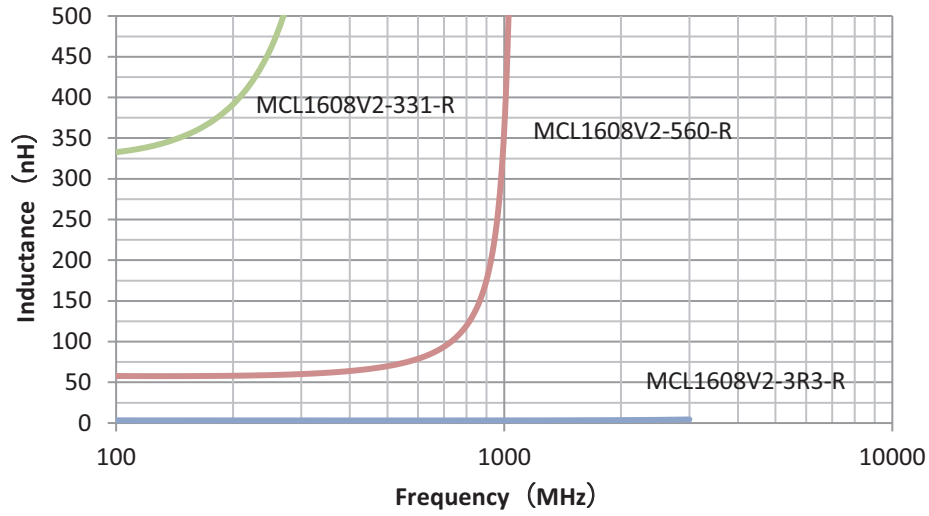

**Q vs frequency**

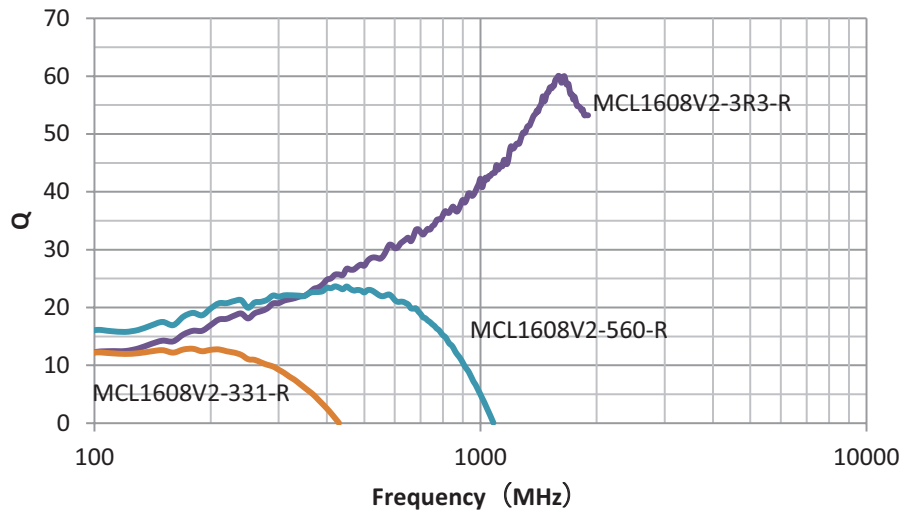

Solder reflow profile

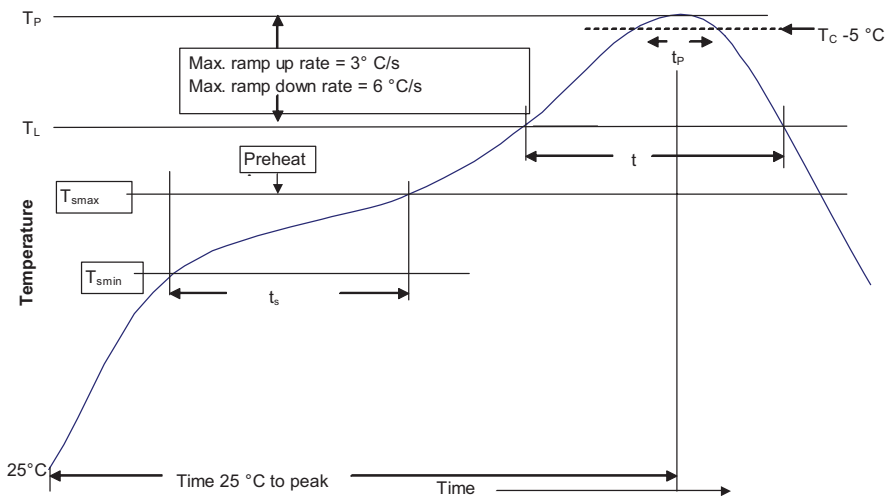

Table 1 - Standard SnPb solder ( $T_C$ )

Package Thickness	Volume mm <sup>3</sup> <350	Volume mm <sup>3</sup> ≥350
<2.5 mm)	235 °C	220 °C
≥2.5 mm	220 °C	220 °C

Table 2 - Lead (Pb) free solder ( $T_C$ )

Package thickness	Volume mm <sup>3</sup> <350	Volume mm <sup>3</sup> 350 - 2000	Volume mm <sup>3</sup> >2000
<1.6 mm	260 °C	260 °C	260 °C
1.6 – 2.5 mm	260 °C	250 °C	245 °C
>2.5 mm	250 °C	245 °C	245 °C

Reference J-STD-020

Profile feature	Standard SnPb solder	Lead (Pb) free solder
Preheat and soak		
• Temperature min. ( $T_{smin}$ )	100 °C	150 °C
• Temperature max. ( $T_{smax}$ )	150 °C	200 °C
• Time ( $T_{smin}$ to $T_{smax}$ ) ( $t_s$ )	60-120 seconds	60-120 seconds
Average ramp up rate $T_{smax}$ to $T_p$	3 °C/ second max.	3 °C/ second max.
Liquidous temperature ( $T_L$ )	183 °C	217 °C
Time at liquidous ( $t_L$ )	60-150 seconds	60-150 seconds
Peak package body temperature ( $T_p$ )*	Table 1	Table 2
Time ( $t_p$ )** within 5 °C of the specified classification temperature ( $T_C$ )	10 seconds**	10 seconds**
Average ramp-down rate ( $T_p$ to $T_{smax}$ )	6 °C/ second max.	6 °C/ second max.
Time 25 °C to peak temperature	6 minutes max.	8 minutes max.

\* Tolerance for peak profile temperature ( $T_p$ ) is defined as a supplier minimum and a user maximum.

\*\* Tolerance for time at peak profile temperature ( $t_p$ ) is defined as a supplier minimum and a user maximum.

### Wave solder profile



### Reference EN 61760-1:2006

Profile feature	Standard SnPb solder	Lead (Pb) free solder
Preheat		
• Temperature min. ( $T_{smin}$ )	100 °C	100 °C
• Temperature typ. ( $T_{styp}$ )	120 °C	120 °C
• Temperature max. ( $T_{smax}$ )	130 °C	130 °C
• Time ( $T_{smin}$ to $T_{smax}$ ) ( $t_s$ )	70 seconds	70 seconds
$\Delta$ preheat to max Temperature	150 °C max.	150 °C max.
Peak temperature ( $T_p$ )*	235 °C – 260 °C	250 °C – 260 °C
Time at peak temperature ( $t_p$ )	10 seconds max 5 seconds max each wave	10 seconds max 5 seconds max each wave
Ramp-down rate	~ 2 K/s min ~3.5 K/s typ ~5 K/s max	~ 2 K/s min ~3.5 K/s typ ~5 K/s max
Time 25 °C to 25 °C	4 minutes	4 minutes

### Manual solder

+350 °C, 4-5 seconds. (by soldering iron), generally manual, hand soldering is not recommended.

Life Support Policy: Eaton does not authorize the use of any of its products for use in life support devices or systems without the express written approval of an officer of the Company. Life support systems are devices which support or sustain life, and whose failure to perform, when properly used in accordance with instructions for use provided in the labeling, can be reasonably expected to result in significant injury to the user.

Eaton reserves the right, without notice, to change design or construction of any products and to discontinue or limit distribution of any products. Eaton also reserves the right to change or update, without notice, any technical information contained in this bulletin.

**Eaton**  
**Electronics Division**  
1000 Eaton Boulevard  
Cleveland, OH 44122  
United States  
[www.eaton.com/electronics](http://www.eaton.com/electronics)

© 2019 Eaton  
All Rights Reserved  
Printed in USA  
Publication No. 10927 BU-MC19059  
June 2019

Eaton is a registered trademark.

All other trademarks are property of their respective owners.

Follow us on social media to get the latest product and support information.



## X-ON Electronics

Largest Supplier of Electrical and Electronic Components

*Click to view similar products for [RF inductors - SMD category](#):*

*Click to view products by [Eaton manufacturer](#):*

Other Similar products are found below :

[MHL1ECTTP82NJ](#) [MHL1ECTTP8N2J](#) [CIH10T12NJNC](#) [B82498B1332J000](#) [B82498B3121J000](#) [0805WL220GT](#) [1008WL101GT](#)  
[0805WL681GT](#) [IWC0402D27NR-3G](#) [IWC0603F68NR-3G](#) [IWC0402AR10R-3G](#) [0603WL470JT](#) [IWC0402D33NR-3G](#) [IWC0603F47NR-3G](#)  
[0805WL151JT](#) [IWC0402A68NR-3G](#) [IWC0402AR12R-3G](#) [IWC0402A82NR-3G](#) [IWC0402B39NR-3G](#) [IWC0603CR12R-3G](#)  
[IWC0603AR33R-3G](#) [IWC0603BR18R-3G](#) [IWC0603F39NR-3G](#) [IWC0603BR22R-3G](#) [IWC0402A47NR-3G](#) [IWC0603AR27R-3G](#)  
[IWC0603F27NR-3G](#) [IWC1008DR68R-3G](#) [IWC1008FR12R-3G](#) [IWC1008FR18R-3G](#) [IWC1008J33NR-3G](#) [IWC1008J82NR-3G](#)  
[IWC1008DR47R-3G](#) [IWC1008J18NR-3G](#) [IWC0805E22NR-3G](#) [IWC1008DR82R-3G](#) [IWC0805E33NR-3G](#) [IWC1008J68NR-3G](#)  
[IWC0805D82NR-3G](#) [IWC0805DR10R-3G](#) [IWC0805E39NR-3G](#) [IWC1008DR39R-3G](#) [IWC0805DR15R-3G](#) [IWC1008J39NR-3G](#)  
[IWC1008J27NR-3G](#) [IWC0805DR18R-3G](#) [IWC0805E68NR-3G](#) [IWC1008ER27R-3G](#) [IWC1008FR10R-3G](#) [IWC1008J22NR-3G](#)