

MFHA

SMD current sensing resistor-metal film



Applications

- Switched-mode power supply (SMPS)
- Voltage regulator module
- Power management
- Stepper motor drives

Environmental compliance



Product features

- Low sensing resistance
- 1206 (3216 metric) to 2512 (6432 metric)
- High power dissipation
- AEC-Q200 compliant
- Moisture sensitivity level (MSL): 1

Table 1. Part numbering configuration scheme

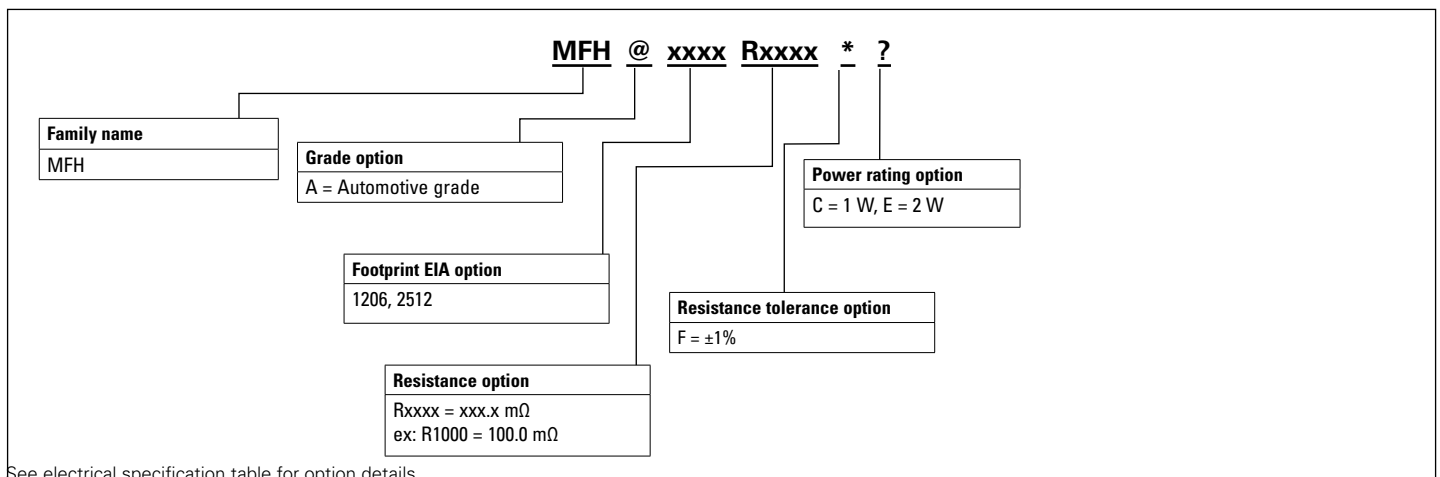

Mechanical parameters- Inches [mm]

Family	Size code	L	W	C	d	t
MFHA1206	1206 [3216]	0.126 ± 0.008 [3.20 ± 0.20]	0.063 ± 0.008 [1.60 ± 0.20]	0.020 ± 0.012 [0.50 ± 0.30]	0.016 ± 0.008 [0.40 ± 0.20]	0.022 ± 0.004 [0.55 ± 0.10]
MFHA2512	2512 [6432]	0.252 ± 0.008 [6.40 ± 0.20]	0.126 ± 0.008 [3.20 ± 0.20]	0.024 ± 0.012 [0.60 ± 0.30]	0.020 ± 0.010 [0.50 ± 0.25]	0.022 ± 0.004 [0.55 ± 0.10]

Part marking: Rxxx: (xxx= resistance value in ohms expressed in 3 digits, 100 = 0.100 Ω or 100 mΩ)

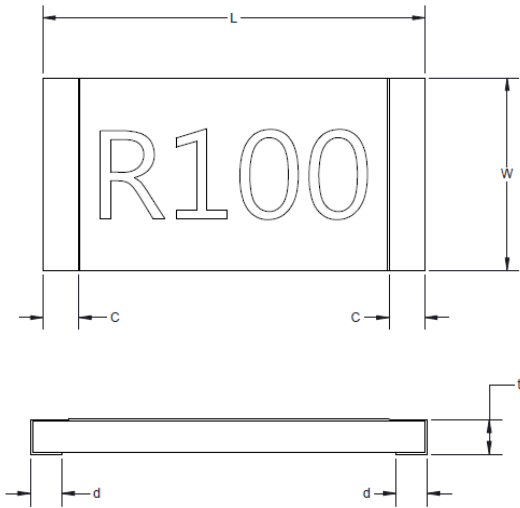

Recommended pad layout-mm

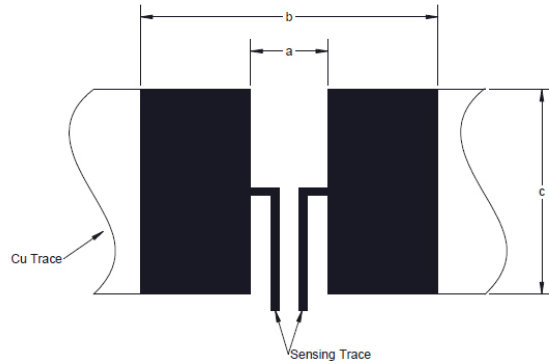

Construction

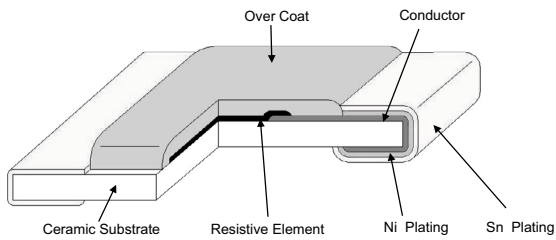

Family	a	b	c
MFHA1206	0.7	5.1	2.5
MFHA2512	1.0	7.5	4.2

1. The copper foil minimum thickness of PCB needs 3 oz.
2. Pad layout dimension tolerance is ±0.1 mm.
3. The resistance will change slightly after soldered; it is dependent on PCB pad size design and it's necessary to consider the effect of the resistance increase or decrease.

Electrical specifications

Part number	Size	Grade option	Resistance value mΩ (Part number code)	Resistance tolerance (Part number code)	Power rating (Part number code)	TCR (ppm/°C)	Operating temperature
MFH@1206Rxxxx*?	1206 (3216 metric)	A	100 (1000)	±1% (F)	1 W (C)	± 100	-55 °C to +155 °C
MFH@1206Rxxxx*?	1206 (3216 metric)	A	120 (1200)	±1% (F)	1 W (C)	± 100	-55 °C to +155 °C
MFH@1206Rxxxx*?	1206 (3216 metric)	A	150 (1500)	±1% (F)	1 W (C)	± 100	-55 °C to +155 °C
MFH@1206Rxxxx*?	1206 (3216 metric)	A	200 (2000)	±1% (F)	1 W (C)	± 100	-55 °C to +155 °C
MFH@1206Rxxxx*?	1206 (3216 metric)	A	220 (2200)	±1% (F)	1 W (C)	± 100	-55 °C to +155 °C
MFH@1206Rxxxx*?	1206 (3216 metric)	A	250 (2500)	±1% (F)	1 W (C)	± 100	-55 °C to +155 °C
MFH@1206Rxxxx*?	1206 (3216 metric)	A	270 (2700)	±1% (F)	1 W (C)	± 100	-55 °C to +155 °C
MFH@1206Rxxxx*?	1206 (3216 metric)	A	300 (3000)	±1% (F)	1 W (C)	± 100	-55 °C to +155 °C
MFH@1206Rxxxx*?	1206 (3216 metric)	A	400 (4000)	±1% (F)	1 W (C)	± 100	-55 °C to +155 °C
MFH@1206Rxxxx*?	1206 (3216 metric)	A	500 (5000)	±1% (F)	1 W (C)	± 100	-55 °C to +155 °C
MFH@1206Rxxxx*?	1206 (3216 metric)	A	510 (5100)	±1% (F)	1 W (C)	± 100	-55 °C to +155 °C
MFH@1206Rxxxx*?	1206 (3216 metric)	A	700 (7000)	±1% (F)	1 W (C)	± 100	-55 °C to +155 °C
MFH@2512Rxxxx*?	2512 (6432 metric)	A	100 (1000)	±1% (F)	2.0 W (E)	± 100	-55 °C to +155 °C
MFH@2512Rxxxx*?	2512 (6432 metric)	A	120 (1200)	±1% (F)	2.0 W (E)	± 100	-55 °C to +155 °C
MFH@2512Rxxxx*?	2512 (6432 metric)	A	130 (1300)	±1% (F)	2.0 W (E)	± 100	-55 °C to +155 °C
MFH@2512Rxxxx*?	2512 (6432 metric)	A	150 (1500)	±1% (F)	2.0 W (E)	± 100	-55 °C to +155 °C
MFH@2512Rxxxx*?	2512 (6432 metric)	A	180 (1800)	±1% (F)	2.0 W (E)	± 100	-55 °C to +155 °C
MFH@2512Rxxxx*?	2512 (6432 metric)	A	200 (2000)	±1% (F)	2.0 W (E)	± 100	-55 °C to +155 °C
MFH@2512Rxxxx*?	2512 (6432 metric)	A	240 (2400)	±1% (F)	2.0 W (E)	± 100	-55 °C to +155 °C
MFH@2512Rxxxx*?	2512 (6432 metric)	A	250 (2500)	±1% (F)	2.0 W (E)	± 100	-55 °C to +155 °C
MFH@2512Rxxxx*?	2512 (6432 metric)	A	270 (2700)	±1% (F)	2.0 W (E)	± 100	-55 °C to +155 °C
MFH@2512Rxxxx*?	2512 (6432 metric)	A	300 (3000)	±1% (F)	2.0 W (E)	± 100	-55 °C to +155 °C
MFH@2512Rxxxx*?	2512 (6432 metric)	A	360 (3600)	±1% (F)	2.0 W (E)	± 100	-55 °C to +155 °C
MFH@2512Rxxxx*?	2512 (6432 metric)	A	390 (3900)	±1% (F)	2.0 W (E)	± 100	-55 °C to +155 °C
MFH@2512Rxxxx*?	2512 (6432 metric)	A	450 (4500)	±1% (F)	2.0 W (E)	± 100	-55 °C to +155 °C
MFH@2512Rxxxx*?	2512 (6432 metric)	A	470 (4700)	±1% (F)	2.0 W (E)	± 100	-55 °C to +155 °C
MFH@2512Rxxxx*?	2512 (6432 metric)	A	500 (5000)	±1% (F)	2.0 W (E)	± 100	-55 °C to +155 °C
MFH@2512Rxxxx*?	2512 (6432 metric)	A	510 (5100)	±1% (F)	2.0 W (E)	± 100	-55 °C to +155 °C
MFH@2512Rxxxx*?	2512 (6432 metric)	A	680 (6800)	±1% (F)	2.0 W (E)	± 100	-55 °C to +155 °C
MFH@2512Rxxxx*?	2512 (6432 metric)	A	750 (7500)	±1% (F)	2.0 W (E)	± 100	-55 °C to +155 °C

@= Enter grade option from table above (A=Automotive)

Rxxxx = Enter resistance code option from table above xxx= resistance code (R1000 = 100.0 mΩ)

* = Enter resistance tolerance code from table above (F= ±1%)

? = Enter power rating code from table above (C= 1 W, E= 2.0 W)

Packaging information- mm

Supplied in tape and reel on a 7.0" diameter reel (EIA-481 compliant)

Size	Tape	Quantity
1206	7 inch paper	5K
2512	7 inch embossed	4K

Tape carrier and dimensions

Paper tape carrier drawing

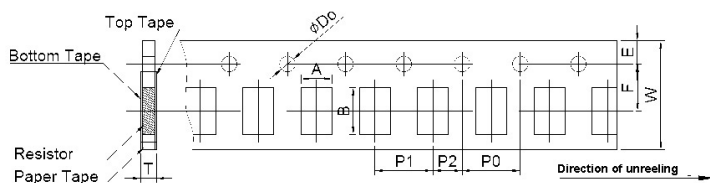

Embossed tape carrier drawing

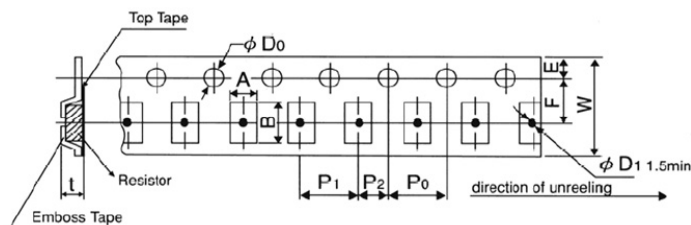

Dimension	1206	2512
E	1.75 ± 0.1	1.75 ± 0.1
F	3.5 ± 0.05	5.5 ± 0.05
P2	2.0 ± 0.1	2.0 ± 0.1
D0	1.5 ± 0.1	1.5 ± 0.1
P0	4.0 ± 0.1	4.0 ± 0.1
W	8.0 ± 0.1	12.0 ± 0.1
P1	4.0 ± 0.1	4.0 ± 0.1
A0	2.0 ± 0.15	3.6 ± 0.2
B0	3.6 ± 0.2	6.9 ± 0.2
T	0.84 ± 0.1	0.85 ± 0.15

Reel dimensions

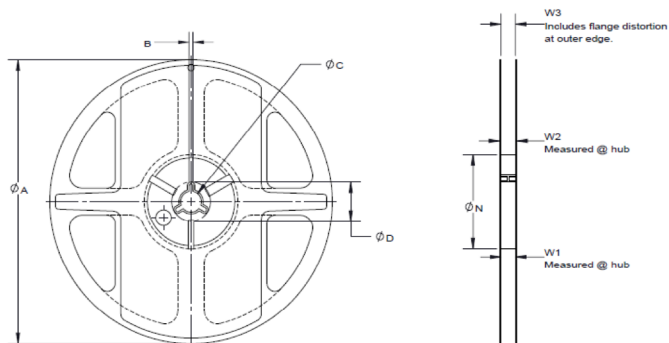

Size	A	B	C	D	N	W1	W2	W3
1206	178 ± 2.0	3.5 ± 0.5	13.0 ± 1.0	na	60 ± 1.0	9.0 ± 1.0	11.5 ± 1.0	na
2512	178 ± 2.0	3.5 ± 0.5	13.0 ± 1.0	na	60 ± 1.0	13.0 ± 1.0	15.5 ± 1.0	na

General specifications

Insulation resistance: > 100 MΩ
Temperature coefficient of resistance: IEC60115-1 4.8, +25 °C to +125 °C
Short time overload: IEC60115-1 4.13, 2.5 X rated power for 5 s
High temperature exposure (storage): AEC-Q200-REV D-test 3, MIL-STD202 Method 108, 1000 hours. @ +155 °C unpowered
Temperature cycling: AEC-Q200-REV D-Test 4, JESD22 Method JA-104, 1000 cycles (-55 °C to +155 °C), 30 minute maximum dwell time at each temperature extreme. 1 minute maximum transition time.
Biased humidity: AEC-Q200-REV D-Test 7, MIL-STD-202 method 103, 1000 hours +85 °C/85% RH. Note: Specified conditions: 10% of operating power (not exceeding max working voltage).
Operational life: AEC-Q200-REV D-Test 8, MIL-STD-202 method 108, 1000 hours, +125 °C at rated derating power.
Resistance to solvents: AEC-Q200-REV D-Test 12, MIL-STD-202 method 215, a: Isopropyl alcohol : mineral spirits= 1 : 3, b: Terpene defluxer (Bioact EC-7R) c: Deionized water : Propylene glycol Monomethyl ether : monoethanolamine = 42 : 1
Mechanical shock: AEC-Q200-REV D-Test 13, MIL-STD-202 Method 213, half sine shock pulse, peak value is 100 g's. Normal duration (D) is 6 (ms)
Vibration: AEC-Q200-REV D-Test 14, MIL-STD-202 method 204, 5 g's for 20 minutes, 12 cycles each of 3 orientations. Test from 10-2000 Hz
Resistance to soldering heat: AEC-Q200-REV D-Test 15, MIL-STD-202 method 210, Condition B : Immerse in eutectic solder at +260 °C ± 5 °C for 10 ± 1 second
Thermal shock: AEC-Q200-REV D-Test 16, MIL-STD-202 method 107, -55 °C/+155 °C. 300 cycles, Maximum transfer time 20 seconds, Dwell time 15 minutes. Air-Air
ESD: AEC-Q200-REV D-Test 17, AEC-Q200-002 or ISO/DIS 10605, verify the voltage setting at 500 V
Solderability: AEC-Q200-REV D-Test 18, J-STD-002, method B, aging 4 hours at +155 °C dry heat Lead-free solder bath at +235 °C ± 3 °C, Dipping time: 3 ± 0.5 seconds, > 95% area covered with tin
Flammability: AEC-Q200-REV D-Test 20, UL-94, Without plastic part, Use final goods burn with methane twice, each 10 s, Electrical test not required.
Board flex (bending): AEC-Q200-REV D-Test 21, AEC-Q200-005, The duration of the applied forces shall be 60 (+ 5) seconds, 2 mm deflection
Terminal strength (SMD): AEC-Q200-REV D-Test 22, AEC-Q200-006, Force of 1.8 kg for 60 seconds

Temperature derating curve

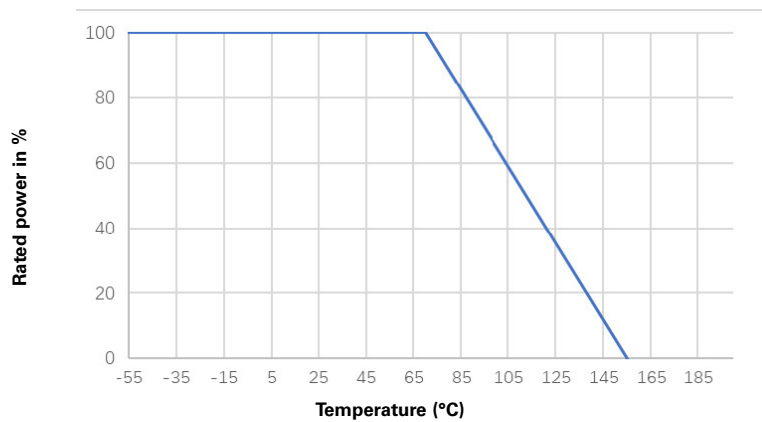

Rated current & voltage

The rated current and voltage are calculated by the following formula:

$$I = \sqrt{P \div R}$$

I: Rated current (A)

P: Rated power (W)

$$V = \sqrt{P \times R}$$

V: Rated voltage (V)

R: Resistance value (Ω)

Solder reflow profile

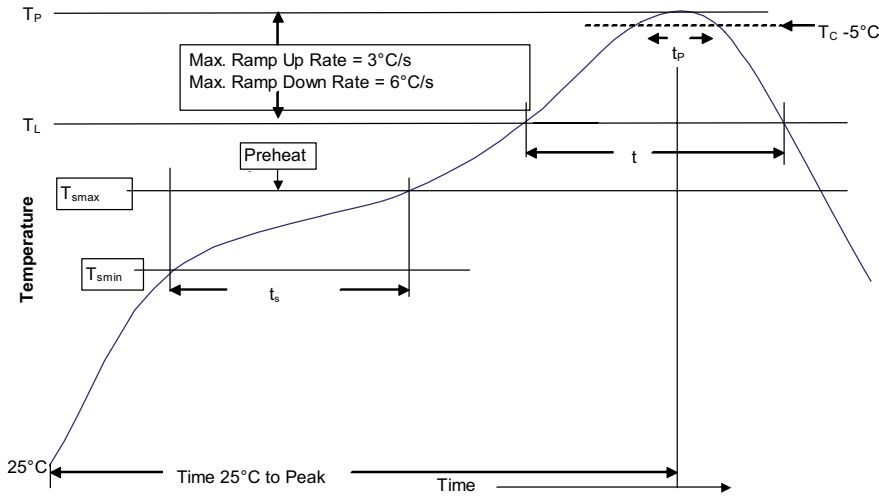

Profile feature	Lead (Pb) free solder	
Preheat and soak	<ul style="list-style-type: none"> • Temperature min. (T_{smin}) • Temperature max. (T_{smax}) • Time (T_{smin} to T_{smax}) (t_s) 	150 °C 200 °C 60-150 seconds
Ramp up rate T_L to T_p	3 °C/ second max.	
Liquidous temperature (T_L)	217 °C	
Time (t_L) maintained above T_L	60-120 seconds	
Peak package body temperature (T_p)*	260 °C	
Time (t_p)* within 5 °C of the specified classification temperature (T_c)	10 seconds*	
Ramp-down rate (T_p to T_L)	6 °C/ second max.	
Time 25 °C to peak temperature	8 minutes max.	

* Tolerance for peak profile temperature (T_p) is defined as a supplier minimum and a user maximum.

Manual solder

+350 °C ±10 °C , 3 +1/-0 seconds 1 time (by soldering iron), generally manual, hand soldering is not recommended

Life Support Policy: Eaton does not authorize the use of any of its products for use in life support devices or systems without the express written approval of an officer of the Company. Life support systems are devices which support or sustain life, and whose failure to perform, when properly used in accordance with instructions for use provided in the labeling, can be reasonably expected to result in significant injury to the user.

Eaton reserves the right, without notice, to change design or construction of any products and to discontinue or limit distribution of any products. Eaton also reserves the right to change or update, without notice, any technical information contained in this bulletin.

Eaton
Electronics Division
 1000 Eaton Boulevard
 Cleveland, OH 44122
 United States
 Eaton.com/electronics

© 2022 Eaton
 All Rights Reserved
 Printed in USA
 Publication No. ELX1178 BU-ELX22038
 June 2022

Eaton is a registered trademark.

All other trademarks are property of their respective owners.

Follow us on social media to get the latest product and support information.



X-ON Electronics

Largest Supplier of Electrical and Electronic Components

Click to view similar products for [Current Sense Resistors - SMD category](#):

Click to view products by [Eaton manufacturer](#):

Other Similar products are found below :

[CRL0603-FW-R700ELF](#) [PFS35-200RF1](#) [CD2015FC-0.10-1%](#) [PR2512FKF7W0R004L](#) [RC1005F124CS](#) [CSNL2512FT5L00](#)

[RL73K3AR56JTDF](#) [RL7520WT-R001-F](#) [RL7520WT-R020-F](#) [LRC-LR2512LF-01-R820J](#) [65709-330](#) [SP1R12J](#) [RL7520WT-R039-G](#)

[RL7520WT-R002-F](#) [RL7520WT-R005-F](#) [KRL1632E-C-R200-F-T5](#) [KRL1632E-C-R200-F-T1](#) [Y14880R02000B9R](#) [RLP73M2AR075FTDF](#)

[SR731ERTTP5R10F](#) [SR731ERTTP100J](#) [SR731ERTTP6R80F](#) [SR731ERTTP3R9J](#) [SR731ERTTP8R2J](#) [SR731ERTTP2R0J](#)

[SR731ERTTP4R7J](#) [SR731ERTTP9R1J](#) [SR731ERTTP1R0J](#) [SR731ERTTP2R2J](#) [SR731ERTTP5R1J](#) [SR731ERTTP6R8J](#) [SR731ERTTP9R10F](#)

[FCSL64R007JER](#) [73L4R10G](#) [73L4R75G](#) [73L4R33G](#) [73M1R051F](#) [73WL4R020J](#) [73L2R68J](#) [73L2R22J](#) [73L2R33J](#) [CC1512FC-0.015-5%](#)

[ULRG2-2512-R0075-F-LF-SLT](#) [KDV08DR220ET](#) [KDV12DR240ET](#) [SLN3TTED80L6F](#) [JW104X15X4](#) [JW105X19X5](#) [HVR06FTEV2403](#)

[JW104X5X4](#)