

RL0607

Unshielded radial leaded drum core inductors



Applications

- LED Drivers and lighting
- Utility meters
- Appliances and white goods
- Motor drives
- Power supplies
- General purpose filtering

Environmental data

- Storage temperature range (Component):
-40 °C to +125 °C
- Operating temperature range: 40 °C to +125 °C
(ambient plus self-temperature rise)

Product features

- Unshielded, leaded drum core
- Protective sleeving over winding
- Inductance range from 6.8 μ H to 1500 μ H
- Current range from 0.12 A to 2.23 A
- 5.7 mm OD \times 7.3 mm through-hole package
- Ferrite core material



Discontinued effective June 15, 2018
or until inventory is depleted.
No recommended replacement available.

Product specifications

Part Number ⁴	OCL ¹ (μH) $\pm 10\%$	I_{rms}^2 (A)	I_{sat}^3 (A)	DCR (Ω) @ +20 °C max.	SRF (MHz) typ.
RL0607-6R8-R	6.8 $\pm 20\%$	2.23	1.82	0.038	26
RL0607-100-R	10	1.82	1.51	0.058	21
RL0607-180-R	18	1.52	1.13	0.083	16
RL0607-330-R	33	1.08	0.840	0.171	11
RL0607-470-R	47	0.953	0.690	0.217	8
RL0607-820-R	82	0.686	0.530	0.426	6
RL0607-151-R	150	0.520	0.390	0.730	4
RL0607-221-R	220	0.423	0.320	1.10	3
RL0607-471-R	470	0.306	0.220	2.00	2
RL0607-821-R	820	0.219	0.170	4.13	2
RL0607-102-R	1000	0.205	0.150	7.70	1
RL0607-152-R	1500	0.166	0.120	7.20	1

- Open Circuit Inductance (OCL) Test Parameters: 10 kHz, 0.1 V_{rms} , 0.0Adc, +25 °C
- I_{rms} : DC current for an approximate temperature rise of 40 °C without core loss. Derating is necessary for AC currents. PCB layout, trace thickness and width, air-flow, and proximity of other heat generating components will affect the temperature rise. It is recommended that the temperature of the part not exceed +125 °C under worst case operating conditions verified in the end application.

- I_{sat} : Peak current for approximately 5% rolloff at +25 °C
- Part Number Definition: RL0607-yyy-R
 - RL0607 = Product code and size
 - yyy = inductance value in μH , R = decimal point
 - if no R is present then third character = number of zeros.
 - R" suffix = RoHS compliant

Dimensions - mm

Top view

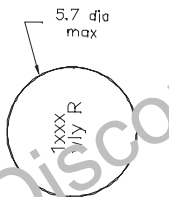

Side view

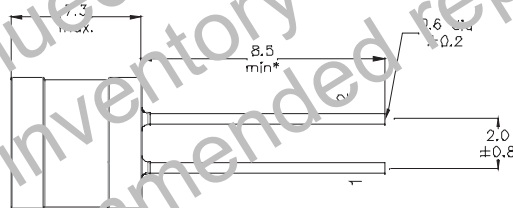

Recommended pad layout

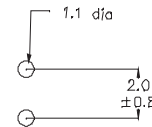

Schematic

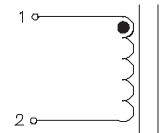

Part marking: 1xxx/wly R
 1 = RL0607
 xxx = inductance in μH , R = decimal point; if there is no R, then third character = number of zeros
 wly = date code, R = revision level

*Lead length is after the components are trimmed from the packaging tape roll.
 Do not route traces or vias underneath the inductor

Packaging information - mm

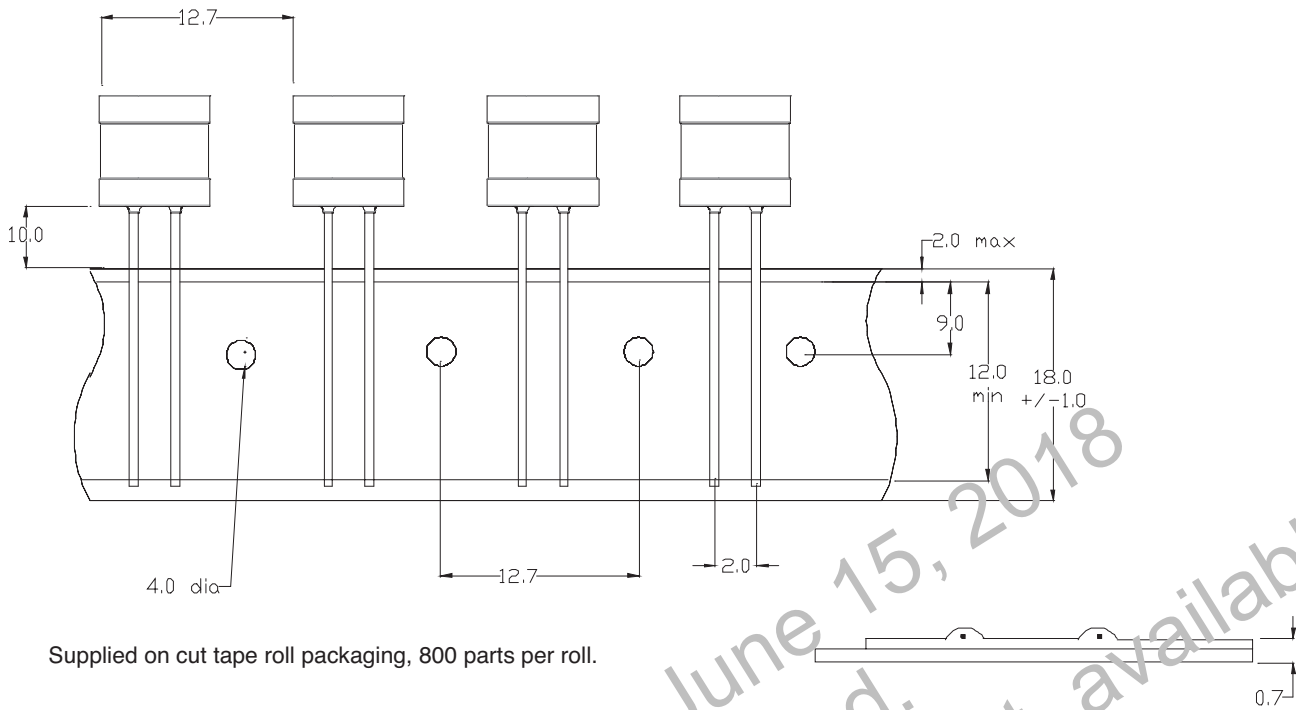

Inductance characteristics

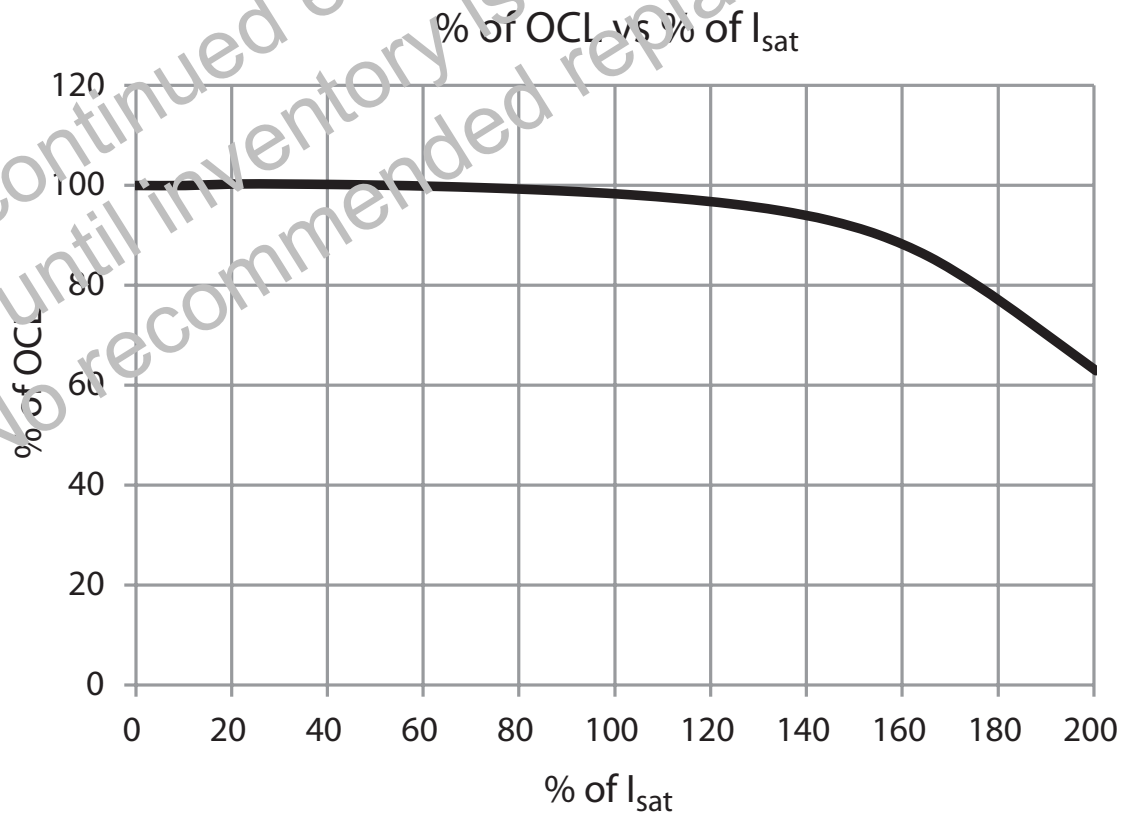

Wave solder profile

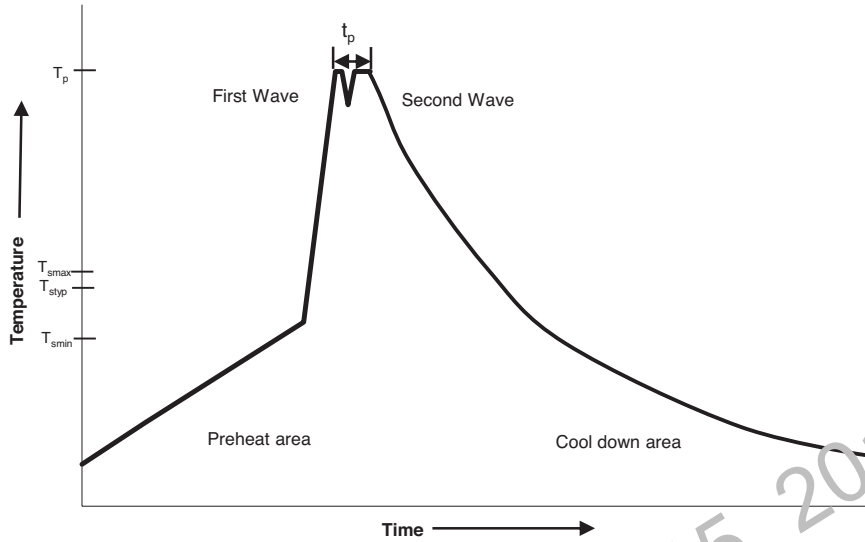

Reference EN 61760-1:2006

Profile Feature	Standard SnPb Solder	Lead (Pb) Free Solder
Preheat		
Temperature min. (T_{smin})	100°C	100°C
Temperature typ. (T_{styp})	120°C	120°C
Temperature max. (T_{smax})	130°C	130°C
Time (T_{smin} to T_{smax}) (t_s)	70 seconds	70 seconds
Δ preheat to max Temperature	150°C max.	150°C max.
Peak temperature (T_p)	230°C - 260°C	250°C - 260°C
Time at peak temperature (t_p)	10 seconds max 5 seconds max each wave	10 seconds max 5 seconds max each wave
Ramp-down rate	~ 2 K/s min ~ 3.5 K/s typ ~ 5 K/s max	~ 2 K/s min ~ 3.5 K/s typ ~ 5 K/s max
Time 25°C to 25°C	4 minutes	4 minutes

Manual solder

350°C, 4-5 seconds. (by soldering iron). Generally manual, hand soldering is not recommended.

Life Support Policy: Eaton does not authorize the use of any of its products for use in life support devices or systems without the express written approval of an officer of the Company. Life support systems are devices which support or sustain life, and whose failure to perform, when properly used in accordance with instructions for use provided in the labeling, can be reasonably expected to result in significant injury to the user.

Eaton reserves the right, without notice, to change design or construction of any products and to discontinue or limit distribution of any products. Eaton also reserves the right to change or update, without notice, any technical information contained in this bulletin.

Eaton
Electronics Division
1000 Eaton Boulevard
Cleveland, OH 44122
United States
www.eaton.com/electronics

© 2017 Eaton
All Rights Reserved
Printed in USA
Publication No. 10334 BU-SB14688
October 2017

Eaton is a registered trademark.

All other trademarks are property of their respective owners.

X-ON Electronics

Largest Supplier of Electrical and Electronic Components

Click to view similar products for [Fixed Inductors](#) category:

Click to view products by [Eaton](#) manufacturer:

Other Similar products are found below :

[CR43NP-680KC](#) [CR54NP-820KC](#) [CR54NP-8R5MC](#) [CTX32CT-100](#) [70F224AI](#) [MGDQ4-00004-P](#) [MHL1ECTTP18NJ](#) [MHL1JCTTD12NJ](#)
[PE-51506NL](#) [PE-53601NL](#) [PE-53602NL](#) [PE-53630NL](#) [PE-53824SNLT](#) [PE-92100NL](#) [PG0434.801NLT](#) [PG0936.113NLT](#) [9310-16](#) [PM06-2N7](#) [PM06-39NJ](#) [A01TK](#) [1206CS-471XJ](#) [HC2-2R2TR](#) [HC2LP-R47-R](#) [HC3-2R2-R](#) [1206CS-151XG](#) [RCH664NP-140L](#) [RCH664NP-4R7M](#)
[RCH8011NP-221L](#) [RCP1317NP-332L](#) [RCP1317NP-391L](#) [RCR1010NP-470M](#) [RCR110DNP-331L](#) [DH2280-4R7M](#) [DS1608C-106](#) [ASPI-4020HI-R10M-T](#) [B10TJ](#) [B82477P4333M](#) [B82498B3101J000](#) [B82498B3680J000](#) [ELJ-RE27NJF2](#) [1812CS-153XJ](#) [1812CS-183XJ](#) [1812CS-223XJ](#) [1812LS-104XJ](#) [1812LS-105XJ](#) [1812LS-124XJ](#) [1812LS-154XJ](#) [1812LS-223XJ](#) [1812LS-224XJ](#) [1812LS-563XJ](#)